

NORWICH TO TILBURY – EN020027

WRITTEN FOLLOW-UP SUBMISSION ON BEHALF OF THE DEDHAM VALE SOCIETY

Submitted by Richard Buxton, Richard Buxton Solicitors, Cambridge

Following the Issue Specific Hearing on 29 April 2026

Introduction

1. This submission follows the Issue Specific Hearing held on 29 April 2026, at which Richard Buxton appeared on behalf of the Dedham Vale Society, with the support of Pylons East Anglia Limited. The Examining Authority offered him the opportunity to review points raised and to follow up in writing (Action Points, item 30).
2. Although the technical background is complicated, and the Society advances what it says below with some diffidence, its concerns are straightforward. Central to these concerns is that, so far as the Society has been able to establish, National Grid has not produced to this examination a proper costing of a continuous underground HVDC cable along the actual onshore corridor from Norwich to Tilbury. The only body that has assessed that specific option, NESO, found it to be economically comparable with the overhead line proposal. National Grid disputes that finding but, so far as the Society has been able to establish, has not substituted its own analysis of that specific option.
3. While the Society is unable to resolve this point itself, it strikes it as imperative that the question be properly and transparently addressed before a decision is made on the DCO application.
4. The Society has reviewed the documents drawn to its attention by the Examining Authority – written question ALT 1.5 and National Grid’s answer to it in REP3-074; REP3-070 with National Grid’s April 2026 responses to Deadline 2 representations by

Pylons East Anglia Limited (“the April 2026 responses”); National Grid’s 2023 Strategic Options Backcheck and Review (APP-357); and National Grid’s own published documents for its Sealink and Eastern Green Link 3 and 4 projects. As set out below, the net result is that important questions remain unanswered.

5. The Society is a lay organisation has done its best to understand the technical material and to identify questions that appear to it to deserve an answer. If it is wrong, no doubt it will be easy for National Grid to explain clearly and provide the transparent analysis that would resolve any uncertainty.

The statutory duty: section 85 CROW Act 2000

6. Central to the Society’s concerns is the duty in section 85 of the Countryside and Rights of Way Act 2000, which, as amended by the Levelling-up and Regeneration 2024, provides:

“In exercising or performing any functions in relation to, or so as to affect, land in an area of outstanding natural beauty [now National Landscape] in England, a relevant authority ... must seek to further the purpose of conserving and enhancing the natural beauty of the area of outstanding natural beauty.”

7. Various points arise.
 - a) The duty is to seek to further the conservation and enhancement purpose. This is a positive obligation to advance that purpose, not merely to have regard to it. It does not prohibit development etc. which does not further, but ways of doing that development which have less impact, or a positive impact, must be considered, and if feasible adopted.
 - b) The duty must logically extend to the visual experience of the landscape, both from within it and from places from which it is visible. Thus, here the Society’s concern extends to the character of the wider project as seen from within the National Landscape.
 - c) The duty falls on the Examining Authority in making its recommendation and on the Secretary of State in making the decision. Obviously, the applicant National Grid will play a critical part in developing options for them to consider.

- d) The duty cannot be discharged by financial contribution alone, as addressed further below.
- e) NPS EN-5 at paragraph 1.1.5 reinforces the duty by providing that the network must be planned to ensure that the right kind of technology is brought online at the right time and in the right places. Here, the choice of technology directly determines the level of harm to the National Landscape.
- f) The strengthened section 85 duty came into force through the 2024 amendment after National Grid's alternatives assessment was substantially designed and conducted. National Grid's assessment of alternatives has not, so far as the society is aware, been revisited in light of this strengthened obligation.

The issue-specific hearing

- 8. The Society attended the hearing to address two connected matters: essentially, to set out the legal duty as above and based on that, why, so far as the Society can establish, the option of HVDC underground for the entire route has not been assessed as a continuous onshore option. For that would cause less harm than the HVAC solution to the National Landscape (as well, albeit less in the purview of the Society, multiple other benefits).
- 9. There is a fundamental distinction between undergrounding the section of the route through the Dedham Vale National Landscape – which National Grid does indeed propose, in the form of 400 kV HVAC cable – and the question the Society raises, which is whether the entire route should have been considered for HVDC underground installation. These are quite different things, and the Society is concerned that they may have been conflated in the examination.
- 10. When the Society began to address the second point at the hearing, the Examining Authority indicated that the matter had already been addressed and directed attention to written question ALT 1.5 and National Grid's answer in REP3-074, and by follow-up in REP3-070. The Society has now reviewed those and other materials and does not find its concerns answered.

National Grid's APP-357

11. The Society has now considered APP-357 – the 2023 Strategic Options Backcheck and Review. National Grid repeatedly relies on it in this examination as having considered “all onshore alternatives including HVDC.” The Society accepts that APP-357 considered a wide range of options. However, it does appear to be crucially lacking as to the point now raised.
12. APP-357 assesses the following onshore options for the northern section of the route (Norwich to Bramford, the EC5N boundary): four corridor variants – EAN1 to EAN4 – each considered in four technologies: AC overhead line, AC underground cable, AC gas insulated line, and HVDC underground. HVDC underground was therefore costed for the northern sections individually.
13. For the southern section (Bramford to Tilbury, the EC5/LE1 boundary), APP-357 assesses three corridor variants – EAS1, EAS2 and EAS3 – but these appear to be assessed as overhead line options only. The full-route HVDC option for the entire Norwich to Tilbury corridor is presented as “Offshore 1,” which is described as a Norwich to Tilbury connection routed offshore – subsea – not as a continuous onshore underground cable along the currently proposed corridor or similar.
14. But the latter is the option that NESO assessed and found to be cost-comparable. The Society may have misread a complex document, and if so it would welcome correction. But its reading of APP-357 is that this specific option was not assessed.
15. Further, Table B in the APP-357 executive summary presents Offshore 1 at both 4,000 MW (capital cost £2,882m) and 6,000 MW (capital cost £4,097m). At paragraph EX.61, National Grid states that the 4,000 MW option “no longer provides the required capacity” because contracted generation has grown. This is National Grid’s explanation for insisting on 6 GW. The Society notes that explanation, but the same table records the figure of £2,882m capital cost for a 4,000 MW option, which – even on the offshore routing – is materially closer to the overhead line cost than the £4,097m or £5,854m figures that are typically cited in this examination. This raises the question: what would the equivalent onshore underground option cost at 4,000 MW, and has that ever been calculated?

ALT 1.5 and ALT 1.6 do not resolve the issue

16. ALT 1.5 asked National Grid for a summary of the cost difference between HVAC and HVDC through the Dedham Vale National Landscape, and the location and scale of converter stations at each end of such a cable route. National Grid answered that specific question. It assessed the cost of a 20-kilometre HVDC underground cable through the Dedham Vale, with converter stations at each end reconnecting the cable to the AC overhead line network. It calculated that this would require six converter stations – three 2 GW stations at each end – with a combined permanent land take of some 90 hectares and a cost of £1,788.5 million for HVDC compared with £815.4 million for HVAC.
17. ALT 1.6 asked National Grid to review whether any new reasonable route alternatives or substation locations had materialised. National Grid answered that no new alternatives had been identified.
18. Those are not answers to the Society's concern. An isolated HVDC section through the Dedham Vale, with converter stations at each end of a 20-kilometre stretch is not an option that anyone has proposed. At least, the Society has not suggested it, nor has Pylons East Anglia. There are obvious costs and landscape difficulties. But the difficulties do not arise if the whole route is underground HVDC solution.
19. The answer to ALT 1.6 addresses a different question – whether alternative routes or substation locations have been considered. The Society's concern is not about a different route. It is about a different technology applied along the same one.
20. National Grid's own figures in the answer to ALT 1.5 show that an HVDC construction swathe through the Dedham Vale would be 85 metres wide, compared with 120 metres for HVAC. That is at least a 30 per cent reduction in construction corridor width, before cable ploughing – addressed further below – is considered.

Capacity baseline

21. A further question arises about what appears to be an inconsistency in National Grid's approach to the capacity required of any HVDC alternative. There may of course be a technical explanation that the Society has not understood, but as it sees it the issue is

as follows.

22. For this project, National Grid insists that any HVDC alternative must provide 6 GW of capacity, requiring three 2 GW circuits with six converter stations. That is the basis for its headline HVDC cost figures of £5.8 billion or £4.1 billion.
23. However, from National Grid's own published documents for its Eastern Green Link 3 and 4 projects, it appears that for those projects National Grid compared a 400 kV double-circuit AC overhead line – with a theoretical thermal rating of approximately 6,380 MW – against a 4 GW HVDC solution delivered by two 2 GW DC circuits. It did not, for those projects, require the HVDC option to match the AC nameplate rating.
24. National Grid's own EGL3 and EGL4 Strategic Optioneering Report appears to explain why. It states: *"Power flows on AC transmission system circuits cannot be controlled to the same extent as can be achieved using HVDC connections. This lower level of controllability can result in higher power flows particularly during transmission system fault conditions. Taking account of the potential for higher power flows ... the AC option would need to consist of a high capacity (6,930 MW) double circuit route to meet any high loading during fault conditions."* In other words, the 6 GW AC rating appears to include a substantial contingency margin that does not arise in the same way for HVDC, because HVDC power flows are controllable.
25. If that is correct, then comparing 6 GW AC with 6 GW HVDC may not be comparing like with like. National Grid accepted 4 GW as the functional HVDC equivalent for EGL3 and EGL4. The Society's question is simply this: why is 6 GW required for Norwich to Tilbury when 4 GW was accepted as equivalent for those projects, and what would a 4 GW onshore underground HVDC solution for this corridor cost?
26. The Society notes that APP-357 itself provides a 4,000 MW figure for Offshore 1 at £2,882m capital cost. National Grid dismisses this on the basis that contracted generation has grown beyond 4,000 MW. The Society is not able to challenge that technical assessment. But it does raise the question of whether the same controllability argument that led National Grid to accept 4 GW for EGL3 and EGL4 applies equally here, and whether that has ever been transparently addressed in this examination. It is important that this be precisely clarified.

National Grid's assessment of overhead line harms in other projects

27. National Grid's Strategic Options Backcheck Report for the Sealink project assessed the potential harms of an overhead line option and identified, among other things, the potential for permanent adverse visual effects, proximity to settlements, and impacts on agricultural land. Based on that assessment – and because an economically viable offshore alternative existed – overhead lines were rejected for Sealink.
28. The Society is struck by the contrast between the framework National Grid applied when assessing overhead line harms for Sealink – a framework that led it to reject overhead lines – and the approach taken here. To reassure on the point, the Society suggests that National Grid should explain the difference in approach.
29. Similarly, National Grid's June 2024 consultation document for EGL3 and EGL4 identified advantages for HVDC over AC overhead line: comparable capital costs but materially lower lifetime costs; greater power flow controllability; lower delivery risk over long route lengths; and a conclusion that overhead lines could not be consented and constructed within the required timescale. The Society is aware that National Grid has given reasons why some of those conclusions do not apply to Norwich to Tilbury. But it notes that National Grid's own analysis in other projects identifies technical, environmental and deliverability advantages for HVDC over overhead line that are, at best, only partially acknowledged in its analysis for this project. Again, this warrants fuller explanation.

NESO report

30. The 2024 National Energy System Operator East Anglia Network Study assessed a fully underground HVDC cable for the whole Norwich to Tilbury route and found it to be economically comparable with, and in some scenarios lower cost than, the proposed overhead line option when assessed on aligned delivery assumptions. That finding has not, so far as the Society is aware, been withdrawn or revised.
31. National Grid has disputed the NESO methodology in general terms in its response "2024 National Grid Electricity Transmission Response to the ESO East Anglia Network Study (March 2024) April 2024". But what it has not done, so far as the Society can see, is properly engage with its findings at least relevantly to the issue here. Similarly

National Grid's April 2026 responses in REP-070 do not address the NESO study's whole-route onshore assessment. National Grid's general objections to HVDC – cost, supply chain, technical complexity – must have been available to NESO when it conducted its study.

32. Overall, the question is properly asked: whether National Grid has produced, anywhere in this examination, a transparent substitute analysis of the specific option that NESO assessed, namely a continuous onshore underground HVDC cable along the full 184-kilometre corridor.
33. Further and in any event National Grid's own cost comparisons do not appear to have quantified the socio-economic and natural capital impacts of the overhead line option on a basis consistent with the alternatives. Those impacts – effects on the National Landscape, on amenity, on agricultural land, on property values and on community wellbeing – are plainly higher for overhead lines than for underground HVDC. The Society cannot itself quantify them; but surely, they should be. Leaving them unquantified risks the options comparison being conducted on an uneven basis, and that the Treasury Green Book, reflecting good practice in public-sector options appraisal, would require that. National Grid's position, as stated in the REP-070 April 2026 responses, is that the Green Book does not apply to it. The Society reserves its position on that and supports the detailed submissions of Pylons East Anglia on the point.

The East Anglia Connection Node

34. National Grid's HVDC cost calculations include infrastructure associated with the East Anglia Connection Node near Ardreigh. The EACN's location and concept are themselves controversial. The Society's understanding is that National Grid decided, at an early stage, to locate the EACN on the Tendring Peninsula, and that this decision effectively embedded certain National Landscape impacts into the project from the outset.
35. For now, the Society submits that any EACN should not be treated as a fixed and immovable constraint when costing HVDC alternatives. If a whole-route onshore HVDC option were to be properly assessed, that assessment should be conducted both

with and without the EACN as a fixed intermediate connection point, so that the Examining Authority can understand the true cost of each scenario.

Cable ploughing

36. National Grid's cost comparisons for underground installation throughout this examination appear to assume conventional open-cut trenching. It understands that the technique of "cable ploughing", can instal underground cables in a narrow slit rather than an open trench, and is said to achieve a construction working width of under 10 metres compared to the 65 or 85-metre corridors assumed in National Grid's underground costings.
37. The Society understands that specialist contractor ATP carried out what it describes as the first use of cable ploughing for 400 kV AC undergrounding in the United Kingdom at Hirwaun in Wales in April 2024, and that this methodology was accepted by National Grid. This demonstration predates National Grid's DCO submission in August 2025. Please see ATP information provided with this.
38. The Institution of Engineering and Technology's 2025 update to its 2012 cost study – on which National Grid's comparative cost figures rest – acknowledged that cable ploughing had not been considered in the 2012 study and called for further work to establish its feasibility and cost.
39. The Society does not know whether cable ploughing would be technically feasible or cost-effective for all or any part of this route. It is not itself able to assess that. But the technique appears to be wholly absent from National Grid's cost comparisons, and that the IET itself has acknowledged the gap. It raises a question that surely needs an answer.

Financial contributions and the Section 85 duty

40. Following the Society's submissions at the hearing, proposed financial contribution to the Dedham Vale National Landscape Partnership were mentioned. Thus, it is said, the section 85 duty can be discharged in that way. The Society notes that the National Landscape Manager indicated that heads of terms are being negotiated and progressing well.

41. While it does not criticise the Partnership for engaging constructively with National Grid, this approach is troubling. The mitigation hierarchy – avoid, mitigate, compensate, in that order of preference – is well established in environmental law and planning policy. Compensation, on that understanding, is appropriate only where avoidance and mitigation have been fully and genuinely considered and found not to be feasible. A financial contribution to the Partnership is, by its nature, compensatory: it funds activities elsewhere in the landscape but does not restore, undo or avoid the harm of the pylons, the cable swathe or the permanent vegetation clearance corridor within and visible from the National Landscape.
42. The Society's concern is that if the prior questions of better avoidance/mitigation are feasible then a financial contribution at the compensation stage cannot make good that gap. The Examining Authority is respectfully requested to consider carefully here whether the avoidance and mitigation stages have been properly addressed here.
43. The Lower Thames Crossing decision has been suggested as authority for the proposition that a financial contribution can meet the section 85 duty. The Society does not suggest that financial contributions can never be appropriate, but issues of avoidance and mitigation come first for consideration.

What the Society asks

44. The Society does not of course ask the Examining Authority on the basis of these submissions to conclude that whole-route HVDC undergrounding must be the way forward. But it does raise what are submitted to be valid questions in relation to its apparently not being considered. It asks that the questions it has raised be addressed transparently and in full before any recommendation is made. It would be grateful if National Grid were required to provide:
- (a) A clear explanation of the scope of the HVDC assessment in APP-357, addressing specifically whether a continuous onshore underground HVDC cable along the full 184 km Norwich to Tilbury corridor was costed as a standalone option, and if not, why not. If it was not, a costing of that option, both with and without the EACN as a fixed intermediate connection point.
- (b) An explanation of why the HVDC capacity baseline for Norwich to Tilbury is 6 GW

rather than 4 GW, having regard to the fact that National Grid used 4 GW HVDC as the functional equivalent of a 400 kV AC double circuit in its EGL3 and EGL4 options appraisal, and a costing of a 4 GW (two-circuit) HVDC solution for the full onshore corridor if the explanation is not accepted.

- (c) A full, substantive response to the NESO East Anglia Network Study 2024, and its finding that whole-route underground HVDC is cost-comparable with the proposed overhead line on a consistent delivery baseline, either accepting that finding or producing National Grid's own substitute analysis of the specific onshore corridor option and explaining precisely where and why the NESO assessment is said to be wrong.
- (d) An explanation of why cable ploughing technology has not been considered in National Grid's underground installation cost assessments, having regard to the ATP evidence in the Examination Library and the IET's 2025 acknowledgement that cable ploughing was not considered in its 2012 cost study. In any event, to include same in any reassessment.
- (e) A demonstration that the socio-economic and natural capital impacts of the overhead line option have been assessed on a basis consistent with those of the alternatives, with those impacts quantified to the extent possible.
- (f) A clear statement of how the section 85 duty in its strengthened 2024 form has been actively furthered in the design of the project, demonstrating that avoidance and mitigation were genuinely considered and found infeasible before compensation by financial contribution was adopted, and as above in relation to the use of HVDC underground.

Conclusion

45. The Society is of course not an engineering body, but it cannot identify, in APP-357 or anywhere else in this examination, a transparent costing of a continuous onshore underground HVDC cable along the full length of the proposed route. It finds itself unable to understand why National Grid insists on 6 GW as the HVDC capacity equivalent when it accepted 4 GW for comparable projects. It finds that the NESO study's finding that whole-route onshore HVDC is cost-comparable has been disputed

but not, so far as it can tell, answered with a substitute analysis. Given the provenance of that, it is extraordinary that the point is not dealt with clearly or at all. And it finds that cable ploughing – a technology acknowledged by the IET itself to have been absent from its cost study – has not been addressed.

46. The Society therefore respectfully invites the Examining Authority to share its concerns with National Grid, and to require those answers to be provided before a recommendation is made on a project whose effects will endure for many decades.

47. Specifically in relation to the Dedham Vale, the Society submits it is entitled to, a rigorous and complete assessment of whether the harm proposed to be done to it and to the wider corridor was genuinely unavoidable. On the Society's reading of the evidence, that assessment has not yet been made.



Cambridge

On behalf of the Dedham Vale Society

11 May 2026

Accompanying papers: It is unclear what papers the Examining Authority has. The PINS index does not list the NESO or IET papers, but it must have them. For the avoidance of doubt we are uploading these, separately:

- Section 85 Countryside and Rights of Way Act 2000
- The NESO paper as above "National Energy System Operator East Anglia Network Study, Match 2024"
- The IET paper as above "Institution of Engineering and Technology with Mott MacDonald: A Comparison of Electricity Transmission Technologies: Costs and Characteristics – April 2025 update to 2012 study"
- "ATP Cable Plough – Cable Ploughing submissions summary paper" – September 2024 (following demonstration in April 2024)

Artificial intelligence: this submission has involved instructions from clients and own reading, but with assistance from AI in helping frame and cross-check content.

Section 85 Countryside and Rights of Way Act 2000



Countryside and Rights of Way Act 2000

2000 CHAPTER 37

PART IV

AREAS OF OUTSTANDING NATURAL BEAUTY

85 General duty of public bodies etc.

[^{F1}(A1) In exercising or performing any functions in relation to, or so as to affect, land in an area of outstanding natural beauty in England, a relevant authority other than a devolved Welsh authority must seek to further the purpose of conserving and enhancing the natural beauty of the area of outstanding natural beauty.

(A2) In exercising or performing any functions in relation to, or so as to affect, land in an area of outstanding natural beauty in England, a devolved Welsh authority must have regard to the purpose of conserving and enhancing the natural beauty of the area of outstanding natural beauty.]

(1) In exercising or performing any functions in relation to, or so as to affect, land in an area of outstanding natural beauty [^{F2}in Wales], a relevant authority shall have regard to the purpose of conserving and enhancing the natural beauty of the area of outstanding natural beauty.

[^{F3}(1A) The Secretary of State may by regulations make provision about how a relevant authority is to comply with the duty under subsection (A1) (including provision about things that the authority may, must or must not do to comply with the duty).]

(2) The following are relevant authorities for the purposes of this section—

- (a) any Minister of the Crown,
- (b) any public body,
- (c) any statutory undertaker,
- (d) any person holding public office.

(3) In subsection (2)—

[^{F4}“devolved Welsh authority” has the same meaning as in the Government of Wales Act 2006 (see, in particular, section 157A of that Act);]

Changes to legislation: Countryside and Rights of Way Act 2000, Section 85 is up to date with all changes known to be in force on or before 23 March 2026. There are changes that may be brought into force at a future date. Changes that have been made appear in the content and are referenced with annotations. (See end of Document for details) View outstanding changes

- “public body” includes
- (a) a county council, county borough council, district council, parish council or community council;
 - (b) a joint planning board within the meaning of section 2 of the ^{M1}Town and Country Planning Act 1990;
 - (c) a joint committee appointed under section 102(1)(b) of the ^{M2}Local Government Act 1972;
 - (d) ^{F5}...
 - (e) [^{F6}a corporate joint committee established by regulations made under Part 5 of the Local Government and Elections (Wales) Act 2021;]
- “public office” means—
- (a) an office under Her Majesty;
 - (b) an office created or continued in existence by a public general Act; or
 - (c) an office the remuneration in respect of which is paid out of money provided by Parliament
- [^{F7}“statutory undertaker” means a person—
- (a) who is or is deemed to be a statutory undertaker for the purposes of Part 11 of the Town and Country Planning Act 1990, or
 - (b) who holds a gas system planner licence under section 7AA of the Gas Act 1986.]

Textual Amendments

- F1** S. 85(A1)(A2) inserted (26.12.2023) by [Levelling-up and Regeneration Act 2023 \(c. 55\)](#), **ss. 245(6)(a), 255(9)(b)** (with s. 247)
- F2** Words in s. 85(1) inserted (26.12.2023) by [Levelling-up and Regeneration Act 2023 \(c. 55\)](#), **ss. 245(6)(b), 255(9)(b)** (with s. 247)
- F3** S. 85(1A) inserted (26.12.2023) by [Levelling-up and Regeneration Act 2023 \(c. 55\)](#), **ss. 245(6)(c), 255(9)(b)** (with s. 247)
- F4** Words in s. 85(3) inserted (26.12.2023) by [Levelling-up and Regeneration Act 2023 \(c. 55\)](#), **ss. 245(6)(d), 255(9)(b)** (with s. 247)
- F5** Words in s. 85(3) omitted (21.1.2021) by virtue of [Local Government and Elections \(Wales\) Act 2021 \(asc 1\)](#), s. 175(1)(e), **Sch. 9 para. 37**
- F6** Words in s. 85(3) inserted (3.12.2021) by [The Countryside and Rights of Way Act 2000 \(Meaning of Public Body\) \(Wales\) Regulations 2021 \(S.I. 2021/1355\)](#), regs. 1(2), **2**
- F7** Words in s. 85(3) substituted (1.10.2024) by [The Energy Act 2023 \(Consequential Amendments\) Regulations 2024 \(S.I. 2024/706\)](#), regs. 1(1), **15**; S.I. 2024/957, reg. 2(a)

Commencement Information

- I1** Pt. 4 (ss. 82-93) wholly in force at 1.5.2001; Pt. 4 not in force at Royal Assent see s. 103(3); Pt. 4 in force for E. at 1.4.2001 by [S.I. 2001/114](#), **art. 2(2)(e)**; Pt. 4 in force for W. at 1.5.2001 by [S.I. 2001/1410](#), **art. 2(g)**

Marginal Citations

- M1** 1990 c. 8.
- M2** 1972 c. 70.

Changes to legislation:

Countryside and Rights of Way Act 2000, Section 85 is up to date with all changes known to be in force on or before 23 March 2026. There are changes that may be brought into force at a future date. Changes that have been made appear in the content and are referenced with annotations.

[View outstanding changes](#)

Changes and effects yet to be applied to :

- s. 55A inserted by [2015 c. 20 s. 20](#)
- s. 56A inserted by [2015 c. 20 s. 21](#)
- s. 56B inserted by [2015 c. 20 s. 22\(1\)](#)

Changes and effects yet to be applied to the whole Act associated Parts and Chapters:

Whole provisions yet to be inserted into this Act (including any effects on those provisions):

- s. 55A inserted by [2015 c. 20 s. 20](#)
- s. 56A inserted by [2015 c. 20 s. 21](#)
- s. 56B inserted by [2015 c. 20 s. 22\(1\)](#)

NESO paper

ESO East Anglia Network Study

March 2024

Context	4
1. Introduction	5
Who is the Electricity System Operator?	5
What is the electricity transmission system?	5
Electricity transmission network planning process	6
How the electricity network planning process is evolving	7
How the grid connection process works	8
2. Proposed regional energy generation and transmission network	8
Context today	8
Proposed offshore energy generation connecting into East Anglia	9
Solutions to network capacity constraints caused by increased energy generation	11
Network reinforcements currently proposed	11
Economic needs case for Bramford to Twinstead	13
3. Study Introduction	14
Exploration of voluntary offshore coordination off the coast of East Anglia	14
Offshore Coordination Support Scheme outcome	14
Rationale for the Electricity System Operator’s (ESO’s) East Anglia network study	15
Study Scope - What have we assessed?	15
4. Network technology capability assessment	16
Electricity network technologies used regularly in Great Britain	16
5. Preliminary assessment of proposed options	20
Preliminary assessment process	20
6. Holistic Assessment	21
Methodology for holistic assessment	21
Additional assessment - community sentiment	22
Options under holistic assessment	22
Assumptions relating to grid connections, network requirements and delivery dates for options under holistic assessment	23
Options Assessment	26
1. Predominately offshore option – variation without EACN	26
2. Predominately offshore option – variation with EACN	28
3. Onshore option	31
4. Alternative onshore option – variation without Bramford to EACN	33
5. Alternative onshore option – variation without EACN and option 5b sensitivity	35
6. Hybrid onshore and offshore option	37

ESO

7.	Hybrid onshore and offshore option – variation without EACN	40
8.	An onshore HVDC route.....	42
9.	Predominantly offshore option – utilising Bradwell as a landing point	45
7.	Summary of results	48
	Community sentiment	48
	Conclusions	49
	Next steps.....	50

Context

Great Britain's energy system is undergoing a generational transition. The electricity grid is critical in supporting this transition and ensuring the delivery of a reliable supply of energy to homes and businesses across Great Britain.

East Anglia is playing a vital role in this transition with a significant increase in low carbon and renewable generation, predominantly from offshore wind, interconnection and nuclear generation. In many ways, East Anglia is at a more advanced stage of its energy transition than other regions due to early seabed leasing rounds by The Crown Estate. As a result, many offshore wind farms off the East Anglian coast are either already generating or are due to connect before 2030. Due to these developments, the UK Government incentivised voluntary coordination of this offshore infrastructure through what is known as the Offshore Coordinated Support Scheme (OCSS).

As announced by the Department for Energy Security and Net Zero on 5 December 2023, three projects within this scheme: North Falls Offshore Wind Farm, Five Estuaries Offshore Wind Farm along with National Grid Electricity Transmission (NGET (Sea Link)), have proposed a coordinated network design which sees the coordination of the two offshore wind farms and Sea Link. These developers are currently exploring the feasibility of this proposal and the UK Government will shortly be deciding whether to continue funding this exploration¹.

Recognising that coordinating the connections of these two offshore wind farms may change underlying power flows in East Anglia, we, the Electricity System Operator (ESO), committed to independently assess different network configuration options that could transfer power around and across the region. For the purposes of this study, the coordination being proposed by developers via the OCSS has been used as the baseline.

This report presents ten network configuration options that transfer power around or across the region in different ways. Six of these were developed through collaboration with NGET and four of them have been proposed by community representatives.

For this study, we have utilised the same criteria as within the Holistic Network Design (HND). Requested by stakeholders, we have also stress tested these options against a range of other time-based and scenario sensitivities. The options have also been benchmarked against comparable projects within Britain and Europe.

During our three-month study period the invaluable feedback we have received is reflected where possible in the assessment below. While the assessment itself does not recommend an optimal path to take, the results show that there is no universally accepted solution that delivers the required electricity network capacity needed by the early 2030s.

Each option comes with trade-offs between costs borne on energy consumers, communities hosting this nationally significant infrastructure as well as environmental considerations. We hope that this assessment will provide stakeholders with an independent view of different on and offshore circuit options as well as currently available network infrastructure technology within Great Britain.

¹ This funding has been allocated through the Offshore Coordinated Support Scheme, known as OCSS.

1. Introduction

Who is the Electricity System Operator?

As the Electricity System Operator (ESO) for Great Britain, our role is to operate Great Britain's electricity transmission system, while developing a secure, clean, and fair system for tomorrow. We transport electricity around the system to ensure electricity supply to matches demand second-by-second, 365 days a year.

We work in partnership with the Government, Devolved Governments and regional authorities, the energy regulator (Office of Gas and Electricity Markets (Ofgem)), industry and consumers to guide Great Britain on the energy resources, markets and networks required to securely accelerate the transition away from fossil fuels into new energy technologies and economies.

As the ESO, we do not generate or sell electricity, we also do not own or build the infrastructure the electricity travels through. This ensures the ESO is independent of companies with a commercial interest in generating energy or building network infrastructure.

In April 2019, the ESO, then part of National Grid became a legally separate business within the National Grid PLC group. This means that the ESO is independent from the Transmission Owners, including National Grid Electricity Transmission (NGET). This separation was to provide greater transparency in our decision making and confidence in our independence.

With the passing of the Energy Act 2023, we are transitioning into an independent public corporation named National Energy System Operator (NESO) in the summer of 2024. We will have new responsibilities for advising government across the whole energy system as it transitions to net zero, from strategic network planning across electricity and gas to new technologies such as hydrogen.

What is the electricity transmission system?

The electricity transmission network is often compared to Great Britain's motorways. It transports high voltage electricity, ensuring cities and towns are connected and supplied with electricity. This high voltage electricity is then moved through distribution networks, equivalent to the A and B roads, and turned into a lower voltage for homes and businesses to use every day.

The network spans across Great Britain and comprises a mixture of overhead cables, underground cabling and subsea cables – these assets can operate at a range of voltages such as 400 kV, 275 kV and 132 kV.

These are all linked together via substations across Great Britain to connect generators, interconnectors, large demand (such as transport links and factories), and distribution systems (that provide electricity to homes and small businesses). Distribution networks carry electricity at 132 kV and below in England and Wales, and 66 kV and below in Scotland.



400 kV or 400,000 volts is roughly 2000 times the voltage of the electricity outlets in our homes. High voltages are very effective for transmitting electricity over long distances.



As the ESO, we are responsible for operating the transmission networks in England, Wales, Scotland and in the surrounding offshore waters, ensuring that electricity is transported from where it is generated to where it is needed reliably, efficiently and economically.

Great Britain has three onshore Transmission Owners that own, maintain and develop their networks, namely National Grid Electricity Transmission (NGET), Scottish Power Energy Networks (SPEN) and Scottish and Southern Energy Networks Transmission (SSEN). The map below illustrates their boundaries. There are also several offshore developers that own the assets that connect operational offshore wind farms to the transmission or distribution network.

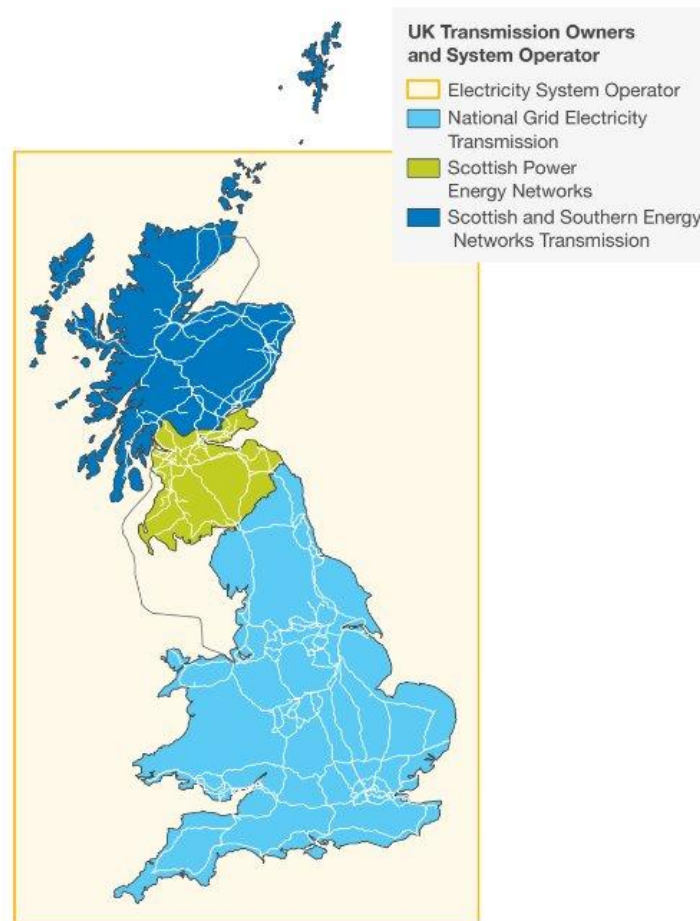

Figure 1: Map of UK Transmission Owners and System Operator

Electricity transmission network planning process

One of our key responsibilities is to model Great Britain's future energy supply and demand needs and put forward recommendations for a high-level coordinated electricity network to meet those needs in a safe, efficient and affordable way.

The process involves assessing a range of different network and non-network build options to ensure electricity can get to where it is needed, when it is needed, and we work in close collaboration with the Transmission Owners throughout this process.

Our role is to stress test network options provided to us, primarily by the Transmission Owners, against a range of different future energy scenarios and ensure that any proposed new network infrastructure is balanced against agreed design criteria. The four criteria we use for this assessment is below:





Objective	Description
 Economic and efficient costs	The network design should be economic and efficient, ensuring best value for bill payers
 Deliverability and operability	The network design should be deliverable, and the resulting system should be safe, reliable and operable
 Environmental impact	Environmental impacts should be avoided, minimised or mitigated by the network design, and best practice environmental management incorporated in the network design
 Local community impact	Local community impacts should be avoided, minimised, or mitigated by the network design

Table 1: Four Design Objectives

After we have put forward a coordinated network design recommendation, these designs are then used as an investment needs case by the Transmission Owners to take forward to the next stage of development to optimise further, refine and build.

It is the responsibility of the Transmission Owners to decide upon potential route corridors as well as decisions on types of infrastructure to use, and crucially consulting with local communities and planning authorities on these proposals.

This East Anglia Network Study is not part of the usual electricity transmission network planning process. It is a standalone study to assess different ways to transfer power around and across the region. This is as a result of the change in power flows from the voluntary offshore coordination being explored by National Grid Electricity Transmission (NGET (Sea Link)) North Falls Offshore Wind Farm and Five Estuaries Offshore Wind Farm. NGET have committed to carefully considering the study’s findings.

How the electricity network planning process is evolving

To ensure the network can accommodate new types of energy technologies, along with the UK Government and the regulator, we have been evolving the way electricity networks are designed.

Previously, assets generating electricity offshore were assessed on an individual basis. Each connection application was assessed through an economic lens, with consideration of the surrounding environment and network reinforcements required by the developer and Transmission Owners. Up until 2022, onshore network reinforcements, through the ESO’s *Network Option Assessment*², were also assessed through this economic lens.

More recently, we have moved to an approach where the electricity network is designed holistically from the very first step in the cycle, considering the impact of multiple connections in a coordinated way, and balancing different network options against the four design criteria mentioned previously.

This evolution began with the UK Government asking us to create a coordinated network design that connected 23 GW of offshore wind to the onshore electricity network, supporting the Government ambition of connecting 50 GW of offshore wind by 2030 (known as the *Pathway to 2030 – Holistic Network Design*)³. In

² <https://www.nationalgrideso.com/research-and-publications/network-options-assessment-noa>

³ <https://www.nationalgrideso.com/future-energy/pathway-2030-holistic-network-design>

The terms of reference for the Holistic Network Design and its subsequent follow up exercises were set by the UK Government, with alternative workstreams developed by the UK Government for offshore generation deemed too later stage to be included within the HND.

March 2024, we will publish the *Transitional Centralised Strategic Network Plan* which will facilitate connection of a further 21 GW of offshore wind connection in Scotland and provide a network plan out into the 2030s.

When the ESO transitions into a new public corporation in the summer of 2024, we will be responsible for producing a Centralised Strategic Network Plan (CSNP) as well as working with government to deliver a Strategic Spatial Energy Plan (SSEP), as announced in the UK Government's *Transmission Acceleration Action Plan (TAAP)*⁴. We expect the ESO to be commissioned to undertake the SSEP in 2024.

In practice this means working closely with UK, Scottish and Welsh governments as well as regional representatives to recommend where future electricity supply and large-scale demand should be located, and then subsequently and proactively identifying and designing energy networks (across electricity, gas and hydrogen) to ensure future iterations of the network is planned holistically, onshore, offshore and across vectors.

How the grid connection process works

We, as the ESO have overall responsibility for the electricity grid transmission connections process. This process, while under reform, is a regulatory approved process.

While in the future, we may be able to recommend to government through the strategic energy planning processes where future energy generation and demand should be regionally located, for existing grid connection contracts, we have very limited powers to move a customer's grid connection location and could be subject to legal challenge if we were to look to unilaterally alter or disregard contractual agreements.

Offshore generation previously went through what is known as Connections and Infrastructure Options Note (CION)⁵ process. This is where a developer applied to the ESO with a preference on where they would like to connect into the system. The Transmission Owners then put forward a range of options on where the developer could connect into the Transmission System based usually on their preferred location. These options were then considered by the ESO, Transmission Owner and developer and then the ESO conducted a cost benefit analysis (CBA) on these options and a collective decision was made trilaterally on where the developer should connect in, and the connection offer made on that basis.

Usually, securing a grid connection is one of the first steps that developers take in their project, owing to the length of time it takes to connect into the system. Following this, developers usually start to engage with regional stakeholders through planning and consenting processes. It is ultimately a decision for the Planning Inspectorate and the Secretary of State as to whether associated energy infrastructure is granted planning consent.

2. Proposed regional energy generation and transmission network

Context today

East Anglia has a diverse mix of electricity generation sources including offshore wind, onshore wind, nuclear, solar, storage, and gas-fired power, which currently generates approximately 5.67 GW for the area. In terms of electricity demand, East Anglia has a growing population and economy, which has led to an increase in overall energy consumption. Current peak demand for the region is approximately 1.31 GW. The existing network in the East Anglia region can currently export around 4.2 GW of electricity generation. Figure 2 shows maps of existing transmission network within the region, showing what is known as the EC5 boundary.

⁴ [Electricity networks: transmission acceleration action plan - GOV.UK \(www.gov.uk\)](https://www.gov.uk/government/uploads/system/uploads/attachment_data/file/118111/electricity-networks-transmission-acceleration-action-plan.pdf)

⁵ CION is developed by parties under the CUSC connections process and under CUSC (and more generally under s105 of the utility act). The outputs are confidentiality. Any disclosure would therefore require the other parties to the CION to consent to this.

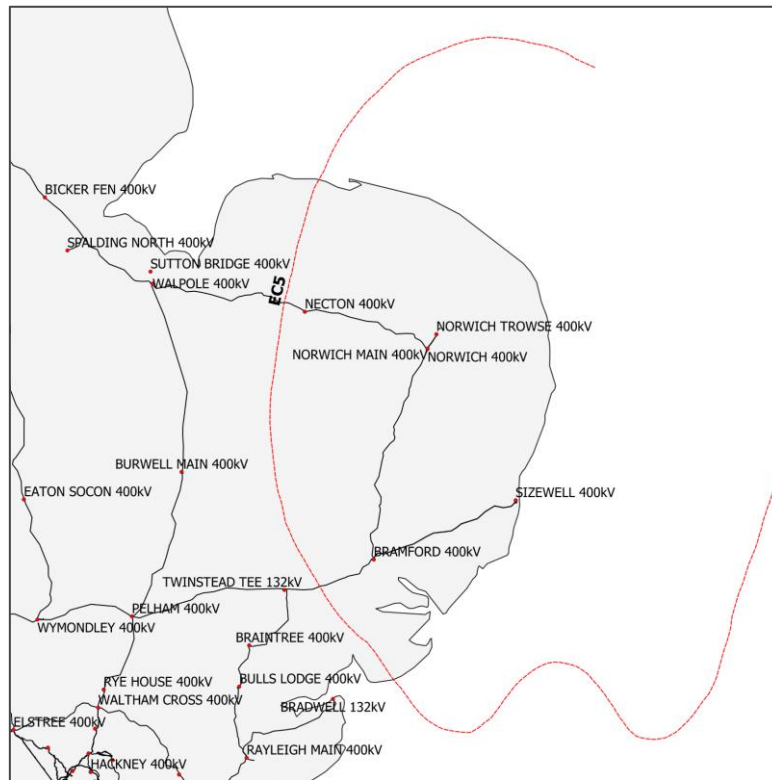

Figure 2: Map of existing transmission network in the region, showing the EC5 boundary

Boundaries such as the EC5 that includes much of East Anglia are used in our modelling to represent limitations of the existing power-flow system, as only a certain amount of power can flow out of the region based on the capacity of the existing network. As generation continues to increase within East Anglia and the behind the EC5 boundary, more export capacity from the region is required.

Proposed offshore energy generation connecting into East Anglia

Over the next decade, we will see a large growth in low-carbon renewable generation, in particular offshore wind, connecting into the East Anglia region. By 2030 we expect between 12.3 GW and 16.1 GW of new generation and interconnection into the region. As set out in *the Electricity Ten Year Statement*⁶ (ETYS). These are predominantly connecting behind the EC5 boundary which includes most of East Anglia. We first identified the need for this growth in export capacity in the NOA 2020/21 in January 2021.

Both the table and map below set out offshore generation projects planning to connect into the area⁷:

⁶ <https://www.nationalgrideso.com/research-and-publications/electricity-ten-year-statement-etys>

⁷ Information extracted from the ESO's TEC Register.

Project Name	Proposed onshore substation	Total capacity (MW)	Connection date	Generation type
Lion Link (Euro Link)	Friston 400 kV Substation	1600	2024	Interconnector
Vanguard	Necton 400 kV Substation	1320	2025	Wind Offshore
East Anglia Two	Friston 400 kV Substation	860	2025	Wind Offshore
East Anglia One North	Friston 400 kV Substation	860	2026	Wind Offshore
East Anglia Three	Bramford 400 kV Substation	Phased to total (1300)	Phased 2026-2028	Wind Offshore
Hornsea Power Station 3	Norwich Main 400 kV Substation	Phased to total (3000)	Phased 2026 - 2028	Wind Offshore
Nautilus	Friston 400 kV Substation <i>(exploring Isle of Grain as well)</i>	1500	2027	Interconnector
Vanguard East	Necton 400 kV Substation	Phased to total (1320)	Phase 2028 - 2030	Wind Offshore
Norfolk Boreas	Necton 400 kV Substation	Phased to total 1320	Phased 2029-2030	Wind Offshore
Scira-Dudgeon Extension	Norwich Main 400 kV Substation	Phased to total (1350)	Phased 2029 - 2034	Wind Offshore
Five Estuaries	East Anglia Connection Node	1080	2030	Wind Offshore
North Falls	East Anglia Connection Node	1000	2030	Wind Offshore
Race Bank Extension	Walpole 400 kV Substation	565	2030	Wind Offshore
Tarchon	East Anglia Connection Node	1400	2030	Interconnector

Table 2: offshore generation with a connection contract to the onshore electricity system within East Anglia.

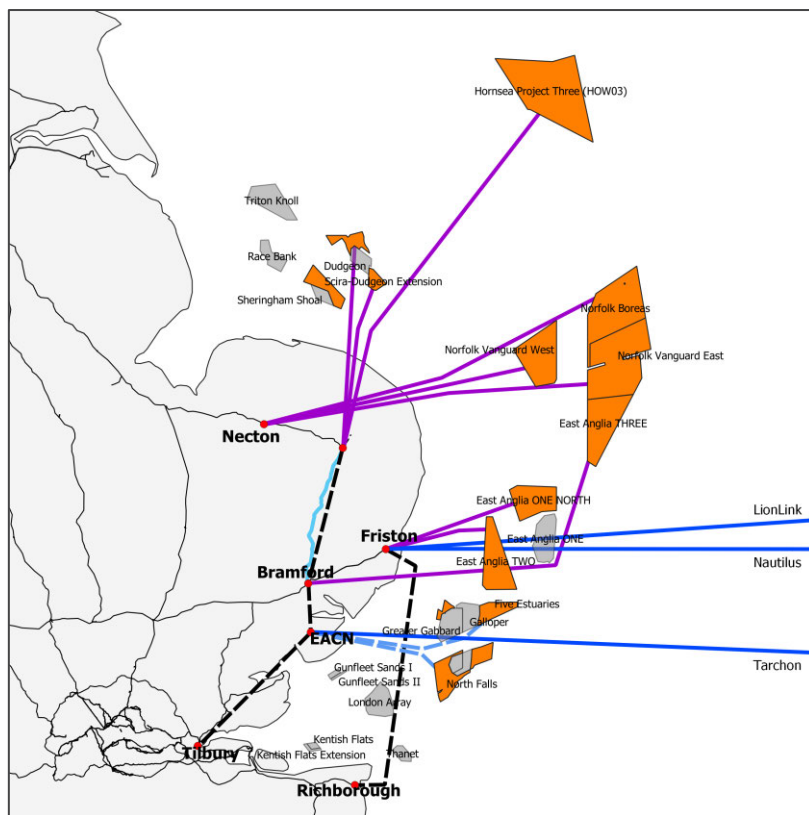

Figure 3: Map of existing and future generation in the region. Future, interconnectors are shown in dark blue. Links from future offshore windfarms are shown in purple. The light blue is the default connection arrangement for North Falls and Five Estuaries before OCSS

Our future energy scenarios are not predicting the level of regional electricity demand to increase at the same rate, meaning the region will be a net exporter of electricity. This imbalance of what is generated in the region to what is used locally means that more power will need to be transferred out of the region to the Midlands, London and the Southeast.

When there is not enough network capacity to transport power to where it is needed, bottlenecks or traffic jams (“constraints”) are created on the electricity network. Because of these bottlenecks, as the system operator, we sometimes have to pay wind farms to switch off to prevent the grid becoming overloaded – wasting cheap, sustainable home-grown wind power. We do this through the Balancing Mechanism.

Solutions to network capacity constraints caused by increased energy generation

Today there are several solutions available to us to manage the increased power flows from the region predicted for the future, these include technical solutions, additional network capacity and in the future recommending where additional generation and demand should be located.

To resolve capacity issues in the short term, we have designed the Constraint Management Intertrip service (CMIS) and Local Constraint Market⁸. Once operational, this will contract with generators in the region to provide a more economical method of managing constraints than actions through the Balancing Mechanism. This follows the success of the CMIS now in operation across the boundary between England and Scotland. These schemes will provide some short-term relief on the constraint costs, but the volume of generation and benefits that these market solutions bring are not sufficient to avoid network investment.

Different types of energy generation proposed within the region can also be a solution to network capacity constraints. As there is a large amount of weather-dependent generation already connected or due to connect in the region, interconnectors provide opportunities to export energy away from the region to other countries when it is windy, negating the need for additional network capacity to transport all the electricity generation to centres of demand within England.

Network reinforcements currently proposed

To address the forecast network capacity constraints within the region, there are several proposed electricity transmission network routes currently being brought through planning and consenting by National Grid Electricity Transmission (NGET) in this region to support the wider electricity system, these are:

⁸ [Local Constraint Market | ESO \(nationalgrideso.com\)](https://www.nationalgrideso.com)

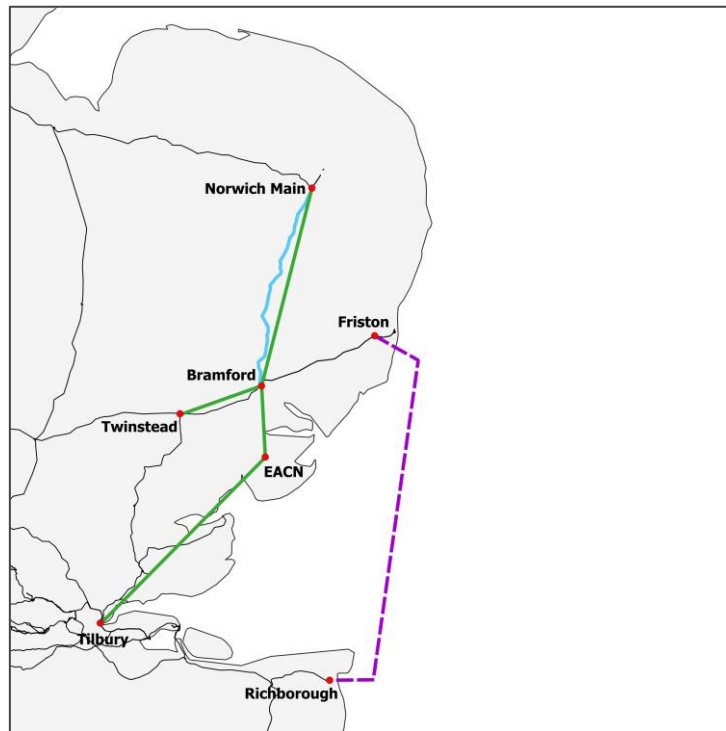

Figure 4: Map showing current reinforcements proposed by the Transmission Owner

Figure 4 Legend:

- **Works under construction** by NGET. Bramford to Norwich refurbishment¹ – the existing 98 km route is being upgraded to bring it to modern standards and allow more energy to flow through it. Expected to be complete in Summer 2024.
- **Proposed new requirements** by NGET. An upgrade of existing substations at Norwich and Bramford to provide more capacity at the existing sites (due to be operational in 2028).
 A new transmission circuit between Bramford and Twinstead¹. This 400 kV route is 29 km in length and is a mixture of 18 km of overhead lines and 11 km of underground cabling. This is currently with the Planning Inspectorate under the Development Consent Order (DCO) process and subject to their determination this circuit is expected to be operational by 2028. The Electricity System Operator (ESO) has provided the economic needs case for this circuit on page 13.
 A new transmission circuit between Norwich to Tilbury. This 400 kV overhead route is 183 km in length and is due to be operational by 2030, subject to planning. This would include substation upgrades at Norwich, Bramford and Tilbury; and a new substation proposed in North Essex called 'East Anglia Connection Node' (EACN). This route was previously known as 'East Anglia GREEN'.
- - - **A new subsea cable** named Sea Link¹ between a proposed substation at Friston in Suffolk and Richborough in Kent. This high voltage direct current (HVDC) offshore circuit is 145 km in length and due to be operational by 2030, subject to planning.

Electricity network requirements beyond the 2030s

The current electricity transmission cycle (known as the second Transitional Centralised Strategic Network Plan) is currently being finalised by us, the ESO, with an expected publication due in March 2024. This transmission planning cycle has focused on reinforcements the electricity network needs throughout the 2030s across Great Britain.

Economic needs case for Bramford to Twinstead

Bramford to Twinstead is a new 400 kV overhead Line being developed by NGET. The current capital cost of delivering the project is anticipated to be approximately £500 million. As a solution to the issue of exporting power from East Anglia, the option has been proposed for several years. Since the *Network Option Assessment* published in January 2019, we have seen a strong economic need for Bramford to Twinstead, and for this to be delivered by 2028.

The development of Bramford to Twinstead is well advanced, and NGET have submitted the Development Consent Order (DCO) to the planning inspectorate. Changing Bramford to Twinstead at this stage, would mean an alternative is unlikely to be delivered until beyond 2030. Our analysis of flows in the region, shows this would have a very significant cost to consumers - through additional constraint costs, lost low carbon energy, and wasted spend on the Bramford to Twinstead Network Optimisation (BTNO) project.

In the NOA7, BTNO received a proceed signal, and was shown to be optimal (e.g., required on its earliest in-service date) in all future energy scenarios in the economic analysis. The quantity of generation in these scenarios (based on FES 21) were notably lower than what is now expected to connect in East Anglia even before moving connections under OCSS. These higher values of generation in the region, strengthen the case for more capacity out of the region, such as that provided by Bramford to Twinstead.

In *NOA7 Refresh 2021/22*, BTNO received a 'Holistic Network Design (HND) essential option' signal meaning it is needed to ensure the compliance of the network.

Bramford to Twinstead, together with some other small developments provides around 3.6 GW of additional export capacity out of the region.



Figure 5 Future power flow expectations and requirements from the region

In the Transmission Works Register¹, Bramford to Twinstead is listed as transmission reinforcement schemes being carried out to facilitate generator connections. Bramford to Twinstead facilitates the connection of 9.5 GW of low-carbon and supporting technologies. This comprises of 4.3 GW of offshore wind, 3.5 GW of combined solar / battery projects, and 1.7 GW of battery storage projects. Previous studies have found that a one-year delay to delivering Bramford to Twinstead would cost consumers £25 million in constraint costs. From Figure 5, under all scenarios the existing capacity of the network is insufficient, and Bramford to Twinstead will add additional capability from later this decade onward.

3. Study introduction

Exploration of voluntary offshore coordination off the coast of East Anglia

Offshore wind farms off the coast of the region were deemed in scope of the early opportunities workstream due to their participation in early seabed leasing rounds run by The Crown Estate. This workstream led by the UK Government is part of the Offshore Transmission Network Review (OTNR). This workstream incentivised voluntary offshore coordination⁹.

As announced¹⁰ by the Department for Energy Security and Net Zero in July 2022, five projects within East Anglia agreed to commit to exploring voluntary coordinated network designs under the Government led OTNR. These projects were North Falls Offshore Wind Farm, Five Estuaries Offshore Wind Farm, National Grid Ventures (Lion Link¹¹ and Nautilus) along with National Grid Electricity Transmission (NGET(Sea Link)).

Overall, there were a number of design options proposed and assessed by these developers within East Anglia which consisted of offshore hybrid assets (OHAs) and sharing of onshore convertor station location and connection into Sea Link, a 2 GW high voltage direct current (HVDC) link between Suffolk and Kent designed to alleviate network constraints within East Anglia region.

The Early Opportunities workstream and the subsequent OCSS are UK Government-led workstreams, independent of the ESO. We were asked to provide constraint analysis to this workstream but were not privy to any design options created and subsequently taken forward by the relevant developers.

Offshore Coordination Support Scheme outcome

The conclusion of the analysis carried out by these developers resulted in one solution being proposed and deemed suitable for further development through the Offshore Coordination Support Scheme (OCSS).

The eligibility for schemes under the OCSS was outlined by the Government, and in particular criteria seven¹² said that the coordinated project must show the potential for a demonstrable reduction to cumulative onshore and offshore assets versus the alternative where relevant projects pursue radial or single purpose offshore transmission proposals.

As confirmed¹³ by the Department for Energy Security and Net Zero on 5 December 2023, the outcome of the first exploratory stage of the OCSS has seen a proposal being put forward by North Falls Offshore Wind Farm, Five Estuaries Offshore Wind Farms and NGET (for their Sea Link project) to explore voluntary offshore coordination.

The proposal is for the two offshore wind farms to be coordinated. We have modelled this as the two wind farms connecting into an offshore platform into Sea Link (a new 2 GW HVDC circuit from the proposed Friston substation to Richborough in development by NGET). The current connection agreements have the two offshore wind farms connected to a proposed 'East Anglia Connection Node' (EACN) being planned in North Essex, on a new 400 kV overhead circuit from Norwich-Bramford-Tilbury.

⁹ This consequently meant the offshore wind farms in development around those shores were deemed out of scope of the later stage workstream of OTNR, that enabled the creation of Holistic Network Design (HND) and its follow up exercises.

¹⁰ [Joint statement from North Falls, Five Estuaries and National Grid: Commitment to exploring coordinated network designs in East Anglia - GOV.UK \(www.gov.uk\)](https://www.gov.uk/government/news/joint-statement-from-north-falls-five-estuaries-and-national-grid-commitment-to-exploring-coordinated-network-designs-in-east-anglia)

¹¹ formerly named Euro Link

¹² [Offshore Coordination Support Scheme guidance \(publishing.service.gov.uk\)](https://publishing.service.gov.uk/government/uploads/system/uploads/attachment_data/file/118444/offshore-coordination-support-scheme-guidance)

¹³ Joint Statement

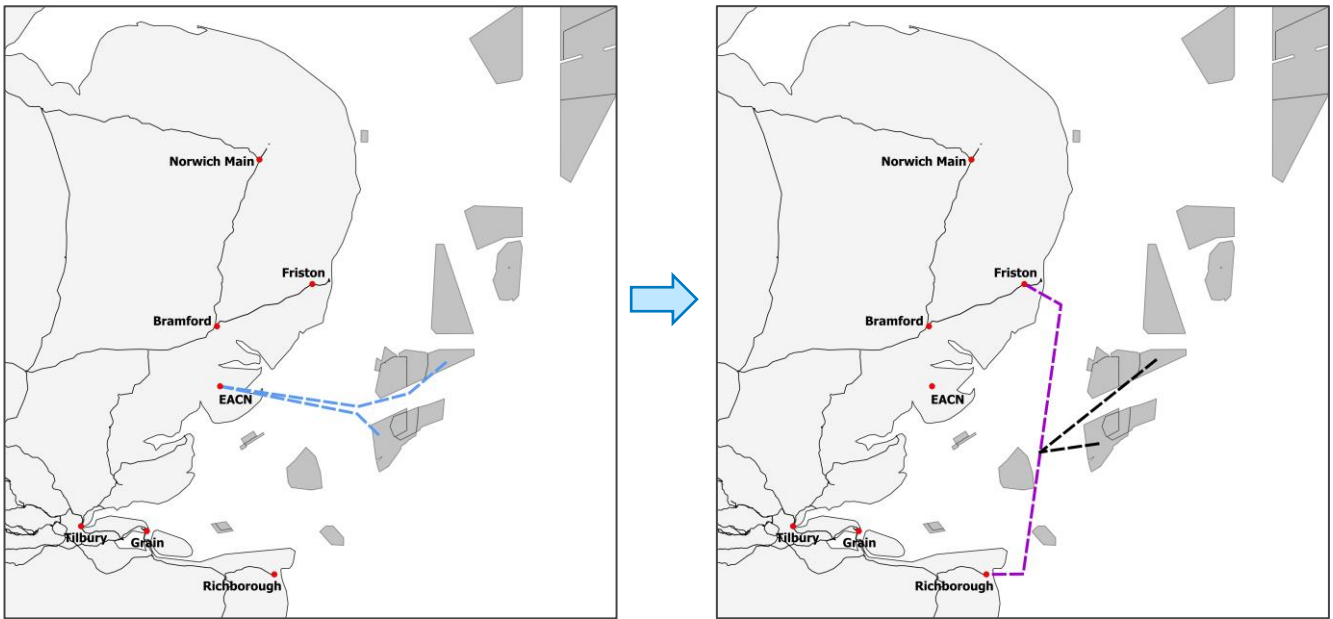

Figure 6: Map of North Falls and Five Estuaries offshore wind farms off the Suffolk/ Essex coast, and the indicative location of their contracted connection point to the transmission network prior to OCSS – the proposed substation at the East Anglia Connection Node, in North Essex

The wind farm developers and NGET are continuing to assess the feasibility of the proposed coordination over the course of 2024. UK Government will then take a view as to whether to continue to fund the exploration of this voluntary coordination.

It is important to note that a decision from government to grant OCSS funding does not result in immediate or automatic changes to existing, signed connection agreements between us and offshore wind projects. It is our understanding that all developers in scope of the OCSS are pursuing the exploration of voluntary offshore coordination alongside progressing their existing connection agreements.

Rationale for the Electricity System Operator’s (ESO’s) East Anglia network study

Separately, following the Offshore Coordination Support Scheme (OCSS) announcement, we agreed to study whether this change in connection location (due to the coordination proposed through the OCSS) changes the underlying power flows within the region.

The starting point for this study is therefore the change in power flows that have come from the changes in connection location of the North Falls and Five Estuaries offshore wind farms. Therefore, for the purposes of this assessment we have assumed that these offshore wind farms are connecting into Sea Link and not their currently contracted connection location at the proposed East Anglia Connection Node.

This study is separate from and independent of the electricity transmission network planning cycle. The ESO will not as a result of this study be making recommendations to relevant parties on which network option they should proceed with. The analysis within this report will be considered by NGET, the Transmission Owner. It will also be publicly available for consideration by other interested parties, should the OCSS coordination take place.

Study scope - What have we assessed?

The objective of this study is to provide a side-by-side holistic comparison of different electricity network configuration options that transfer power across or around the region. There are three core elements to this assessment which are as follows:

- Network technology capability assessment.
- A preliminary screening assessment of options submitted to us for consideration.
- A holistic assessment of network configuration options.

4. Network technology capability assessment

In order to get an independent view of different electricity network technologies to help aid our assessment¹⁴, we asked DNV, an independent engineering consultancy firm, to provide their view of different network technology choices available on the market as well as next generation technologies not yet currently deployed.

Electricity network technologies used regularly in Great Britain

The three main current technologies used in Great Britain, and included within this study, are:

- Alternating current overhead line (AC OHL)
- Alternating current underground onshore cables (AC UGC)
- High voltage direct current link with offshore cables (HVDC).

The main technology used for the transmission network in Great Britain is AC overhead lines. These form the 275 kV and 400 kV supergrid built in the 1950s and 1960s to connect fossil fuel generation to areas of electricity demand. The majority of this network is overhead lines supported by lattice towers. Some elements of the network are undergrounded, typically through areas of designated landscape, or in very congested areas such as cities¹⁵.

The ‘National Policy Statement for electricity networks infrastructure’ (NPS)¹⁶ provides government planning guidance for developers of nationally significant electricity network infrastructure projects. It states that the UK Government’s position is the use of overhead lines as the starting presumption for electricity network development. The NPS also explains when technologies such as underground onshore cables, or subsea offshore cables may be a viable alternative.

HVDC is a newer technology, primarily used for bulk power transfer over longer distances due to the lower losses of electricity compared to AC. HVDC can also connect ‘non-synchronous’ power regions – such as Great Britain to Ireland, or Great Britain to mainland Europe which can operate at slightly different frequencies.

HVDC technology is in use in Great Britain off the west coast from Hunterston to Connah’s Quay (known as the Western Link) and from Spittal to Blackhillock across the Moray Firth in Northern Scotland (known as the Caithness to Moray HVDC line). New HVDC lines are planned as part of the Pathway to 2030 Holistic Network Design, including links on the east coast from Scotland to England.

Below is a table setting out DNV’s key comparisons between these technologies, more detailed analysis can be found within the report’s appendix.

Characteristic	AC OHL	AC UGC	HVDC (VSC ¹⁷)
Archetype Description			
Maximum continuous	>6,000 MVA	>6,000 MVA ¹⁸	2,000 MVA

¹⁴ Please note: this network technology capability assessment is not an assessment of how the technologies perform as part of wider solutions, it is simply a unit cost comparison that is true regardless of how it is deployed.

¹⁵ AC network technology can also be used for short distances offshore. However as this is not a technology utilised for the purposes of this study, it is not included within DNV’s assessment.

¹⁶ [National Policy Statement for electricity networks infrastructure \(EN-5\) - GOV.UK \(www.gov.uk\)](https://www.gov.uk/government/uploads/system/uploads/attachment_data/file/442222/national-policy-statement-for-electricity-networks-infrastructure-en-5.pdf)

¹⁷ Voltage Source Converter, see details on types of HVDC technology in Section 7

¹⁸ Comprising one or more underground cables per electrical phase

Characteristic	AC OHL	AC UGC	HVDC (VSC ¹⁷)
transmission capacity (MVA)	(per 400 kV double circuit route)	(per 400 kV double circuit route)	(per +/-525 kV bipole circuit route) ¹⁹
Maximum technically feasible route length (km):	Unrestricted - but see note ^{20[3]}	~ 20 km - but see note ²¹	Unrestricted
Lifespan (years)	> 40 years ²²	> 40 years ²³	~ 40 years ^{24[7]}
Infrastructure operational footprint	<ul style="list-style-type: none"> • 50-150sqm land-take per tower, 3 spans per km • Building beneath the overhead line route permanently discouraged, though many agricultural /rural land uses can resume • Periodic vegetation management required 	<ul style="list-style-type: none"> • Building and excavations permanently discouraged within, typically, a 25m wide cable swathe (see DNV report), though many rural/agricultural land uses above ground can resume • Periodic vegetation management may be required 	<ul style="list-style-type: none"> • ~45,000sqm land-take per 2,000 MVA converter station (max. 2 converter stations per circuit) • Building and excavations permanently discouraged within ~10m wide onshore cable swathe, though many rural/agricultural land uses can resume
Future scalability for long-term planning	<ul style="list-style-type: none"> ✓ Uprating (at refurbishment) ✓ Route diversion ✓ Usually less cost and disruption to connect additional generation and demand in the future 	<ul style="list-style-type: none"> ✗ Uprating ✗ Route diversion ✗ Usually more cost and disruption to connect additional generation and demand in future 	<ul style="list-style-type: none"> ✗ Uprating ✗ Route diversion ✗ Impractical to connect additional generation and demand in future
Deliverability and operability			
Planning and consents	<ul style="list-style-type: none"> • An application for a Development Consent Order (DCO) is required • Process complex and time-consuming, could 	<ul style="list-style-type: none"> • Process relatively easier for underground cables • Classed as 'permitted development' • Any sealing end compounds may require planning permission 	<ul style="list-style-type: none"> • Subject to all usual planning procedures for onshore and offshore connections • Planning consent for a converter station can vary very considerably and subject to significant delays

²⁰ En-route compensation stations may be required beyond about 200 km route length.

²¹ Beyond around 20 km route length, a 400 kV AC underground cable circuit would need intermediate compensation so, technically, interfaces with the network become increasingly complex and costly.

²² Major refurbishment(s) of overhead line conductor systems at around 40-year intervals are expected to extend overhead line lives to 80 or even 120 years.

²³ XLPE cable technology track record for transmission voltages is still developing, but early indications are that these cables could possibly reach 80-year lives, or more, without major refurbishment.

²⁴ HVDC expected to require a major refurbishment at around 20 years to achieve this design life.

Characteristic	AC OHL	AC UGC	HVDC (VSC ¹⁷)
	<ul style="list-style-type: none"> sometimes lead to public inquiry Compulsory purchase authority may be used in special circumstances 	<ul style="list-style-type: none"> Suitable rights over land (wayleaves and easements) are needed, often granted voluntarily 	<ul style="list-style-type: none"> Complex consent process for offshore power cables due to requirements for 'no disruption' assurance to other linear services (including power, telecoms, gas, oil), other sea users, plans for the seabed and sea life A National Competent Authority (NCA) will provide the final approval for projects in England
Reliability, availability and maintainability	<ul style="list-style-type: none"> Robust operation - auto-reclose for lightning strikes Physical damage normally repaired within hours or days (excessive damage within weeks) Maintenance; three days pa (average) 	<ul style="list-style-type: none"> Reliable operation Physical damage repaired within days (excessive damage within weeks) Maintenance; 3 days pa (average) 	<ul style="list-style-type: none"> Reliable operation (however limited-service experience) Physical damage to converter repaired within hours or days Physical damage to cable repaired within months Maintenance; 10 days pa (average)
Flexible circuit rating	<ul style="list-style-type: none"> Up to 35% above rating for short period. 	<ul style="list-style-type: none"> Up to 30% above rating for short period. 	<ul style="list-style-type: none"> None
Environmental impacts¹			
Construction	<ul style="list-style-type: none"> Traffic noise and dust Access may impact vegetation/habitats Potential impact on biodiversity (habitat loss) Construction activities contribute to Greenhouse Gas (GHG) emissions 	<ul style="list-style-type: none"> Traffic noise and dust Excavation activities may lead to soil disturbance, vegetation removal and habitat loss Construction activities contribute to GHG emissions 	<ul style="list-style-type: none"> Traffic noise and dust Potential impact on marine species and seabed disturbance Construction activities contribute to GHG emissions and water pollution
Operational	<ul style="list-style-type: none"> Acoustic noise (poor weather crackle) Potential impact on bird species (collision risk) 	<ul style="list-style-type: none"> Cable access points will require vegetation clearance 	<ul style="list-style-type: none"> Acoustic noise and vibration impact (permanent hum) on biodiversity Vessel traffic
Community impacts¹			
Construction:	<ul style="list-style-type: none"> Minimal traffic disruption 	<ul style="list-style-type: none"> Traffic disruption Potential land use disruptions due to cable 	<ul style="list-style-type: none"> Traffic disruption Disruption to economic activities such as fishing

Characteristic	AC OHL	AC UGC	HVDC (VSC ¹⁷)
	<ul style="list-style-type: none"> Land use disruptions Less impact in rural areas, higher impact in urban due to population proximity 	<ul style="list-style-type: none"> trenching (depending on the route selected) Less impact in rural areas, higher impact in urban 	<ul style="list-style-type: none"> Low impact on both rural and urban areas, but higher impact on both with installation of new supporting infrastructure (if required)
Operational:	<ul style="list-style-type: none"> Tower ground footprint occupied Potential to depress property values Building on route denied Visual impact Potential 50Hz EMF exposure Noise propagation 	<ul style="list-style-type: none"> Building on cable route denied Potential 50Hz magnetic field exposure 	<ul style="list-style-type: none"> Converter station ground footprint occupied Building on cable route denied Converter station visual impact Potential DC magnetic field exposure
Cost magnitude comparison factors for a 75 km 6,380 MVA / 6,000 MW transmission route (per unit)²⁵			
Lifetime archetype costs:	x 1	x 4.7	x 8 ²⁶
Lifetime losses costs:	x 1	x 0.8	x 1.6 ²⁷
Commercial and supply chain			
	<ul style="list-style-type: none"> Currently, no known supply issues for overhead line – key dependencies are supplies of aluminum and steel 	<ul style="list-style-type: none"> Long UGC installations may suffer extended delivery lead times Reactive compensation required for long cable installations that may suffer extended delivery lead times 	<ul style="list-style-type: none"> There are presently three competitive 2000MW VSC HVDC converter suppliers As global demand rises (as expected in the near future), converter delivery lead times are expected to lengthen Key issue for HVDC links is presently the lack of submarine cable manufacturing capacity. Delivery lead times are already extended 2-3 years beyond normal, and likely to further increase until new production comes online around 2030

Table 3: Unit comparison (AC overhead line, AC underground cable, HVDC link with offshore cables)

As the above table illustrates, there are trade-offs between the different types of network technologies and the choice to be made between them depends on where and when the infrastructure is being deployed. From a high-level perspective, the following are the summary findings for each technology.

²⁵ Based on cost analysis in Section 4, for all three technologies the minimum values tend to reflect the longest route length, while the maximum costs tend to associate with the shortest route length. It should be noted that these cost comparisons are generalised; they are based upon many assumptions, and they are not associated with a specific application or location. For this reason, they should be treated as indicative only

²⁶ In practice this 6,000 MW capacity would probably be realised with 3 x 2MW HVDC links. This cost factor includes an allowance for mid-life refurbishment of the converter electronics.

²⁷ Mainly due to losses from converter station

- The lowest cost and least environmentally impactful are AC overhead lines, however they are the most visually intrusive once built.
- Underground AC circuits are more expensive solutions and more environmentally damaging during the construction phase. They are also potentially technical viable only for shorter routes (typically of less than 20 km) however they are less visually intrusive once built.
- HVDC is the most feasible technology for longer circuits where a cable solution is necessary, and it offers important operational benefits compared to AC equivalents over such distances, such as the direct control of power flow and dynamic voltage support, it is also more expensive option (per installed km) compared to an AC alternative, and it is the most inflexible to adapt if the network requirements change over the lifetime of the asset.
- The maximum ratings of present HVDC technology are lower than AC circuits, which means that to achieve the same transmission capability, multiple HVDC circuits would be required.
- All three technology types need to comply with transmission licensing, technical codes and engineering policies. The regulations apply equally.

5. Preliminary assessment of proposed options

Over the three-month study period, five alternative ‘network’ options were submitted to us by community representatives for our consideration. These were:

- Proposed Option: A predominantly onshore option without East Anglia Connection Node (EACN).
- Proposed Option: Two or more multi-purpose interconnectors (MPIs) with wind farms connecting into them, utilising Bradwell in Essex as an onshore interface point as well as areas in Kent.
- Proposed Option: An undergrounded high voltage direct current (HVDC) cable stretching from Norwich in Norfolk to Tilbury in Essex.
- Proposing Option: A predominantly offshore option - Utilising Bradwell in Essex as an interface point for HVDC cables.
- Proposed Option: An offshore ring main, connecting all wind farms around the coast of the region, utilising brownfield sites for onshore interface points, such as Bradwell and areas in Kent.

Preliminary assessment process

To determine whether options submitted to us should be taken forward to the next stage of holistic assessment, we have screened these options against the below criteria as outlined within the table below.

	Proposed Option	Proposed Option	Proposed Option	Proposed Option	Proposed Option
Description	Onshore option without EACN	Two or more MPIs	Underground onshore HVDC	Predominantly offshore option - Utilising Bradwell as a landing point	An offshore ring main
Is this proposal in scope of the study’s Terms of Reference ²⁸ ?	Yes	No	Yes	Yes - if Bradwell is hosting transmission infrastructure, no if it is hosting generation infrastructure.	No
Would the proposal require a change in connection location for projects not exploring voluntary coordination through the OCSS?	Within the sensitivity range of the study	Yes	No	No – if only wider network HVDC landing points were considered.	Yes

²⁸ East Anglia Study – Terms of Reference - [download \(nationalgrideso.com\)](https://www.nationalgrideso.com)

	Proposed Option	Proposed Option	Proposed Option	Proposed Option	Proposed Option
Description	Onshore option without EACN	Two or more MPIs	Underground onshore HVDC	Predominantly offshore option - Utilising Bradwell as a landing point	An offshore ring main
Is the proposal technically feasible in the timescales the capacity is needed?	Yes	Yes - if regulatory regime is in place	Yes	Yes	No
Progression to next stage of assessment	Yes	No	Yes	Yes – if the proposal is only moving network transmission infrastructure to Bradwell	No

Table 4: Summary of the Gate 1 assessment of the proposals.

6. Holistic Assessment

Methodology for holistic assessment



The design criteria methodology we use helps us to balance the impacts of new infrastructure with the benefits it can bring. This methodology was originally approved by the UK Government as part of their Offshore Transmission Network Review (OTNR) and later adopted into our wider onshore network planning process. Our equally weighted design criteria for new infrastructure are:

- Criteria 1: Can be delivered and operated in a timely and practical way.
- Criteria 2: Minimise the impact, where possible, on the natural environment.
- Criteria 3: Minimise the impact, where possible, on the communities that host this infrastructure.
- Criteria 4: Can be delivered in an economic and efficient way, ensuring the best value for consumers.

As this is still the first step in the electricity transmission network planning cycle, it is important to emphasize that the holistic assessment is based on high level study areas (often using geospatial data), not route corridors. If these network options are progressed further by the relevant Transmission Owner they will undertake more detailed assessments, to help determine any potential cumulative as well as specific community impact and local environmental constraints.

The assessment used a combination of financial information about the designs e.g. capital infrastructure costs and operational costs to determine the value of each design in terms of net present value (NPV). The NPV enabled us to compare the economics across each design.

To assess and compare the deliverability and operability, environmental impact, and community impact, we used Black, Red, Amber, or Green (BRAG). Definitions of the BRAG ratings are provided below:

BRAG Ranking		
	Black	The design is not viable in its current state from an environmental/community/deliverability and operability perspective due to environmental/community/deliverability issues.
	Red	The design has a high level of constraints from an environmental/community/deliverability and operability perspective and is potentially viable, however will have to overcome many environmental/community/deliverability issues.
	Amber	The design has a medium level of constraints from an environmental/community/deliverability and operability perspective and is

		likely to be viable, however may have to overcome some environmental/community/deliverability issues
	Green	The design has a low level of constraints from an environmental/community/deliverability and operability perspective and is likely to be viable without any major environmental/community/deliverability issues.

Table 5: Definitions of BRAG ratings

The BRAG is also applied to subparts of the ratings, and the overall deliverability, environmental and community is taken as the cumulative impact of the subparts. In general, the most severe rating of a subpart applies to the rating of the whole option.

To assess and compare the economic impact, we have presented two rankings in this report. Further details and sensitivities are contained in the appendix. We have compared the capital cost of delivering each option, with the benefit it brings in reducing constraints. This is a lifetime cost measure – the cost of building an option plus the constraints remaining. We present that costs in comparison to the cheapest option, which in this assessment is Option 3. We have secondly compared the options as if they were all delivered in 2034, to assess the impact if options delivered earlier where to be delayed. As additional lifetime costs range from £0bn to over £10bn, we have divided the range in to three for the RAG status: £0-£3bn Green; £3bn-£7bn Amber; £7bn or above Red.

In the appendix, we have included further economic analysis including sensitivities to other generation and demand scenario, the impact of new strategic demand and changes in constraint and capital cost.

As the starting assumption for this study is that Offshore Coordination Support Scheme (OCSS) has happened, any costs associated with changes to Sea Link or other coordination costs (which would be common across options) are not included.

Additional assessment - community sentiment

In addition to the assessment criteria set out above, we have also assessed the community sentiment of all options, set out in the result below. This has followed from engagement we have undertaken with a range of community and elected representatives. We are, however, unable to quantify this assessment and represent the views of the whole community. We have therefore included this separately below.

Options under holistic assessment

Following the preliminary screening assessment, network configuration options have undergone holistic assessment using the above methodology.

These are set out below²⁹:

1. Predominately offshore option – variation without EACN
2. Predominately offshore option – variation with EACN
3. Onshore option
4. Alternative onshore option – variation without Bramford to EACN
5. Alternative onshore option – variation without EACN
 - b. Alternative onshore option – variation without EACN – sensitivity
6. Hybrid onshore and offshore option – variation with EACN
7. Hybrid onshore and offshore option – variation without EACN
8. Onshore HVDC option
9. Predominantly offshore option – Utilising Bradwell as a landing point.

These network configuration options are a variation of on and offshore circuit options that transfer power across or around the region. The options have been tested against multiple variables such as:

- Different background assumptions of supply and demand through Future Energy Scenarios

²⁹ Option 5, 8 and 9 correspond to Proposal P5, P3 and P4 respectively.

- Different commissioning dates for new elements of the network infrastructure
- Additional growth in large strategic demand such as data centres or hydrogen electrolyzers

The options have also been benchmarked against standard costs, sliding timelines of delivery and how that impacts costs, as well as similar projects elsewhere across Great Britain and beyond. Feedback provided by stakeholders on the proposed circuit options have been accounted for within the report under the community sentiment metric.

Assumptions relating to grid connections, network requirements and delivery dates for options under holistic assessment

Offshore wind farms

In all ten circuit configuration options set out below, each offshore wind farm is assumed to connect at their current contractual location as set out in their connection agreement³⁰ apart from North Falls and Five Estuaries offshore wind farms. These two wind farms are modelled as connected into Sea Link in all ten network configuration options, as per their voluntary exploration of coordination through the OCSS.

All other generation and demand, nationally and locally, connects according to the locations in our Future Energy Scenarios³¹ which is consistent with our overall approach to network planning.

Interconnectors

There are three proposed interconnectors with connections in the region³². Contractually, two interconnectors have connections³³ at Friston (Nautilus and Lionlink), and one has a connection at EACN (Tarchon). Nautilus's developer has said³⁴ they are also investigating changing their connection location to Isle of Grain in Kent, we have therefore modelled this interconnector at both Friston and the Isle of Grain.

As a result of the OCSS process, Tarchon interconnector is the only party left connecting at the proposed East Anglia Connection Node. The OCSS drives no other similar change we have therefore conducted sensitivity analysis as to whether the interconnector connects at that proposed node or elsewhere.

In terms of the connection locations for interconnectors:

- In most options where EACN is constructed, the three interconnectors connect at contracted position (one at EACN, and two at Friston). These are options 3,4,6 and 8.
- In options where EACN is not constructed, we assume two interconnectors at Friston (unchanged) and one at Grain). These are options 1, 5 and 7.
 - We have conducted a sensitivity analysis on option 5 to assume three interconnectors behind the EC5 electrical boundary – known as option 5b.
- In option 2, where EACN is constructed, one interconnector is connected as each of EACN, Friston and Grain. This is because otherwise, three interconnectors would be connected in proximity between Friston and Bramford which would likely trigger the need to upgrade the onshore network further.
- In option 9, as we are exploring Bradwell as a landing site, it is assumed one interconnector lands at Bradwell, one at Grain and one at Friston.

As stated previously, we, as the ESO cannot unilaterally compel Nautilus or Tarchon to move connection locations³⁵.

Why is a potential new circuit required from Friston to EACN in some options?

In all the options (except for option 9), a new route is shown as being required from Friston either onshore to EACN or offshore to (nominally) Sellindge in Kent. The need for one of these circuits is triggered by the

³⁰ https://www.nationalgrideso.com/data-portal/transmission-entry-capacity-tec-register/tec_register

³¹ <https://www.nationalgrideso.com/future-energy/future-energy-scenarios-fes>

³² An interconnector is an HVDC cable that connects the GB power system to the power system of another country and are developed under Ofgem's Cap and Floor regime.

³³ <https://www.nationalgrideso.com/data-portal/interconnector-register>

³⁴ [About Nautilus | National Grid Group](#)

³⁵ This assessment was conducted prior to Ofgem's interconnector cap and floor announcement.

changes in the location of generation proposed by OCSS, which brings further generation (North Falls and Five Estuaries) linked to the proposed Friston substation via Sea Link.

The following table summarises the existing and planned generation and interconnectors at Sizewell, Leiston and proposed Friston substations:

	Already Connected	Planned
Sizewell	<ul style="list-style-type: none"> • Sizewell B nuclear power station 	<ul style="list-style-type: none"> • Sizewell C nuclear power station
Leiston	<ul style="list-style-type: none"> • Galloper offshore wind farm • Greater Gabbard offshore wind farm 	
Friston (proposed)		<ul style="list-style-type: none"> • East Anglia One North offshore wind farm • East Anglia Two offshore wind farm • Nautilus interconnector³⁶ • Lionlink interconnector • Sea Link HVDC, which connects to North Falls and Five Estuaries offshore wind farms (under OCSS)

Table 6: Generation and Interconnection planned for existing Sizewell and Leiston substation, and proposed substation at Friston

The existing route for power out of the region is two double overhead circuits from Sizewell to Bramford, where it connects to the rest of the electricity network. In this study, Sea Link is always required to be built to provide generation connections for North Falls and Five Estuaries.

In designing the network to account for this change in generation connection, the system must be robust to faults and temporary loss of parts of the network – this is so continuity of supply is maintained. The Security and Quality of Supply Standard³⁷ (SQSS) provide the standard for how connections and the wider network need to be designed; and in particular under which faults on the network we cannot have a large loss of generation. For this area local to Sizewell, there are two credible faults to consider – (i) a fault of one of the double circuit overhead lines, or (ii) a fault on Sea Link which means all the power from the wind farms must flow north.

Under projection for the mid 2030s, there is around 9.4 GW of generation in the region, plus interconnectors. For the highest power flow and transmission loading case, we assume full generation output meaning around 9.4 GW of power to take out of the region³⁸ which includes output from North Falls and Five Estuaries which have moved to the area under OCSS. Broadly, under a fully intact (without any disconnected circuits) network (2 x double circuits, plus Sea Link) a total of 14 GW of power could be exported from the region.

However, we must secure the network under fault conditions to ensure that generation remains connected:

- Under a fault of one of the existing double circuit overhead lines out of the region the export capacity of the area reduces to around 8 GW (one double circuit plus Sea Link) which is less than the generation connected. This is not an acceptable fault condition under the SQSS and must be avoided.
- Under a fault of Sea Link, there is sufficient capacity to export the generation via the remaining double circuit overhead lines.

It also follows that if less generation were to connect then the need for an additional circuit, based on ‘fault conditions’, may be removed. In the situation without OCSS an additional circuit is not required.

The need for the additional circuit is the cumulative impacts of all the generation connected / connecting at Friston, Leiston and Sizewell (including North Falls and Five Estuaries under OCSS), but it is likely to be ‘required’ for operation only when Sizewell C Nuclear Power Station connects (as this is the last of the

³⁶ The developer, NGV have discussed moving the connection for *Nautilus* from Friston to the Isle of Grain, they still hold a contractual agreement to connect at Friston.

³⁷ [Security and Quality of Supply Standard \(SQSS\) | ESO \(nationalgrideso.com\)](https://www.eso.co.uk/Security-and-Quality-of-Supply-Standard-(SQSS)-|-ESO-(nationalgrideso.com))

³⁸ There is minimal local demand in the region.

proposed connections to connect³⁹), hence a delivery date of 2034 is acceptable for that line (see delivery dates below).

This additional circuit out of the Sizewell/Friston area can either be an onshore route to the EACN, or as a second HVDC line from Friston to (indicatively) Sellindge as in the previous options. If it were an onshore route, the default in planning is that it would be an overhead line, with some portions potentially undergrounded.

Delivery Dates

Delivery dates for each option are based on several elements. In each option Sea Link is assumed to deliver its base capability in 2030, and then take an outage in 2032 to integrate North Falls and Five Estuaries offshore wind farms. After this, Sea Link returns but provides reduced capacity, as it is now dual purpose as both a route to move power to and from the region, and a connection point for offshore wind.

The current projected timescale for the delivery of Norwich to Tilbury is 2030. This applies to parts of the route such as Norwich to Bramford, Bramford to EACN, and EACN to Tilbury.

For other new or substantially new circuits, such as the new offshore proposed lines, the Friston to EACN, or Friston to Tilbury routes, which have not been subject to any detailed engineering, consultation or consenting, these are assumed to be delivered by 2034 at the earliest.

All delivery date assumptions are based on technical assessment, a planning process which runs 'to time', and a supply chain which is able to deliver what is required. The risk to consenting and supply chain are captured in the deliverability assessment.

We have undertaken a sensitivity if the 2030 onshore elements were delayed. This will provide a direct comparison of if all projects were delivered in 2034 as requested by stakeholder.

³⁹ Sizewell C has a contractual connection date of 2029 and 2030 in the TEC register. However, the developer have said a ten to twelve year build from construction which has recently commenced [edfenergy.com/sites/default/files/szc-esg-brochure.pdf](https://www.edfenergy.com/sites/default/files/szc-esg-brochure.pdf)

Options Assessment

1. Predominately offshore option – variation without EACN

<p>Figure 7: Map showing Option 1: Predominantly offshore option – variation without EACN</p>	<p>Option Description</p> <p>This network configuration has four circuits and is a predominantly offshore option, with no additional overhead lines proposed in East Anglia.</p> <p>There are two proposed onshore starting points for undersea cables, beginning at Norwich and Frinton that will be undergrounded to the coast and continue offshore in the sea to three onshore locations in Kent - Grain, Richborough and (nominally) Sellindge.</p>	
	<p>Technology</p> <ul style="list-style-type: none"> • Two 2 GW HVDC links from Norwich to Grain, providing 4 GW of capacity with HVDC converter stations to be built at both ends of the link. • One 2 GW HVDC link from Frinton to (nominally) Sellindge with HVDC converter stations to be built at both ends of the link. • One 2 GW HVDC link from Frinton to Richborough into which North Falls and Five Estuaries connect into Sea Link. This will also need HVDC converter stations to be built at both ends of the link. 	
	<p>Delivery Date</p>	<p>2034 (with Sea Link delivered earlier)</p>
	<p>Capital Cost</p>	<p>£5.8bn</p>

Legend	
	Existing Transmission Network
	Proposed AC circuit
	Proposed HVDC circuit
	Coordination from North Falls / Five Estuaries & Sealink
	Key Substations (p = proposed)
	Interconnector connection points

Option 1			
Design Criteria	Ranking	Sub Description	Commentary
Deliverability & Operability	Red	Supply chain, deliverability, and operability	Challenging delivery with multiple offshore HVDC circuits. Limited suppliers of HVDC and known supply chain delays. Complex operation to coordinate all HVDC circuit power flows. This drives the Red rating.

		Consenting	The solution is predominantly offshore, and so consenting is believed to present complexity, especially around areas with a concentration of infrastructure such as Friston.
Environmental	Red	Norwich to Grain	Norwich to Grain must first traverse underground to the shore (avoiding The Broads), and through a complex marine environment comprising of extensive and overlapping SACs, SPAs, MCZs and SSSIs, resulting in its Red rating.
		Friston to Richborough	As the Norwich to Grain route makes up a significant proportion of this option, and considering the complexity of mitigations in the marine environment compared to on land, the overall rating is assessed to be Red.
		Friston to nominally Sellindge	A Red rating means this option is heavily constrained, it is potentially viable, however will have to overcome many environmental issues.
Community	Amber	Norwich to Grain	All the routes featured in this option are predominantly offshore routes. As such, the overall community impact is moderately constrained for this option. Some significant impact is possible at the coastal interface, and avoidance of constraints may be challenging, but should still be possible at the detailed routeing stage of the design process.
		Friston to Richborough	
		Friston to nominally Sellindge	
Economic	Economic Rank	£4.2bn	The options received an Amber rating costing £4.2bn more over its lifetime compared to the cheapest option (Option 3 delivered in 2030). This option is delivered in full by 2034. It is one of the most expensive options driven by the cost of converter stations and HVDC subsea cabling. It is effective at reducing constraints but not sufficient to offset the additional CAPEX, or the delayed delivered.
	Delay Impact	£4.2bn	There is no change in the relative economic position of this option if all options are considered delivered in 2034.
Community Sentiment	Amber	This option negates the need for new overhead lines – removing visual impact; however, it has significant concentrated impact at proposed coastal nodes.	

2. Predominately offshore option – variation with EACN

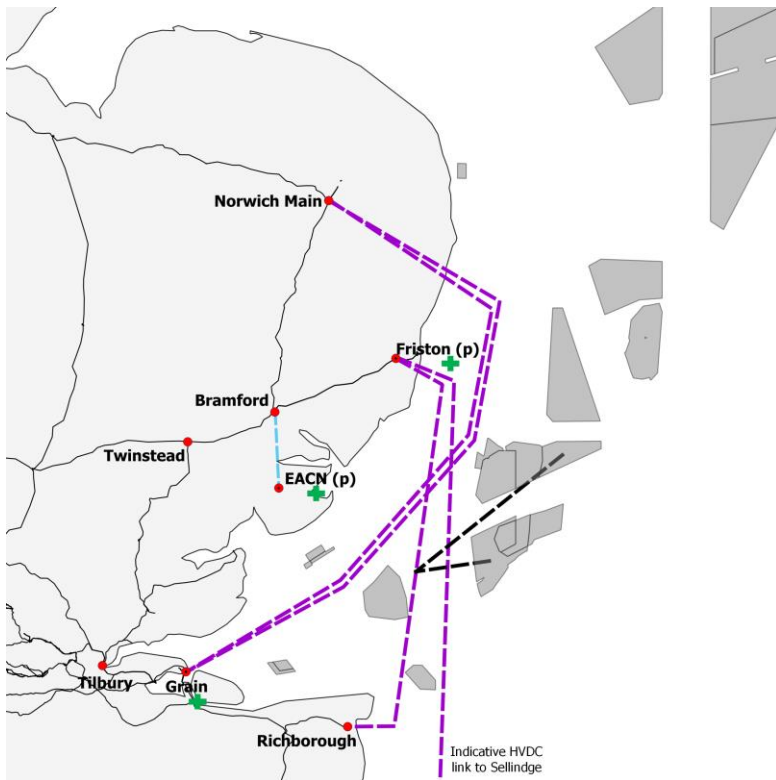

Figure 8: Map showing Option 2: Predominantly offshore option with EACN

Legend	
	Existing Transmission Network
	Proposed AC circuit
	Proposed HVDC circuit
	Coordination from North Falls / Five Estuaries & Sealink
	Key Substations (p = proposed)
	Interconnector connection points

Option Description

This network configuration has five circuits. These circuits would begin at Norwich and Freston and will be undergrounded to the coast and continue offshore in the sea to three onshore locations in Kent - Grain, Richborough and (nominally) Sellindge.

It also has an onshore circuit to connect the proposed EACN substation to Bramford substation.

Technology

- Two 2 GW HVDC links from Norwich to Grain, providing 4 GW of capacity with HVDC converter stations to be built at both ends of the link.
- One 2 GW HVDC link from Freston to (nominally) Sellindge with HVDC converter stations to be built at both ends of the link.
- One 2 GW HVDC link from Freston to Richborough into which North Falls and Five Estuaries connect, known as Sea Link. This will also need HVDC converter stations to be built at both ends of the link.
- One AC onshore route from the proposed EACN to the Bramford substation. It is likely that this circuit would be part part overhead line, and part underground through the Dedham Vale Area of Outstanding Natural Beauty (AONB)⁴⁰.

Delivery Date	2034 (with Sea Link delivered earlier)
---------------	--

Capital Cost	£5.9bn
--------------	--------

⁴⁰ The ESO have made this assumption as this is similar circuit route to that be proposed by NGET as part of the existing Norwich to Tilbury circuit. Partial undergrounding has been identified through the Dedham Vale Area of Outstanding Natural Beauty (AONB) as part of this circuit.

Option 2			
Design Criteria	Ranking	Sub Description	Commentary
Deliverability & Operability	Red	Supply chain, deliverability, and operability	Challenging delivery with multiple offshore HVDC circuits, and an additional onshore circuit. Limited suppliers of HVDC and known supply chain delays. Complex operation to coordinate all HVDC circuit power flows. This drives the Red rating.
		Consenting	This solution is predominantly offshore, but with an onshore route from Bramford to the EACN, and the associated substation onshore. This is likely to present a level of high complexity around consenting, especially around areas with a concentration of infrastructure such as Friston, and the impact on EACN and the Dedham Vale.
Environmental	Red	Norwich to Grain	<p>Norwich to Grain makes up a significant proportion of this option. The route must first traverse overland (avoiding The Broads), and through a complex marine environment, with the cumulative combination of designations and receptors such as SACs, MCZs and SPAs, mostly in the southern section, causing its Red rating.</p> <p>Because of the significance of the Norwich to Grain route to this option, and considering the complexity of mitigations in the marine environment, the overall rating is assessed to be Red.</p> <p>A Red rating means this option is heavily constrained, it is potentially viable however, will have to overcome many environmental issues.</p>
		Friston to Richborough	
		Friston to nominally Sellindge	
		Bramford to EACN	
Community	Red	Norwich to Grain	<p>Much of this design option is in the marine environment, however considering the significant constraints identified between Bramford and EACN, overall the combination of routes make this option significantly constrained.</p> <p>Some impact will need to be considered at the coastal interface and detailed routeing will need to be carried out to avoid where possible some of the key constraints.</p> <p>Additionally, undergrounding may need to be considered as a mitigation for some of these features, for example Dedham Vale National Landscape, which spans a significant part of the study area.</p>
		Friston to Richborough	
		Friston to nominally Sellindge	
		Bramford to EACN	
Economic	Economic Rank	£4.8bn	<p>The options received an Amber rating costing £4.8bn more over its lifetime compared to the cheapest option (Option 3 delivered in 2030).</p> <p>This option is delivered in full by 2034. It is the most expensive options driven by the cost of converter stations and HVDC subsea cabling, and the onshore route through the Dedham Vale. It is effective at reducing constraints but not sufficient to offset the additional CAPEX. It performs slightly worse than Option 1 as an interconnector is moved out of the region (otherwise there would be too many Interconnectors close to Bramford/Friston), which exports power when there is high wind / low prices in Great Britain.</p>

ESO

Option 2			
	Delay Impact	£4.8bn	There is no change in the relative economic position of this option if all options are considered delivered in 2034.
Community Sentiment	Red	This option involves a short OHL/UG onshore infrastructure through an Area of Outstanding Natural Beauty.	

3. Onshore option

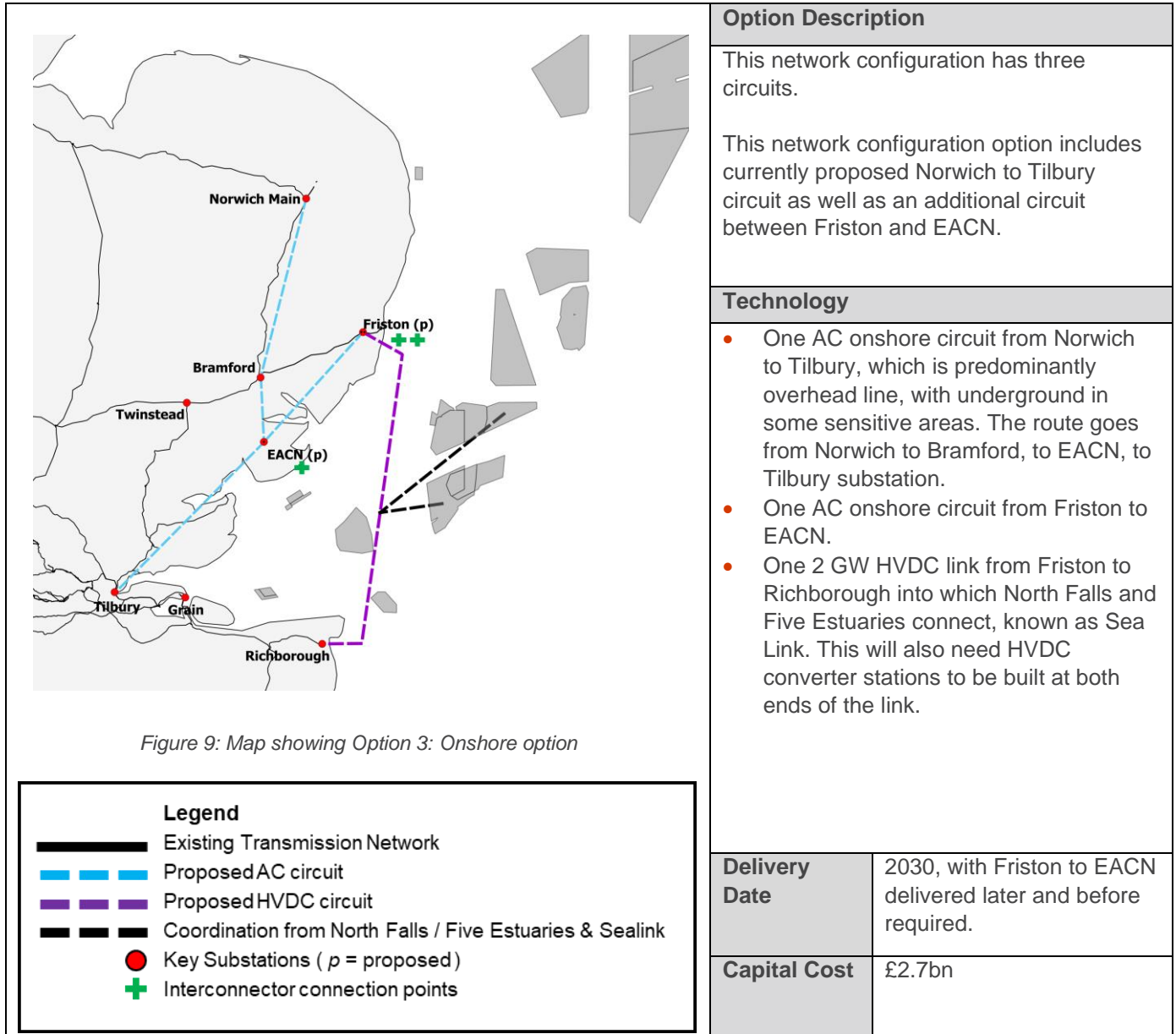

Option 3			
Design Criteria	Ranking	Sub Description	Commentary
Deliverability & Operability	Red	Supply chain, deliverability, and operability	Challenging delivery of multiple new onshore AC circuits. No additional HVDC so reduced HVDC supply difficulties. This would drive an Amber as significantly complex.
		Consenting	This option presents a highly complex consenting risk due to the large number of onshore routes required and impacts on multiple pinch points in the region such as especially around areas with a concentration of infrastructure such as Friston, and the impact on EACN and the Dedham Vale.

Option 3			
Design Criteria	Ranking	Sub Description	Commentary
Environmental	Amber	Friston to EACN to Tilbury (onshore)	<p>As an onshore route, the individual components receive individual Amber or (in one case) Green BRAG ratings. The spatial extent and distribution of the onshore constraints allows for potential avoidance, whereas a number of constraints in the marine environment are unavoidable.</p> <p>However, mitigation such as detailed route planning, should be able to reduce the impact on many of the significant onshore environmental constraints.</p> <p>An Amber rating means this option is moderately constrained; it is potentially viable however, will have to overcome some environmental issues.</p>
		Bramford to EACN (onshore)	
		Friston to Richborough (offshore)	
		Norwich to Bramford (onshore)	
Community	Red	Friston to EACN to Tilbury (onshore)	<p>Overall, this option is significantly constrained. A combination of the onshore works, and the widespread of community impact features, combined with the significant constraints identified between Bramford and EACN, means avoidance of key constraints would be difficult.</p> <p>In addition, undergrounding may need to be considered as a mitigation where avoidance was not possible.</p>
		Bramford to EACN (onshore)	
		Friston to Richborough (offshore)	
		Norwich to Bramford (onshore)	
Economic	Economic Rank	£0bn	<p>The option received a Green rating, being the cheapest over its lifetime compared to all other options if delivered in 2030.</p> <p>It has a relatively low capital cost, and is efficient at mitigating constraints from 2030, and it facilitates all interconnectors at their original locations.</p>
	Delay Impact	£1.6bn	<p>If this option cannot be delivered until 2034, then its lifetime cost is increased, as it does not mitigate constraints from 2030 onwards.</p> <p>A number of other options, if everything is delivered in 2034, move to having similar lifetime costs.</p>
Community Sentiment	Red	This option has new overhead lines – with visual impact spanning across three regions. Significant concentrated impact at proposed substations.	

4. Alternative onshore option – variation without Bramford to EACN

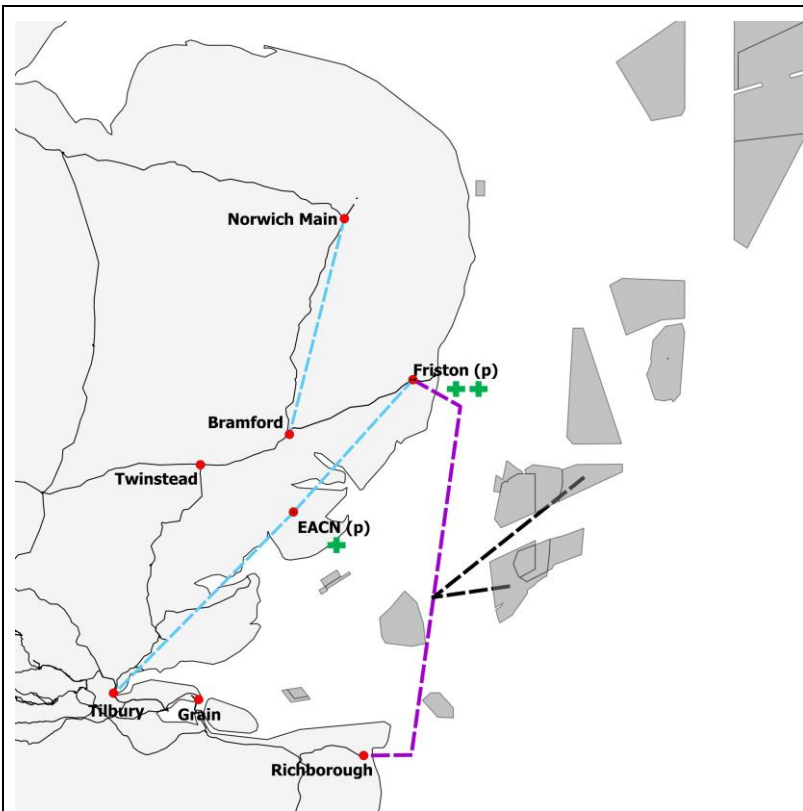

Figure 10: Map showing Option 4: Alternative onshore option - variation without Bramford to EACN

Legend	
	Existing Transmission Network
	Proposed AC circuit
	Proposed HVDC circuit
	Coordination from North Falls / Five Estuaries & Sealink
	Key Substations (p = proposed)
	Interconnector connection points

Option Description

This network configuration has three circuits. This configuration is similar to Option 3, but with the part of the Norwich to Tilbury route between Bramford and EACN removed.

Figure 10 on the left: Map showing Option 4: Alternative onshore option – variation with EACN

Technology

- One AC onshore circuit from Norwich to Bramford
- One AC onshore circuit from Friston to Tilbury, via EACN.
- One 2 GW HVDC link from Friston to Richborough into which North Falls and Five Estuaries connect, known as Sea Link. This will also need HVDC converter stations to be built at both ends of the link.

Delivery Date	2030, with Friston to EACN delivered later and before required.
----------------------	---

Capital Cost	£2.4bn
---------------------	--------

Option 4			
Design Criteria	Ranking	Sub Description	Commentary
Deliverability & Operability	Red	Supply chain, deliverability, and operability	This option has the same challenges as Option 3, but with a small section of onshore circuit through the Dedham Vale removed. This does not change the rating as remains significantly complex

Option 4			
Design Criteria	Ranking	Sub Description	Commentary
		Consenting	This option is assessed to have the same highly complex risk to consenting as Option 3, even with a small section of onshore circuit through the Dedham Vale removed. Overall, this is not sufficient to change the overall rating from Red.
Environmental	Amber	Friston to EACN to Tilbury (onshore)	This option is an onshore option. The individual components receive individual Amber or (in one case) Green BRAG ratings. This represents that many of the significant onshore and (where applicable) offshore environmental constraints should be avoided (or otherwise mitigated) at the detailed routeing stage. An Amber rating means this option is moderately constrained; it is potentially viable however, will have to overcome some environmental issues.
		Friston to Richborough (offshore)	
		Norwich to Bramford (onshore)	
Community	Amber	Friston to EACN to Tilbury (onshore)	This option comprises a balance of onshore and offshore study areas. Some consideration will need to be made to routeing including at the coastal interface point to avoid constraints where possible. While a number of features have been identified across study areas, these are generally distributed thinly across the areas, meaning detailed routeing could be feasible to avoid most constraints. This option is overall considered to be moderately constrained.
		Friston to Richborough (offshore)	
		Norwich to Bramford (onshore)	
Economic	Economic Rank	£2bn	The options received a Green rating costing £2bn more over its lifetime compared to the cheapest option (Option 3 delivered in 2030). It is one of the cheapest solutions, however, the removal of the circuit through the Dedham Vale reduces the effectiveness of this option at routeing power out of the region in comparison of Option 3, which increases the constraint cost.
	Delay Impact	£3.6bn	If this option cannot be delivered until 2034, then the benefits in reducing CAPEX it brings in the early years is lost, and other options move to the comparatively better.
Community Sentiment	Red		This option has new overhead lines – with visual impact spanning across three regions. Significant concentrated impact at proposed substations.

5. Alternative onshore option – variation without EACN

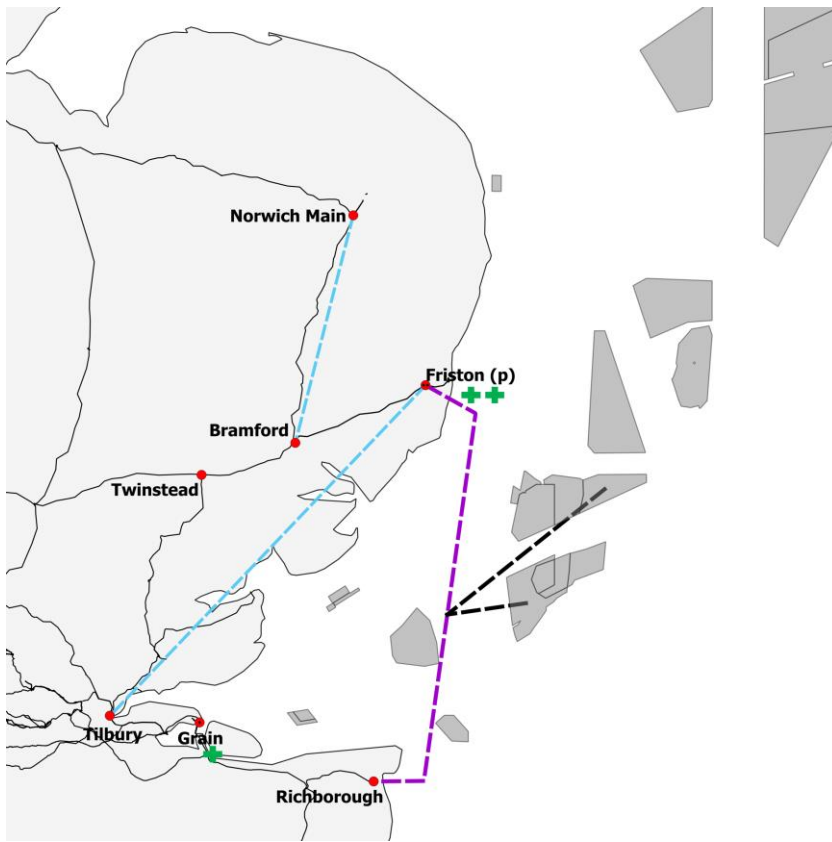

Figure 11: Map showing Option 5: Alternative onshore option – variation without EACN

Legend	
	Existing Transmission Network
	Proposed AC circuit
	Proposed HVDC circuit
	Coordination from North Falls / Five Estuaries & Sealink
	Key Substations (p = proposed)
	Interconnector connection points

Option Description

This network configuration has three circuits. This configuration is similar to Option 4, however the proposed substation at EACN is not required.

Therefore, the line does not need to route to the EACN, and can take a different route, although detailed routing is undertaken by National Grid Electricity Transmission (NGET) at a later stage in the design process.

Technology

- The Norwich to Bramford AC route which is predominantly overhead lines (this is the northern part of the proposed Norwich to Tilbury route).
- An AC route from Friston to Tilbury, which is predominantly overhead line (this includes the southern part of the Norwich to Tilbury route. Near the proposed EACN the route no longer needs to serve that substation so can be routed elsewhere).
- As well as Sea Link, the 2 GW HVDC link from Friston to Richborough into which North Falls and Five Estuaries connect. Converter stations will be required at both ends of Sea Link.

Delivery Date	2034 (the components such as Norwich to Bramford and Friston to Richborough could be delivered earlier)
Capital Cost	£2.3bn

Option 5			
Design Criteria	Ranking	Sub Description	Commentary

Deliverability & Operability	Amber	Supply chain, deliverability, and operability	Similarly to Option 3 and 4, this onshore option has the same challenges, although without the section of circuit through the Dedham Vale, and the rerouting of the circuit as it does not need to go via the Tendering peninsula for EACN. This does make it comparatively simpler as few components need to be delivered.
		Consenting	Overall, the position is similar to Options 3 and 4, but with the removal of two of the areas of high complexity of consenting at the Dedham Vale and EACN. Significant complexity remains both onshore especially at areas such the concentration of infrastructure at Friston, but overall this leads to an Amber RAG rating.
Environmental	Amber	Friston to Tilbury (onshore)	<p>This option is a variation of Option 4 comprising both onshore and offshore areas. As EACN does not feature in this option, the assessment can be considered without the impact of EACN. Overall although avoiding the Tendring Peninsula reduces the impact there, the line still needs to be routed in the vicinity, affecting other similar areas. As the overall rating is still driven by the Amber ratings of two components, this option is assessed as Amber.</p> <p>An Amber rating means this option is moderately constrained, it is potentially viable however, will have to overcome some environmental issues.</p>
		Friston to Richborough (offshore)	
		Norwich to Bramford (onshore)	
Community	Amber	Friston to Tilbury (onshore)	<p>This option comprises a balance of onshore and offshore study areas. Some consideration will need to be made to routeing including at the coastal interface point to avoid constraints where possible. While a number of features have been identified across study areas, these are generally thinly distributed across the areas, meaning detailed routeing could be feasible to avoid most constraints.</p> <p>This option is overall considered to be moderately constrained. This option does not include EACN. While its inclusion could result in some reduced localised impact it, is not considered to materially impact the cumulative rating and so the option remains moderately constrained.</p>
		Friston to Richborough (offshore)	
		Norwich to Bramford (onshore)	
Economic	Economic Rank	£10.3bn	<p>The options received a Red rating costing £10.3bn more over its lifetime compared to the cheapest option (Option 3 delivered in 2030).</p> <p>Although this option is the cheapest option the removal of the circuit through the Dedham Vale, together with moving an Interconnector to Grain reduces the effectiveness of this option at routeing power. Significant constraints are caused moving power to the interconnector in Kent for power to be exported.</p>
	Delay Impact	£10.3bn	There is no change in the relative economic position of this option if all options are considered delivered in 2034.
Community Sentiment	Red	This option has new overhead lines – with visual impact spanning across three regions. Significant concentrated impact at proposed substations.	

Option 5b. Alternative onshore option – variation without EACN – sensitivity

Following a stakeholder request, we explored the high constraint cost results in Option 5 (an alternative onshore option without Bramford to the EACN and without EACN substation) and why it compares economically worse to other options, including Option 4.

As Britain moves from being a net importer to a net exporter of electricity over the coming years and builds out more and more renewable generation, interconnectors to neighbouring countries help a region with a high level of low carbon generation compared to demand. Therefore, in a region such as East Anglia with a high volume of proposed wind generation connected, proposed interconnectors in the region export power from the region at times of high wind and low energy prices to other countries and hence this power does not need to flow across the network and out of the region. Whereas, if an interconnector is located elsewhere in Britain, the power would first need to leave East Anglia and traverse the network to reach the interconnector.

In Option 5, a scenario without Bramford to EACN, two interconnectors are modelled at Friston, and one at the Isle of Grain. Grain has been chosen as we are aware an interconnector is exploring connecting there. This means less interconnector export capability from East Anglia. This is also a common setup in other options, for the predominantly offshore (Option 1) and hybrid option (Option 7) without EACN.

Under Option 5, with an interconnector at Grain, at times of high wind / low prices, power must leave the East Anglian region and traverse the network in the southeast to Grain to be exported, rather than being exported directly, as is the case in Option 4. This means that at times the export capacity from East Anglia is not sufficient and capacity in the southeast is already limited at times. Therefore, we see this manifest as an increase in constraint costs, both to manage the power flows exiting East Anglia, as well as potentially limiting the flows of power into the Southeast.

Comparing Option 5 to other options with an interconnector at Grain

We do not see a similar magnitude in constraint costs under Options 1 and 7, which have the same interconnector configuration. This is because of the circuits which form part of Options 1 and 7 to move power out of the East Anglia region. In these two options, there is a new HVDC subsea 2 x 2GW circuit from Norwich to Grain. This moves power directly from Norwich to Grain. This means that excess power from the region can be moved 'directly' to the point of interconnection – without needing to traverse the constrained network in the southeast.

Sensitivity Analysis

The ESO hypothesised with stakeholders that to reduce the cost of constraints within option 5 there could be two primary solutions:

- Reinforce the electricity network (via overhead lines) between Tilbury in Essex and Grain in Kent, or within Kent itself. Short overhead lines could have a relatively cheaper capital costs to build compared with the system constraint costs accrued within this option (both of which are paid for by energy bill payers). However, they would result in additional onshore circuits proposed in Kent.
- Change the interconnector location from Grain to behind the EC5 electrical boundary encompassing East Anglia within the model, moving all three interconnectors back into the region – with two at Friston and one (nominally) at Bramford.

The ESO have modelled the change in interconnector location, the result of our assessment was that this sensitivity changed the economics of this option, but all other metric results stayed the same as shown below.

Economic	Economic Rank	£1.4bn	The option receives a Green rating costing £1.4bn more over its lifetime compared to the cheapest option (Option 3 delivered in 2030). Moving the interconnector to (nominally) Bramford removes the high constraint costs seen in Option 5.
	Delay Impact	£1.4bn	If other options cannot be delivered until 2034, then this option moves to having a similar lifetime cost to the cheapest options.

This sensitivity analysis also demonstrates the important role that interconnectors play in the region in exporting excess electricity and supporting in managing in constraints.

6. Hybrid onshore and offshore option

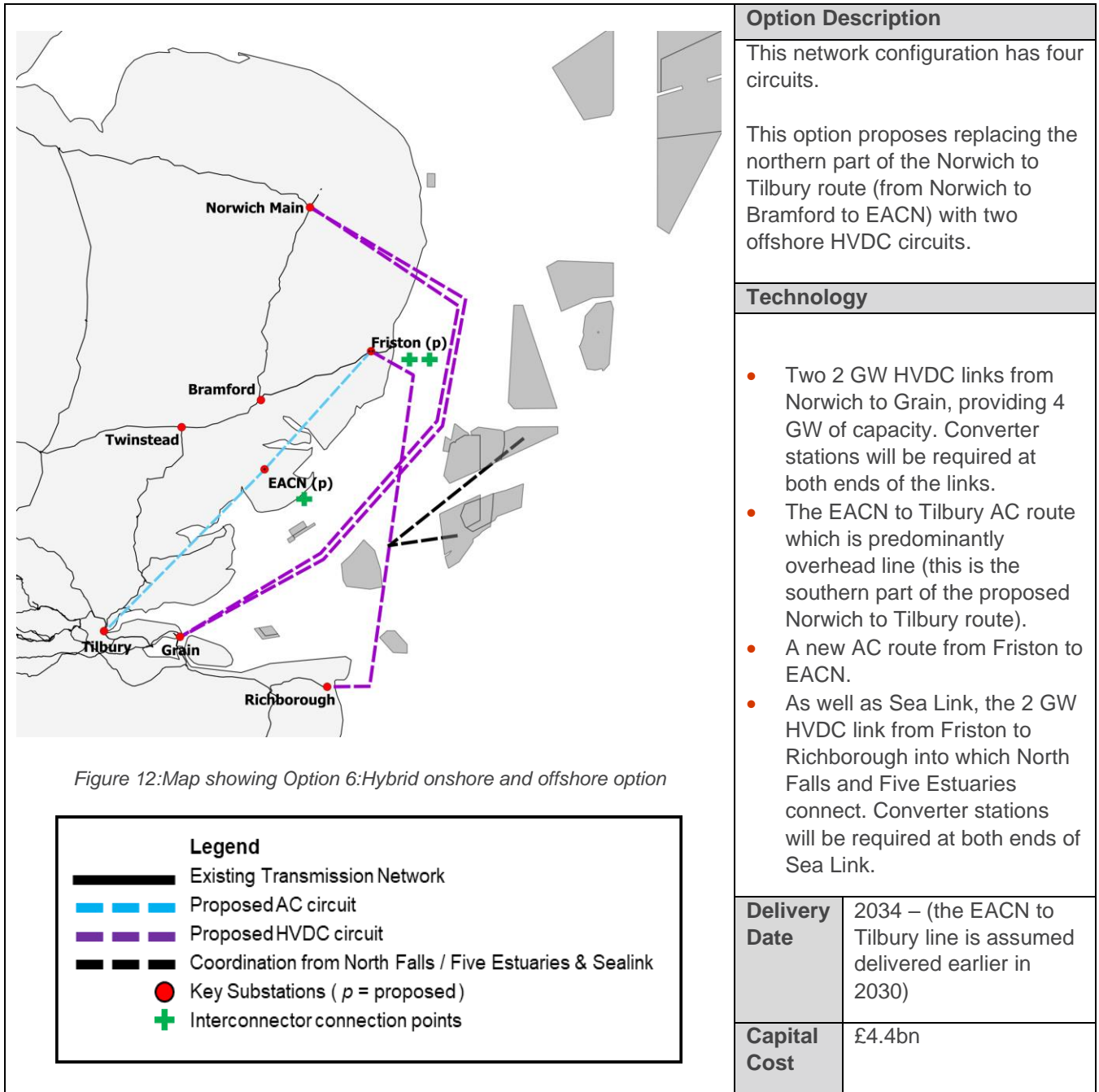

Option 6			
Design Criteria	Ranking	Sub Description	Commentary
Deliverability & Operability	Red	Supply chain, deliverability, and operability	The single additional HVDC may add some delay but less than the options with multiple additional HVDC. Limited suppliers of HVDC and known supply chain delays.

Option 6			
Design Criteria	Ranking	Sub Description	Commentary
		Consenting	As a blend of onshore and offshore, this solution has a highly complex risk to consenting. The option includes a concentration of infrastructure at Friston, and the East Anglia Connection Node. The HVDC route in this option also need to pass from Norwich to the coast (in the vicinity of The Broads) which is likely to add to the complexity of consenting. This drives the Red rating.
Environmental	Red	Friston to EACN to Tilbury (onshore)	This option includes the heavily constrained component from Norwich to Grain, with its impact on the onshore environment in Norfolk and the complex marine environment offshore. As Norwich to Grain is a key part of this option, overall the option is assessed to be Red. A Red rating means this option is heavily constrained, it is potentially viable however, will have to overcome many environmental issues.
		Norwich to Grain (offshore)	
		Friston to Richborough (offshore)	
Community	Amber	Friston to EACN to Tilbury (onshore)	This option comprises two study areas in the marine environment with moderate constraint. Consideration will need to be given to coastal interface locations and routeing to avoid and minimise impact where possible. The onshore study area includes a number of constraints which are distributed across the study area, meaning with detailed routeing it could be feasible to avoid most constraints. This option is overall considered to be moderately constrained.
		Norwich to Grain (offshore)	
		Friston to Richborough (offshore)	
Economic	Economic Rank	£1.7bn	The options received a Green rating costing £1.7bn more over its lifetime compared to the cheapest option (Option 3 delivered in 2030). This option is delivered in full by 2034. It is a 'middle cost' options driven by the cost of converter stations and HVDC subsea cabling, and the onshore route. It is effective at reducing constraints, and the route from Norwich to Grain performs well at moving power from the region.
	Delay Impact	£2.1bn	If some of the onshore elements of this option are delivered late, then some of that initial benefit is lost. This means that it moves slightly comparative economic ranking if everything is delayed, but it still have a comparatively similar lifetime cost to the cheapest options.
Community Sentiment	Red	This option has a mixture of new overhead lines and subsea cables with visual impact spanning across three regions. Significant concentrated impact at proposed substations.	

7. Hybrid onshore and offshore option – variation without EACN

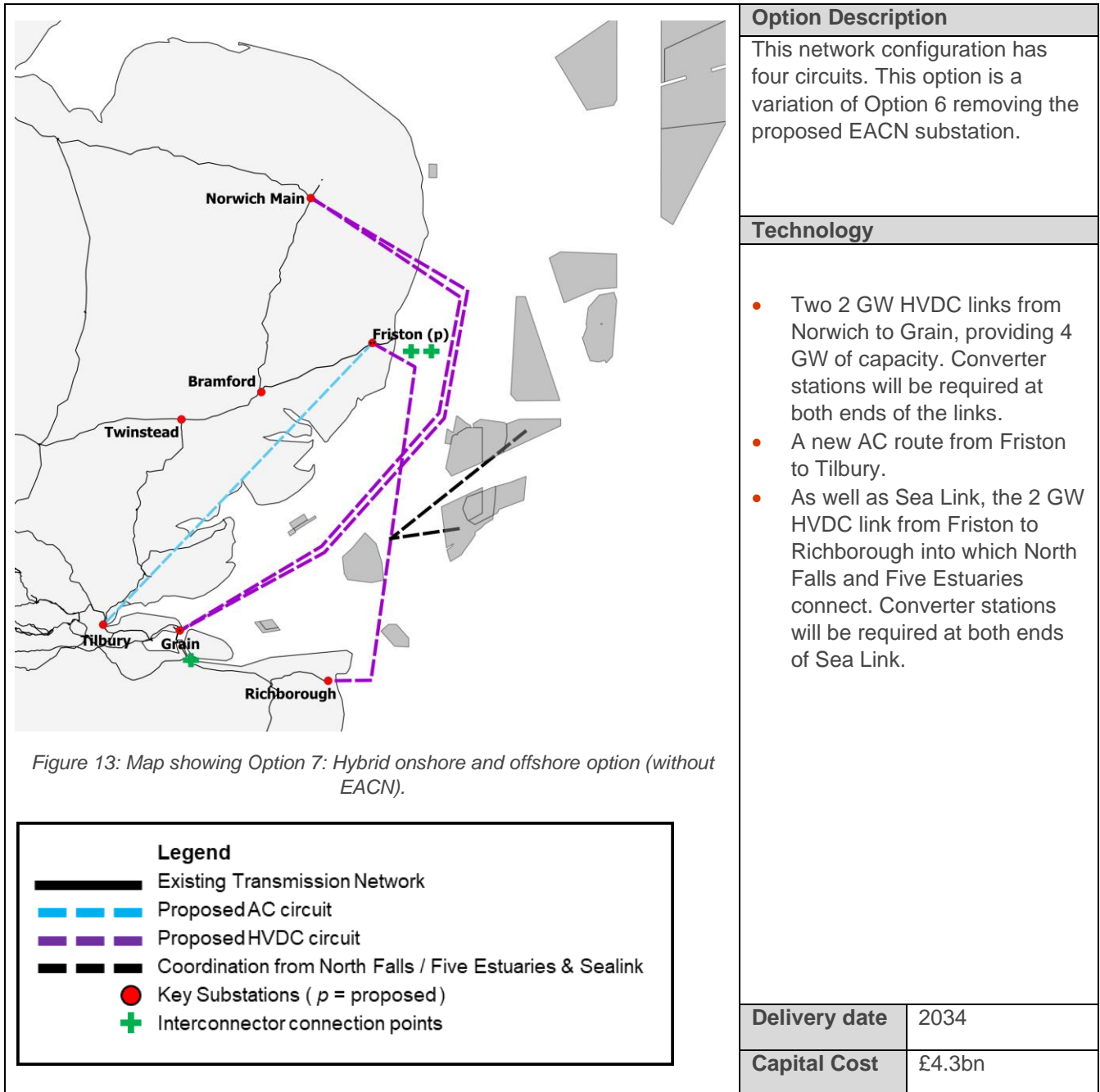

Figure 13: Map showing Option 7: Hybrid onshore and offshore option (without EACN).

Option 7			
Design Criteria	Ranking	Sub Description	Commentary
Deliverability & Operability	Amber	Supply chain, deliverability, and operability	The single additional HVDC may add some delay but less than the options with multiple additional HVDC. Limited suppliers of HVDC and known supply chain delays.
		Consenting	This option is assessed to be a significantly complex risk to consenting; although and southern onshore route and

			<p>a Norwich to Grain offshore route remains, the option does not include the EACN or a route through the from Bramford through the Dedham Vale.</p> <p>There are still significant complexities in consenting this option, including concentration of infrastructure at Friston.</p>
Environmental	Red	Friston to Richborough (offshore)	<p>As EACN does not feature in this option, the assessment for the Friston to Tilbury component can be considered without the impact of EACN. Overall, although avoiding the Tendring Peninsula reduces the impact in that location, the line still needs to be routed in the vicinity, potentially affecting other similar areas.</p>
		Norwich to Grain (offshore)	<p>This option includes the heavily constrained component from Norwich to Grain, with its impact on the onshore environment in Norfolk and the complex marine environment offshore. As Norwich to Grain is a key part of this option, overall the option is assessed to be Red.</p>
		Friston to Tilbury (onshore)	<p>A Red rating means this option is heavily constrained, it is potentially viable however, will have to overcome many environmental issues.</p>
Community	Amber	<p>Friston to Richborough (offshore)</p> <p>Norwich to Grain (offshore)</p> <p>Friston to Tilbury (onshore)</p>	<p>This option comprises two study areas in the marine environment with moderate constraint. Consideration will need to be given to coastal interface locations and routing to avoid and minimise impact where possible. The onshore study area consists of several constraints which are distributed throughout. It should be feasible to avoid most constraints with detailed routing. This option is overall considered to be moderately constrained. While this option does not include EACN - which may result in some reduced localised impact - it is not considered to materially impact the cumulative rating and so the option remains moderately constrained.</p>
Economic	Economic Rank	£1.8bn	<p>The options received a Green costing £1.8bn more over its lifetime compared to the cheapest option (Option 3 delivered in 2030).</p> <p>This option is delivered in full by 2034. It is a middle cost expensive driven by the cost of converter stations and HVDC subsea cabling, and the onshore route. It is effective at reducing constraints, and the route from Norwich to Grain performs well at moving power from the region including to the interconnector located at Grain.</p>
	Delay Sensitivity	£1.8bn	<p>If all options are delayed, then this option has a comparatively similar cost of a number of the other cheapest options.</p>
Community Sentiment	Red	<p>This option has a mixture of new overhead lines and subsea cables with visual impact spanning across three regions. Significant concentrated impact at proposed substations.</p>	

8. An onshore HVDC route

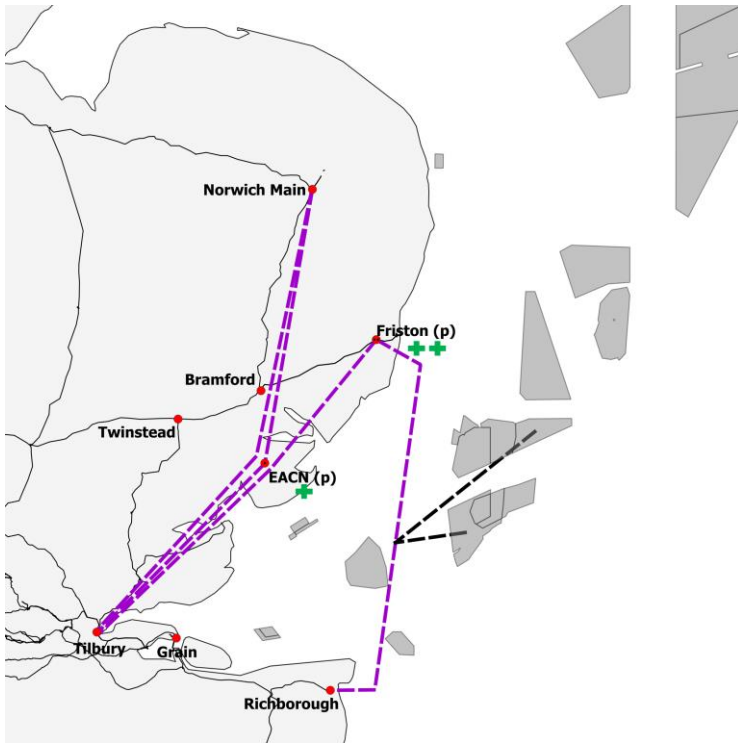

Figure 14: Map showing Option 8: Onshore HVDC option

Legend	
	Existing Transmission Network
	Proposed AC circuit
	Proposed HVDC circuit
	Coordination from North Falls / Five Estuaries & Sealink
	Key Substations (p = proposed)
	Interconnector connection points

Option Description	
<p>This network configuration has three routes across and out of East Anglia, comprising of three circuits. This option replaces the onshore network configuration with an equivalent undergrounded HVDC route.</p>	
Technology	
<ul style="list-style-type: none"> • A 2 GW undergrounded HVDC line from Friston to Tilbury, bypassing the EACN. • A 2 GW undergrounded HVDC three-ended line, from Norwich to EACN to Tilbury. This would have a 'T point' to connect the interconnector at EACN, but it would not be a full substation. • In addition to Sea Link, the 2 GW HVDC link from Friston to Richborough into which North Falls and Five Estuaries connect. • In this region there would be two converter stations at Norwich, one at Friston, and three at Tilbury. EACN would receive a 't-point' connection the DC interconnector. 	
Delivery Date	2034 (with Sea Link delivered earlier)
Capital Cost	£4.9bn

Option 8			
Holistic Network Design Criteria	Assessment Ranking	Sub Description	Commentary
Deliverability & Operability	Red	Supply chain, deliverability, and operability	Challenging delivery with multiple HVDC circuits. Limited suppliers of HVDC and known supply chain delays. A solution of this nature and scale has never been delivered in Great Britain which increases the risk.

Option 8			
Holistic Network Design Criteria	Assessment Ranking	Sub Description	Commentary
		Consenting	This option, while onshore, results in an undergrounded solution so less long-term visual impact, except at the ends of the circuits with the placement of convertor station. Significant HVDC converter stations will be needed at the ends of the routes – Norwich, EACN, Friston and Tilbury. This is likely to present a significant complexity to consenting.
Environmental	Amber	Friston to Tilbury (HVDC onshore) Friston to Richborough (offshore) Bramford to EACN (HVDC onshore) Norwich to Bramford (HVDC onshore)	<p>In this option, similar routes to Option 3 are used onshore, but all the circuits are now underground.</p> <p>Overall this does not affect the environmental score of the options. As whilst the potential for environmental impact for this underground route is greater during the construction phase. once complete (and with the addition of appropriate mitigation) the long term impact should be significantly reduced. This would be of particular relevance to the Dedham Vale area. Whilst offshore a number of constraints would be unavoidable due to their significant size and location. Overall, on balance, this option remains an Amber rating.</p> <p>An Amber rating means this option is moderately constrained, it is potentially viable however, it will have to overcome numerous environmental issues.</p>
Community	Amber	Friston Tilbury (onshore HVDC) Friston to Richborough (offshore) Bramford to EACN (onshore HVDC) Norwich to Bramford (onshore HVDC)	This option consists of study areas predominantly onshore with one area offshore. Despite the significant constraints identified between Bramford and EACN, combination of the options is overall considered to be moderately constrained. The other study areas have several constraints spread widely throughout these locations. This means overall detailed routeing would be needed to avoid constraints where possible. This option mitigates some of the constraints by placing the routes underground rather than overhead, and whilst this has the potential to cause significant impact during construction, the enduring impact is reduced.
Economic	Economic Rank	£1bn	<p>The options received a Green rating costing £1bn more over its lifetime compared to the cheapest option (Option 3 delivered in 2030).</p> <p>This option although at the higher cost, and delayed, performs well over its lifetime.</p>

Option 8			
Holistic Network Design Criteria	Assessment Ranking	Sub Description	Commentary
	Delay Impact	£1bn	If other options are delayed until 2034, then this option comes into closer comparison to other options, showing itself overall, to be the lowest cost option in the delay situation.
Community Sentiment	Amber	Onshore routes but undergrounded are view more favourably. Still significant impact at Friston, EACN, Norwich and Tilbury for converter stations.	

9. Predominantly offshore option – utilising Bradwell as a landing point

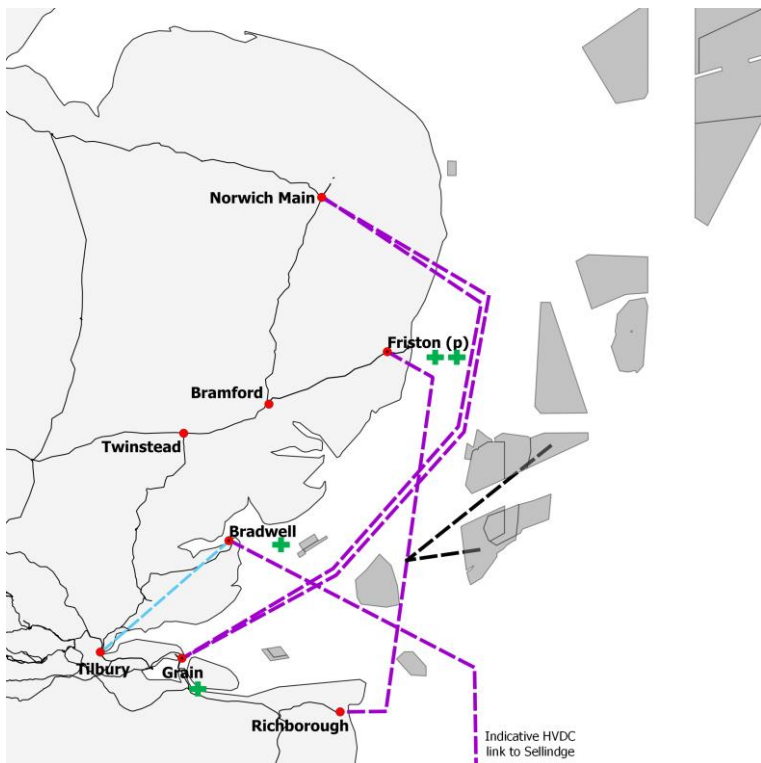

Figure 15: Map showing Option 9: Predominantly Offshore Option utilising Bradwell

Legend	
	Existing Transmission Network
	Proposed AC circuit
	Proposed HVDC circuit
	Coordination from North Falls / Five Estuaries & Sealink
	Key Substations (p = proposed)
	Interconnector connection points

Option Description

This network configuration has three routes out of East Anglia, comprising of four circuits. These circuits would begin at Norwich, Fiston and Bradwell and will be undergrounded to the coast and continue offshore in the sea to three onshore locations in Kent - Grain, Richborough and (nominally) Sellindge. There is uprating required at Bradwell to Rayleigh.

This configuration is a variation of Option 1 and explores using Bradwell as a landing point for an HVDC cable, to remove power from the wider region and negate the need for additional infrastructure at Fiston.

Technology

- Two 2 GW HVDC links from Norwich to Grain, providing 4 GW of capacity with HVDC converter stations to be built at both ends of the link.
- One 2 GW HVDC link from Fiston to Richborough into which North Falls and Five Estuaries connect, known as Sea Link. This will also need HVDC converter stations to be built at both ends of the link.
- A 2 GW HVDC link from Bradwell to (nominally) Sellindge with HVDC converter stations to be built at both ends of the link.
- A 400 kV Overhead line replacing the existing 132 kV route from Bradwell to Rayleigh substation.

Delivery Date	2034 (with Sea Link delivered earlier)
Capital cost	£5.2m

Option 9			
Design Criteria	Ranking	Sub Description	Commentary
Deliverability & Operability	Black	Supply chain, deliverability, and operability	<p>Challenging delivery with multiple HVDC circuits. Limited suppliers of HVDC and known supply chain delays. The options have a limitation on export capacity from Friston, which means either less generation or a further route of Friston is required (see below). This is driving the Black rating.</p> <p>This option is notable as the one option, which has a black rating for one of the metrics, specifically Deliverability. This is because the network under this option does not have sufficient capacity for export out of Friston under the fault condition as discussion in assumption on page 23, and this was a specific design choice to avoid putting additional infrastructure at Friston.</p> <p>This black rating for deliverability could be mitigated in two ways – either less generation connects at Friston than is expected, or additional network is built out of Friston. As an example of the additional network required, a further 2GW HVDC line from Friston to Bradwell would cost around £900m in capital costs but would reduce the total lifetime cost from £9bn to around £6.2bn.</p>
		Consenting	The solution is predominantly offshore and removes one link out of an area with a concentration of infrastructure at Friston. Overall, it still presents a significant complexity, especially around areas with a concentration of infrastructure such as Friston.
Environmental	Red	Norwich to Grain (offshore)	<p>This option reduces the number of HVDC lines landing at Friston, and instead uses Bradwell. It still has the heavily constrained Norwich to Grain route, and now gains a complex marine environment at Bradwell which identifies many overlapping significant constraints such as MCZs, SACs, SPAs, RAMSARs and SSSIs. The impacts of these cannot be mitigated by avoidance measures. Overall, this option is assessed as Red.</p> <p>A Red rating means this option is heavily constrained, it is potentially viable however, will have to overcome many environmental issues.</p>
		Friston to Richborough (offshore)	
		Bradwell to Sellindge (offshore)	
		Bradwell to Rayleigh (onshore)	
Community	Amber	Norwich to Grain (offshore)	<p>This option reduces the number of HVDC lines landing at Friston and instead uses Bradwell. Due to the number of coastal interface locations, consideration will need to be given to routing and landfall locations to avoid and minimise impact where possible. The onshore study area consists of a number of constraints including National Landscapes.</p> <p>While further community features have been identified across the study area, these are generally thinly distributed, meaning</p>
		Friston to Richborough (offshore)	
		Bradwell to Sellindge (offshore)	

Option 9			
Design Criteria	Ranking	Sub Description	Commentary
		Bradwell to Rayleigh (onshore)	detailed routeing should be feasible to avoid most constraints. This option is overall considered to be moderately constrained.
Economic	Economic Rank	£9bn	The options received a Red rating costing £9bn more over its lifetime compared to the cheapest option (Option 3 delivered in 2030). This option has one of the highest capital costs, and performs poorly at removing power from the East Anglia region, as the connection from Bradwell to Kent is outside where the majority of the power is being generated and connected.
	Delay Impact	£9bn	There is no change in the relative economic position of this option if all options are considered delivered in 2034.
Community Sentiment	Amber	This option involves an uprating of an existing overhead line which could have a visual impact; however, it has significant concentrated impact at proposed coastal nodes.	

7. Summary of results

The ratings from the options assessment tables in the previous section are summarised below. A rating is given for each option and for each of the holistic design criteria.

	Option description	Delivery date	Deliverability and operability ranking	Environmental ranking	Community ranking	Economic rating (on-time delivery)	Economic rating (2034 Delivery)
1	Predominately offshore option – variation without East Anglia Connection Node (EACN)	2034	Red	Red	Amber	£4.2 bn	£4.2 bn
2	Predominately offshore option – variation with EACN	2034	Red	Red	Red	£4.8 bn	£4.8 bn
3	Onshore option	2030	Red	Amber	Red	£0 bn	£1.6 bn
4	Alternative Onshore option – variation with EACN	2030	Red	Amber	Amber	£2.0 bn	£3.6 bn
5	Alternative Onshore option – variation without Bramford to EACN	2034	Amber	Amber	Amber	£10.3 bn	£10.3 bn
5b	Alternative Onshore option – variation without Bramford to EACN – sensitivity	2034	Amber	Amber	Amber	£1.4 bn	£1.4 bn
6	Hybrid onshore and offshore option – variation with EACN	2034 ⁴¹	Red	Red	Amber	£1.7 bn	£2.1 bn
7	Hybrid onshore and offshore option – variation without EACN	2034	Amber	Red	Amber	£1.8 bn	£1.8 bn
8	Onshore HVDC Option	2034	Red	Amber	Amber	£1.0 bn	£1.0 bn
9	Using Bradwell as a landing point	2034	Black	Red	Amber	£9.0 bn	£9.0 bn

Table 7: Summary of options assessment

Community sentiment

The community sentiment for each option is summarised below.

Option Number	Option description	Community sentiment
1	Predominately offshore option (without East Anglia Connection Node (EACN))	Amber
2	Predominately offshore option (with EACN)	Red
3	Onshore option (closest to status quo)	Red
4	Alternative Onshore option – variation with EACN	Red
5	Alternative Onshore option – variation without EACN	Red
5b	Alternative onshore option – variation without EACN – sensitivity	Red
6	Hybrid onshore and offshore option (with EACN)	Red
7	Hybrid onshore and offshore option (without EACN)	Red
8	Onshore HVDC Option	Amber

⁴¹ *Elements of the hybrid option 6 can be delivered in 2030, although the full solution would not be delivered until 2034, so it has a variation in the delay case.

Option Number	Option description	Community sentiment
9	Using Bradwell as a landing point	Amber

Table 8: Summary of community sentiment

Conclusions

To transfer the energy being generated in the region and off its shores, there have been several network reinforcements proposed by the relevant Transmission Owner. This spans from upgrading existing circuits, reinforcing the Bramford to Twinstead onshore circuit as well as a new onshore circuit proposed from Norwich to Tilbury.

The new power flows brought on by the potential change in connection location stemming from the OCSS, has meant that new network configuration options are available for the Transmission Owner to consider should OCSS continue. However, these options assessed within this study come with critical trade-offs to be made.

The ESO have holistically assessed ten network configuration options in East Anglia using the OCSS outcome as our baseline. Six options were developed by the ESO and NGET and four were proposed by community representatives. These network configuration options range from onshore network configurations to a network configuration involving no new overhead lines within East Anglia.

What is evident is there is no single option that minimises impacts across all the metrics. Critical trade-offs will need to be made between the cost borne by consumers, communities hosting this nationally significant infrastructure as well as environmental considerations.

Economic:

Our economic analysis compares the cost of moving power around the system posed by each option compared to its capital cost. The capital cost and the cost of managing a lack of capacity in the system is borne by bill payers.

When combined with overall system impact, the onshore option ranks highest as it is deliverable earlier (in 2030), however if a later delivery of 2034 is assumed then the undergrounded HVDC option as well as hybrid onshore and offshore options are comparable in ranking.

The options under assessment have been benchmarked against European (Scottish and equivalent schemes in Great Britain). The offshore options utilising HVDC technology and onshore AC technology are within the price range that we would expect. Further information on this benchmarking and additional economic sensitivities undertaken can be found in our appendix.

Environmental:

In general, all options under assessment face environmental constraints. Some of the offshore circuits present more challenges due to the complexity of the marine environment. Bradwell is particularly environmentally challenging as a landing point for offshore cables compared with other landing points within the study. This is because Bradwell has more overlapping sites of international designation than other proposed landing points.

Community:

Typically, more communities are impacted by onshore network configurations within this assessment than offshore options. To reflect the sentiment when engaging with local elected officials, we have scored each option against community sentiment, reflecting that our community metric is high level and uses geo-spatial data.

Most of the network options result in areas with a concentration of infrastructure (substation, converter station and associated overhead lines or underground cabling) at key proposed nodes along the coast. This is likely to have significant cumulative impact in these areas.

Deliverability:

While all technology faces supply chain issues, HVDC circuits face supply chain issues due to limited suppliers and global demand for this technology. This means that options with multiple offshore HVDC circuits are more challenging to deliver.

Next steps

This assessment has set out a side-by-side comparison of different electricity network configurations that transfer electricity across or around the region. Following this publication, we expect NGET to consider the assessment findings as part of their ongoing development of the Norwich to Tilbury circuit route.

We also shortly expect the UK Government and relevant OCSS developers to decide upon their progression to the next stage of the OCSS. We hope that this study provides all stakeholders with a range of options that could meet the network capacity needs of the region.

IET paper

A Comparison of Electricity Transmission Technologies: Costs and Characteristics

An independent report by Mott MacDonald
in conjunction with the IET



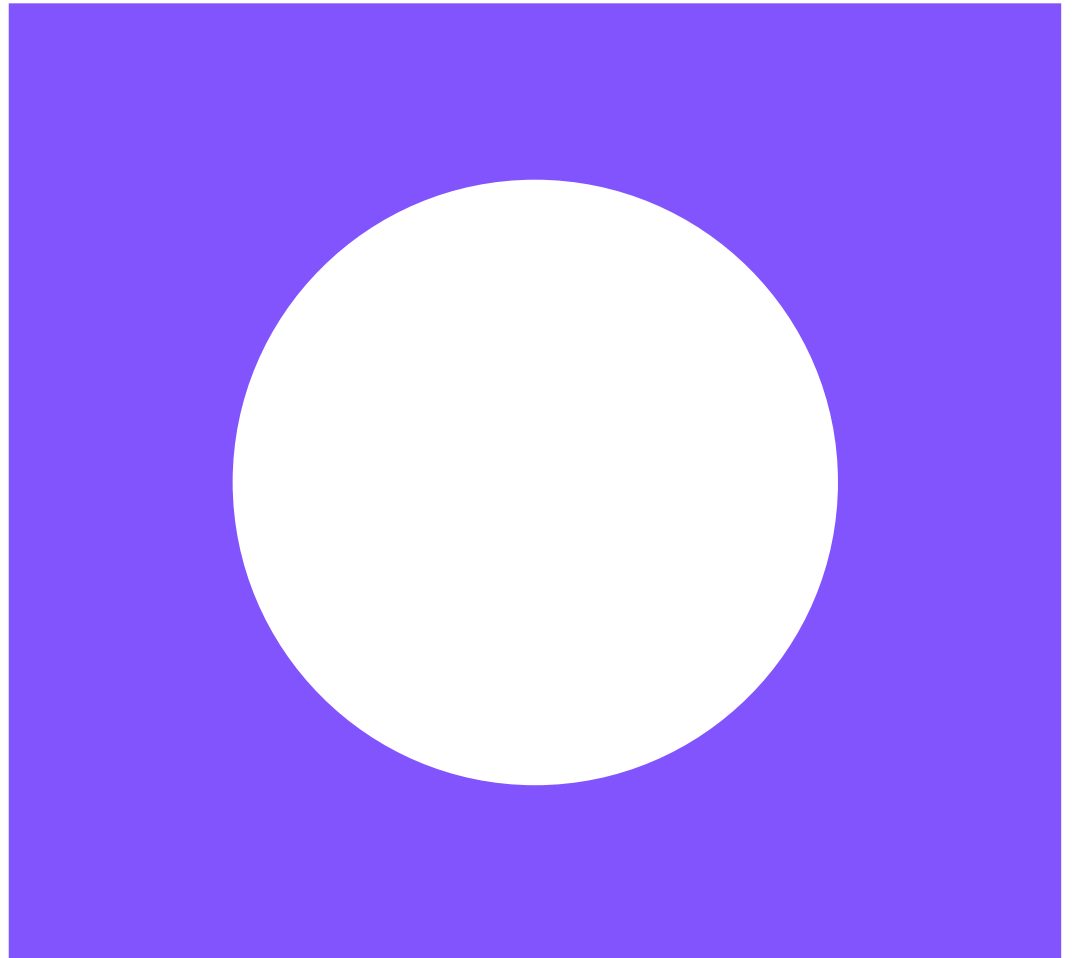

A Comparison of Electricity Transmission Technologies: Costs and Characteristics

An Independent Report by Mott MacDonald in
Conjunction with the IET

April 2025

This page left intentionally blank for pagination.

Victory House
Trafalgar Place
Brighton BN1 4FY
United Kingdom

T +44 (0)1273 365000
mottmac.com

A Comparison of Electricity Transmission Technologies: Costs and Characteristics

An Independent Report by Mott MacDonald in
Conjunction with the IET

April 2025

Issue and Revision Record

Revision	Date	Originator	Checker	Approver	Description
A	13/10/23				First issue
B	17/11/23				Updated in line with comments
C	05/12/23				Updated in line with comments
D	13/12/23				Updated in line with comments
E	08/11/24				Updated in line with comments, adjustments to non-cost characteristics aspects
F	19/12/24				Updated in line with comments
G	30/01/25				Updated in line with comments
H	14/02/25				Minor typographical adjustments, addition of MP Foreword
I	28/02/25				Minor adjustments
J	28/04/25				Minor adjustments

Document reference: 100110238 | 001 | J

This Report has been prepared solely for use by the party which commissioned it (the 'Client') in connection with the captioned project. It should not be used for any other purpose. No person other than the Client or any party who has expressly agreed terms of reliance with us (the 'Recipient(s)') may rely on the content, information or any views expressed in the Report. This Report is confidential and contains proprietary intellectual property and we accept no duty of care, responsibility or liability to any other recipient of this Report. No representation, warranty or undertaking, express or implied, is made and no responsibility or liability is accepted by us to any party other than the Client or any Recipient(s), as to the accuracy or completeness of the information contained in this Report. For the avoidance of doubt this Report does not in any way purport to include any legal, insurance or financial advice or opinion.

We disclaim all and any liability whether arising in tort, contract or otherwise which we might otherwise have to any party other than the Client or the Recipient(s), in respect of this Report, or any information contained in it. We accept no responsibility for any error or omission in the Report which is due to an error or omission in data, information or statements supplied to us by other parties including the Client (the 'Data'). We have not independently verified the Data or otherwise examined it to determine the accuracy, completeness, sufficiency for any purpose or feasibility for any particular outcome including financial.

Forecasts presented in this document were prepared using the Data and the Report is dependent or based on the Data. Inevitably, some of the assumptions used to develop the forecasts will not be realised and unanticipated events and circumstances may occur. Consequently, we do not guarantee or warrant the conclusions contained in the Report as there are likely to be differences between the forecasts and the actual results and those differences may be material. While we consider that the information and opinions given in this Report are sound all parties must rely on their own skill and judgement when making use of it.

Information and opinions are current only as of the date of the Report and we accept no responsibility for updating such information or opinion. It should, therefore, not be assumed that any such information or opinion continues to be accurate subsequent to the date of the Report. Under no circumstances may this Report or any extract or summary thereof be used in connection with any public or private securities offering including any related memorandum or prospectus for any securities offering or stock exchange listing or announcement.

By acceptance of this Report you agree to be bound by this disclaimer. This disclaimer and any issues, disputes or claims arising out of or in connection with it (whether contractual or non-contractual in nature such as claims in tort, from breach of statute or regulation or otherwise) shall be governed by, and construed in accordance with, the laws of England and Wales to the exclusion of all conflict of laws principles and rules. All disputes or claims arising out of or relating to this disclaimer shall be subject to the exclusive jurisdiction of the English and Welsh courts to which the parties irrevocably submit.

Contents

Foreword by the IET	1
MP Foreword	4
Use and Limitations of Report	5
Executive summary	6
1 Introduction	9
1.1 Introduction to the Report	9
1.2 Purpose of Report	9
1.3 Presentation and Structure of Report	10
1.4 Acknowledgements	10
2 Electricity Transmission in Great Britain	12
2.1 Background to GB Electricity Transmission	12
2.2 Pathway to 2030 – key points of reference	15
2.2.1 Development of the GB electricity system	15
2.2.2 Development of the transmission system	16
2.2.3 Delivery of new transmission system infrastructure	16
2.3 Network Planning Considerations and Challenges	16
2.4 GB Electricity Transmission Supply Chain	22
3 Scope and Methodology	25
3.1 Scope of Report	25
3.2 Technologies and Ratings	25
3.3 Overall Approach	31
3.4 Data Capture and Engagement with Supply Chain, Transmission Owners and System Operator	32
4 Cost and Ratings Assessment	35
4.1 Introduction	35
4.2 Presentation of Data	37
4.3 Whole Life Cost Assessments	38
4.4 Indicative Capital Expenditure Estimates	110
4.5 Cost and Ratings Assessment Conclusions	110
4.5.1 Conclusions for Onshore Technologies	110
4.5.2 Conclusions for Offshore Technologies	118
5 Discussion of Cost and Non-Cost Characteristics	123
5.1 Comparison With 2012 Report	143

6	Main Findings	146
	Appendices	150
A.	Terms of Reference	151
A.1	Background	151
A.2	Introduction	153
A.3	Scope, Assumptions and Exclusions	153
A.4	Methodology	157
A.5	Output	161
B.	Consultant Team Members	162
C.	Costing Methodology	163
C.1	Introduction	163
C.2	Common Steps	164
C.3	Cost Assessment Using Publicly Available Information	169
C.4	Cost Assessment Using Supply Chain Data	175
C.5	Cost Assessment by Derivation	176
D.	Overhead Lines	177
D.1	Description of the Technology	177
D.2	Overhead Line Components	178
D.3	Overhead Line Construction	182
D.4	Overhead Line Maintenance and End of Life Considerations	189
D.5	Application of the Technology	190
D.6	Alternative Overhead Line Approaches and Anticipated Future Developments	191
E.	Underground and Submarine Cables	205
E.1	Technology Description	205
E.2	Power Cable Components	206
E.3	Cable Maintenance and End of Life	214
E.4	Cable Civil Works & Installation	216
E.5	Application of the Technology	225
E.6	Anticipated future developments	229
E.7	Submarine Applications	229
E.8	Submarine Power Cable Components	230
E.9	Submarine Cable Maintenance and End of Life	232
E.10	Submarine Cable Installation Works	233
E.11	Application of the Technology	237
E.12	Anticipated Future Developments	237

F. Tunnels	239
F.1 Introduction	239
F.2 Technology Description	239
F.3 Tunnel Design	245
F.4 Installation Works	246
F.5 Operation, Maintenance and end of life	251
F.6 Application of the Technology	252
F.7 Anticipated future developments	255
G. High Voltage Direct Current	257
G.1 Introduction	257
G.2 A.c. vs d.c. Transmission	257
G.3 Technology description – HVDC	261
G.4 Principal Cost Components	267
H. Alternative Technologies	269
H.1 Series Compensation	269
H.2 Superconductors	276
H.3 Gas-insulated Line and Pressurised Air Cables	282
I. Losses	289
I.1 Introduction	289
I.2 Calculating the Cost of Energy Losses	290
I.3 Assessment of Losses	292
J. Environmental	297
J.1 Introduction	297
J.2 Key Environmental Considerations associated with Electrical Transmission Technologies	297
J.3 Comparative Impacts Respective to Technology Selection	298
J.4 Environmental Cost Components	303
K. Carbon	306
K.1 Introduction	306
K.2 Emission Sources	306
K.3 Emission Reporting in the Transmission Sector	308
K.4 Assessment Methodology	310
K.5 Assumptions	312
K.6 Discussion	314
K.7 Conclusions	322
L. Bibliography	323

M.	Letter from Project Board	328
N.	List of Organisations Approached	330
O.	Abbreviations and Acronyms	333

Foreword by the IET

This report presents a review and comparison of technologies that could credibly be deployed in the next decade to extend and enhance the capacity of the electrical transmission network of Great Britain. The transmission network connects generators, high demand industrial sites, interconnectors, large scale storage and the distribution networks that carry power to most energy users and will require significant expansion under the UK's decarbonisation plans. A similar report was published by the Institution of Engineering and Technology (IET) in 2012. Since then, technology has moved on, most particularly in the area of high voltage direct current (HVDC). As well as providing updated cost estimates, this new report provides information on technology options that have become much more established since the earlier report or that are making progress towards commercial viability.

The IET has overseen the preparation of the report through a Project Board established specifically for the purpose and comprising senior figures with expertise in electrical power systems and environmental assessment. Details of Board membership are given below. A consultancy firm, Mott MacDonald, has been responsible for the collection of data and preparation of the report, the conclusions of which have been endorsed by the IET.

In the global energy system, "do nothing" is not an option. The world – and, to comply with its international obligations and legislated emissions reduction targets, the UK – needs to reduce its dependency on fossil fuels. We have the technology to do that, providing us with low carbon forms of energy that, in respect of renewables, are now cheaper than fossil fuels. Reduced global warming, less atmospheric pollution from particulates and nitrous gases, and reduced dependency on imports of fuels are clear wins. Access to and utilisation of low carbon energy depends on the electricity network. For resources developed at scale and requiring the energy to be transferred over, potentially, hundreds of kilometres, that means transmission networks typically operating at 275,000 volts (275 kV) or 400 kV and above (plus, in Scotland, the 132 kV network).

In late summer 2023, the Electricity Networks Commissioner appointed by the then UK Government published a report on how to accelerate the deployment of strategic electricity transmission infrastructure in Great Britain. He noted that, at present, "the expectation is that strategic transmission may take twelve to fourteen years from identification of the need to commissioning" and that "very few new transmission circuits have been built in the last 30 years and a dramatic increase will be required through to 2050". Among his 18 recommendations were that "a new document [of] Electricity Transmission Design Principles should be created", that consenting processes in England, Wales and Scotland should be reformed, and that "a clear and public set of guidelines for Community benefit should be established". In November 2023, the then Government published its responses to the Commissioner's recommendations, accepting many of them and setting out next steps for putting them into practice.

The review of transmission network technologies presented here provides information that is relevant to several of the Electricity Network Commissioner's recommendations. It also highlights that none of the technologies is without its downsides. For example, underground cables have lower visual impact than overhead lines, but they have adverse environmental impacts of their own and much higher cost; long high voltage cables also present serious electrical engineering difficulties. Development of transmission capacity using subsea cables off Britain's coast might reduce the need for either onshore overhead lines or underground cables but it, too, would have cost and environmental impacts. Moreover, it would not eliminate the need for onshore capacity which will still be needed to reach electricity users.

A second, very important lesson from the work carried out by the consultants for this report is that there are major supply chain bottlenecks, reported by the main manufacturers of all transmission equipment and construction contractors, in particular in the manufacture of cables. Almost all of the manufacturers reported full order books and difficulties in keeping up with delivery timescales on existing contracts.

The supply chain's full order books mean that the cost data available to this report's authors on established technologies are at risk of becoming out-of-date quite quickly due to inflationary pressures on supply chain capacity and volatility of prices for key commodities. On the other hand, for newer technologies where there is little or no deployment experience at the kind of scale required for a practical transmission system, there is inevitably a degree of speculation about what they would cost and how they would perform. With those caveats about changes to prices, one finding is that the relative costs of different technologies, in particular between overhead lines and underground cables for onshore network capacity, have changed little since the earlier review in 2012.

There is a rich body of information presented in this report about the different technologies available to enable increased transfer of electrical power across Great Britain via the high voltage transmission network, not just cost. However, in practice, not all of the options presented will be possible in each specific set of circumstances and, of those that are, a recommendation of which to use depends on those precise circumstances. The information here is intended to help the reader understand the options; it is not enough to decide which option should be adopted.

The cost estimates presented here of course depend on a number of assumptions that must be made. These are recorded in the report; sensitivities to variations in those assumptions are also provided. For example, build costs are an obvious point of difference between different technologies, both the variable costs that are proportional to the length of an overhead line, underground cable or subsea cable, and the fixed costs that are incurred for a development of any length. The latter are of particular significance in the case of an HVDC connection that requires a large converter station at each end to provide an interface between the direct current system and the main transmission system that uses alternating current (AC). The technologies also differ in terms of the energy losses that are experienced when transmitting power. Over the lifetime of the asset – typically 40 years or more – the cost of the extra energy that must be generated to compensate for these losses can be significant. In order to quantify that cost, assumptions must be made both for how much power the asset typically carries and what the cost of the extra generation is.

In the UK's contribution to mitigation of global climate change and the transformation of our energy system to one that has zero carbon emissions and not only safeguards but improves security of supply, perfection is impossible but pace is essential. The new Government elected in July 2024 has set a target of 'clean power' by 2030. This means that timescales for development of major onshore transmission infrastructure must be reduced. As the Electricity Networks Commissioner observed, more speed is needed at every stage of a transmission project, not least consenting. Any delays to facilitating decarbonisation of the electricity system will have major knock-on effects across all parts of the economy, not least those sectors that are hardest to abate making compliance with the 6th Carbon Budget and Net Zero target much more difficult to achieve.

To move us forward and get the transmission network capacity we need, what is required, firstly, is recognition that nothing is without its downsides. Then, we need a rational debate on the best available options, and trust in institutions, processes and expertise (which needs to be built up). Judgments will need to be made, informed by people's preferences on the balance between national emissions reduction imperatives, local environmental or social impacts, and

energy users' willingness to pay. The Project Board commends this report as a contribution to the understanding required for society to make those judgments.

Keith Bell on behalf of the Project Board

Project Board Membership:

Name	Organisation
██████████ FRSE, FHEA, CEng, BEng (Hons), PhD, MIET	University of Strathclyde
██████████, OBE, DSc, FEng, CEng, FIET	Past President IET
██████████ BSc, MEng, CEng, MIET	Independent consultant
██████████ FRGS, BA (Hons), PhD	University of East Anglia
██████████	Institution of Engineering & Technology
██████████	Institution of Engineering & Technology

Commissioning organisations

- National Grid Electricity Transmission (NGET), the TO for England and Wales.
- SP Transmission plc (SPT, a subsidiary of SP Energy Networks, or SPEN), covering south and central Scotland.
- Scottish Hydro Electric Transmission plc (SHE Transmission or SHET, part of Scottish and Southern Electricity Networks, or SSEN), covering the north of Scotland.

The commissioning organisations were excluded from the preparation of the report and consideration of its conclusions, except for a late review for factual accuracy.

MP Foreword

As the Chair of the All-Party Parliamentary Group on Infrastructure (APPGI) and the Government's Business Champion for Construction, I am pleased to welcome this independent report brought forward by the Institution of Engineering and Technology (IET). This comprehensive examination of the costs associated with electricity transmission network technologies represents a significant contribution to the ongoing public debate surrounding our energy infrastructure and the future of electricity transmission in the UK.

Demand for reliable and sustainable energy solutions is greater than ever. It is essential that we have a clear understanding of the economic implications of different transmission technologies. The report's findings provide valuable insights into the cost-effectiveness of these technologies, enabling the informed decisions that will shape the future of our energy landscape. As we strive to meet our climate targets and transition to a low-carbon energy system, it is crucial to understand the financial aspects of our infrastructure choices.

This report highlights the various technologies available for electricity transmission, and examines their respective costs, benefits, and potential impacts on consumers. By presenting a balanced analysis, the IET have created a resource that can guide policymakers, industry stakeholders, and the public in their future discussions on energy infrastructure.

I encourage all stakeholders to engage with the findings of this report and to consider the implications of these technologies on our energy security, economic growth, and environmental sustainability. It is imperative that we foster informed discussions that take into account the diverse perspectives of all parties involved. By doing so, we can work together to make decisions that will enhance our electricity transmission network, ultimately benefiting consumers and contributing to our national energy goals.

As we navigate the complexities of modern energy demands, it is essential to recognise the importance of collaboration between government, industry, and communities. This report serves as a foundation for that collaboration and providing a framework for dialogue that will highlight opportunities for innovative solutions and the implementation of new technologies.

I commend the IET in producing this report and for their commitment to advancing our understanding of electricity transmission technologies. I look forward to the discussions that will follow and the positive impact it will have on our energy infrastructure planning and policy-making.

Chair of the All-Party Parliamentary Group on Infrastructure

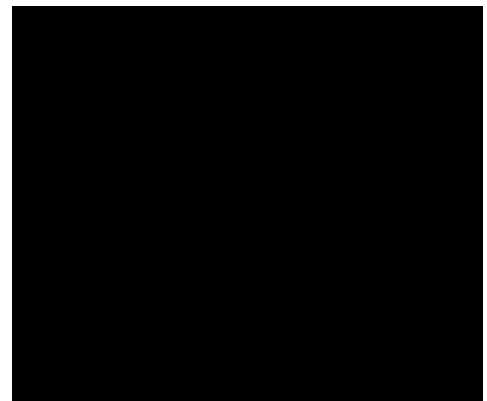

Use and Limitations of Report

This report has been produced on the basis of data provided to us by a variety of stakeholders between Q3 2022 and Q1 2023. The purpose of the report, as described in more detail in the introduction, is to provide an independent comparison of different technology types which may reasonably be expected to be deployed on the GB electricity transmission system within the next 10-15 years.

The comparison considers cost as well as a number of other factors. Whilst an indication of lifetime costs for each technology option is provided, this is for comparison purposes only and has been based on representative examples of situations, as opposed to specific projects. The extent to which the costs of one transmission technology are greater or lesser than those of another can vary considerably according to the specific circumstances of any particular project. As such, this report should not be used by any party for the purposes of estimating project costs.

Transmission technology is complex and this report can only act as a guide and cannot be used as a substitute for proper application of engineering and costing principles to transmission related projects. The report should not be used as a reference source in relation to the commercial, technical, economic, or financial performance of projects. Mott MacDonald therefore accepts no liability and makes no warranties or guarantees, whether actual or implied, related to the ultimate commercial, technical, economic or financial performance of projects which reference this report.

Executive summary

Decarbonising energy will require a major investment in new electricity transmission. Reports¹ estimate that by 2035 we need to build five times more onshore transmission infrastructure than we have built in the last 30 years, and four times the amount of offshore transmission infrastructure than currently exists. The December 2024 “Clean Power Action Plan²” accelerates this requirement.

This report updates earlier work³ to explore the relative lifetime costs, and other characteristics, of different electricity transmission technologies for deployment in Great Britain in the next 10-15 years. It seeks to provide an objective basis for comparisons to be made in public discourse.

Costs and benefits of different technologies depend heavily on the specifics of individual transmission projects, their locations, and their desired outcomes. This report provides indicative costs that need to be read in the context of these variables and is based on data collected in late 2022 and early 2023. Whilst costs may have changed since this data was gathered, for the purposes of comparison between technologies, the information remains valid.

Costs in the executive summary are presented as “lifetime power transfer costs” which include the costs of construction, operation and maintenance and an allowance for energy losses. In the executive summary the figures used are the average costs for each technology.

Onshore Transmission cost guidance

Based on typical UK circuit lengths and configurations⁴, the average lifetime cost for alternating current (a.c.) overhead lines, using conventional lattice towers, is around £1,190/MWkm. This is a quarter to a fifth that of buried a.c. underground cables at £5,330/MWkm. Putting those cables in newly built tunnels is around two and a half times more expensive still, at £14,100/MWkm. One MWkm is the ability to transfer one megawatt over one kilometre. As an example, and neglecting a lot of complex engineering caveats, using the average costs a 5,000 MW overhead line (consisting of two separate 2,500 MW circuits) of 15 km length could have a lifetime cost in the region of £90m, the equivalent buried cable £400m, and in a new tunnel £1,060m.

T Pylon overhead lines, whose appearance may be preferred by some observers in some settings, have a lifetime cost about 1.6 times that of conventional lattice tower lines, but are not suited to all applications. Other approaches such as reconductoring lines with high-temperature, low-sag materials, or installing synchronous compensation, series capacitors or quadrature boosters, can sometimes be applied to existing circuits to increase the network’s ability to transfer power. This can be cost-effective but generally results in modest, albeit useful, capacity increases. For example, reconductoring by replacing conductors but reusing existing towers, can be done quite quickly but may only increase the capacity of a line route by up to around 30% and, as a result of this limited capacity increase, has a lifetime cost of about £1,980/MWkm.

Offshore Transmission cost guidance

Offshore transmission has to be by use of submarine cable lying on the seabed. Alternating current is in common use but its electrical characteristics mean economic lengths are limited for

¹ <https://www.nationalgrid.com/document/149496/download>

² <https://assets.publishing.service.gov.uk/media/675bfaa4cfb84c3b2bcf986/clean-power-2030-action-plan.pdf>

³ <https://www.theiet.org/media/9376/electricity-transmission-costing-study.pdf>

⁴ Typical GB configurations are for double circuit installations i.e. two separate circuits sharing the same tower, or two cable circuits of the same rating, typically installed in adjacent trenches

high power transfers. Hence, high voltage direct current (HVDC) can be an economic choice for many applications offshore, in spite of the high cost of converter stations.

Offshore platforms are used where a substation is needed out at sea. These become much larger if HVDC, rather than alternating current, is used, driving up costs. Based on typical circuit lengths used in the UK, connections from land to an offshore platform (i.e. with one onshore substation and one offshore substation) could have an average lifetime cost of £11,200/MWkm for a.c., or £12,900/MWkm for HVDC.

Subsea HVDC can also be used to link different points of the onshore system (i.e. connecting two onshore substations) which could have an average lifetime cost of £6,170/MWkm for a 2000 MW system. When compared with the connection to an offshore platform, this clearly shows the cost premium associated with locating substations and converter stations offshore. Multi-terminal HVDC (with one offshore and two onshore converter stations) is a new technology, with lifetime costs around £12,500/MWkm.

It should be noted that HVDC costs expressed in £/MWkm are very sensitive to the length of the circuit involved because much of the investment is in the converter stations at each end, whose costs are independent of length. Choosing between alternating current and HVDC is a matter for project-specific optimisation.

System aspects, context and global supply chain pressures matter a great deal

The above costs are all for circuits of a particular transfer capacity. The power system, as a whole, needs to be resilient in moving power to where it is needed, which means that more capacity is often needed than the maximum power to be transferred. This may need additional circuits to be built. These decisions on system configuration are taken based on modelling studies that explore the impact, on the system as a whole, of individual circuits being out of service or failing, against agreed supply security criteria. The GB transmission system is critical national infrastructure upon which society and the economy relies. This brings an inevitable caution to the deployment of new technology, meaning, in practice, that some apparently attractive options may be considered technically too risky at a point in time.

The costs quoted above are based on multiple assumptions, and particular scenarios – for example for transfer capacity and length. Costs will vary considerably, not only with market conditions but also on terrain, access conditions, available space and many other factors. All technologies have their positive and negative attributes and some are simply not deployable in some contexts – for example, overhead transmission lines in dense urban landscapes, or underground cable in areas with challenging terrain or ground conditions.

Global market conditions have been inflationary for some time, and there is increased pressure on a limited supply chain as a result of the drive towards electrification and growth of renewables. This seems likely to persist, as this market driver is structural, and the development of more manufacturing capacity takes considerable time. This is particularly true when it comes to HVDC cables and converter stations, where limited manufacturing capacity globally, with high market demand, is resulting in long lead times. Data for this report came partly from the supply chain and transmission owners. Where not readily available from those parties, data has come from public domain sources or has been estimated.

Emerging technology options

New technology types for GB could include pressurised air cables (potentially 0.7-0.8 times the lifetime cost of a direct buried cable) and superconducting cables (potentially lower-cost buried alternatives to cables that would otherwise have to be in tunnels). These are emerging technologies which have not yet been fully proven, with further work needed before they could be used on the GB system. Our conclusions for these technologies should be treated as

indicative. Whilst they are likely to be effective in certain situations in the future, we would not expect them to displace overhead lines or underground cables in most instances.

For very long-distance onshore transmission, HVDC overhead lines or buried cables can sometimes be considered. For example, for a distance of 700 km, a 2000 MW HVDC circuit using underground cables could cost £2,270/MWkm, and an 8000 MW overhead line option £1,680/MWkm. HVDC converter stations^[2] are a significant fixed cost, which is the same regardless of circuit length, so over very long distances the cost on a per-km basis becomes much lower. Ultra-high voltage alternating current (765 kV) could also be considered, for which a single circuit could cost £880/MWkm. The HVDC and alternating current long-distance cases cannot be directly compared to the 400 kV cases as the configuration and functionality of the systems is different (for example, the 400 kV cases consider double circuit construction, whereas the long-distance cases generally consider single circuit construction). No long distance onshore HVDC underground cables (in excess of around 30 km) are currently operational in GB, and neither HVDC overhead lines nor 765 kV a.c. have been deployed in GB. In both cases, there would likely be significant planning and system integration challenges, meaning we consider short-term or medium-term deployment unlikely. These technologies will evolve and mature, and in the long-term may well find applications that can exploit their advantages in the future GB transmission system.

Non-cost aspects, their context dependency, and influence on technology selection

Technology selection is also influenced by a variety of non-cost characteristics, for example, environmental impacts, carbon intensity, local impacts, technological maturity, adaptability to different system conditions and future needs, resilience to extreme weather and associated repair times, and time to deliver. Many of these impacts are very different in the construction phase compared to when the assets are in long-term operation, but both matter. As with cost, each of these is contextual and project specific – for example, perceptions of visual impact will be higher in some landscape settings than in others.

It is evident that the assessment of non-cost characteristics is highly dependent on the context within which the project is deployed, and thus a generic assessment and comparison is not only inappropriate but potentially misleading. A qualitative description of non-cost characteristics of each technology has been included within this report.

Comparison with earlier IET work

This work is an update of a 2012 study undertaken by another firm⁵, which we have updated and expanded. Our report explores various scenarios which show a 4 - 5 times lifetime cost difference between overhead lines and equivalent buried cables (the earlier study indicated 5 – 6 times), and 1.8 - 3.7 times difference between buried cables and cables in tunnels (the earlier study found 1.4 - 2.7 times). Our work has also considered HVDC and offshore technologies in greater depth, given they are now so relevant. We have not costed for gas-insulated lines, as done in the 2012 work, as they are unlikely to be used outside a substation environment.

Conclusion

This work is intended to give a broad context for assessing relative costs of different technology choices for electricity transmission. Over time we would expect technologies and their costs relative to each other to evolve, something to take into account if reading this report at some point in the future. Our report should not be used to make choices for individual transmission projects, as this would need much more specific study.

^[2] These are required to convert alternating current to direct current, and vice versa.

⁵ <https://www.theiet.org/media/9376/electricity-transmission-costing-study.pdf>

1 Introduction

1.1 Introduction to the Report

Mott MacDonald was appointed to provide an updated document to replace the Electricity Transmission Cost Study (<https://www.theiet.org/media/9376/electricity-transmission-costing-study.pdf>), which was originally produced in 2012. The 2012 report was intended as an independent authoritative document, comparing the costs of underground cables (UGC), overhead lines (OHL) and subsea cables, and was expected to provide supplementary information to support the planning process in respect of decisions made by the transmission owners (TOs). At the time, several electricity transmission infrastructure schemes were passing through the planning approvals process and aspects of these schemes were a focus of discussion by Members of Parliament (MPs), members of the public, and campaign groups. Areas of sensitivity at the time included the costs that the TOs had put forward for underground and subsea cabling as potential alternatives to overhead line proposals.

Whilst much of the 2012 report remains relevant, it has been recognised that substantial extensions to the transmission network are planned as part of the ‘pathway to 2030’ and ‘beyond 2030’ initiatives⁶ to connect new offshore wind generation and that it would, therefore, be appropriate to review and update the work. The update is intended to reflect technology developments, cost evolutions, further implementation experience, and potential new operational demands, as well as presenting new comparative data on areas such as carbon footprint and environmental impact.

It is recognised that the extent to which the costs of one transmission technology are greater or lesser than those of another can vary considerably according to the specific circumstances of any particular project. Nevertheless, an independent and authoritative report should provide a useful point of reference against which to consider options for enhancement of the transmission network’s capacity and help inform public debate and decision-making on proposals for these and other electricity network projects.

1.2 Purpose of Report

The primary objective of the 2012 report was to provide an authoritative view on the comparative costs of underground and subsea cabling versus overhead power lines. Whilst this remains one of the objectives of the current report, this update also considers other factors which must be taken into account when considering such options now, and also introduces a number of new technology areas. The primary purpose of the current report is an evidence-based, objective engineering assessment of credible options for GB implementation of additional or replacement electricity transmission capacity. This is based on available technologies which might be considered as viable for deployment within the Great Britain National Electricity Transmission System (NETS), with cost ranges and some wider implications including environmental considerations.

The report is not to be relied upon (for example, by being quoted as a reference source for project costing or investment decisions) by any party, and the data presented is not suitable for tasks such as pricing of projects or making investment decisions. It is intended to provide general guidance as to the comparative costs, merits and drawbacks of different technologies, and should be treated as indicative only.

⁶ <https://www.neso.energy/publications/beyond-2030>

The report has been overseen by a Project Board established by The Institution of Engineering and Technology (IET). The IET has provided direction and oversight in the production of the report with a view to confirming that the report fulfils its intended function and is fit to be published. The objective of this arrangement is to demonstrate that the conclusions of the report are objectively based, independent, and not influenced by the TOs. With that in mind, the IET has also provided its own independent foreword to this report.

The Terms of Reference (see Appendix A) agreed between Mott MacDonald and the IET Project Board define the scope of the assessment, the technologies to be considered, and the high-level approach.

1.3 Presentation and Structure of Report

By necessity, the main body of the report contains a level of technical detail, and we expect that most of the intended readers would have an appreciation and basic understanding of the areas being discussed. Technical appendices are then presented containing a greater level of technical detail in a number of areas. We have provided a separate executive summary intended to be accessible to a wider audience. Appendix O contains a list of abbreviations and acronyms.

The report has been broadly structured in the same manner as the 2012 document, for reasons of familiarity to most users, having a relatively succinct main document, supported by a suite of technical appendices that provide further detail in specific areas. Additional detail has been added in some areas to provide greater context. Table 1.1 presents an overview of the report structure.

Table 1.1: Structure of Report

Section	Title	Description
1	Introduction	A general introduction to the report.
2	Electricity Transmission in Great Britain	Overview of electricity transmission in GB, the types of technologies available to the TOs, how these may be deployed and network planning considerations.
3	Scope and Methodology	Description of the overall approach and methodology taken for the study, along with the scope and assumptions.
4	Cost Assessment	Cost assessment of the chosen technologies and cost-comparison.
5	Discussion of Cost and Non-Cost Characteristics	Summary of costs for each technology studied, and qualitative discussion of non-cost characteristics.
6	Main Findings	Summary of main conclusions which can be drawn from the preceding sections. The conclusions combine the findings of the cost assessment and description of non-cost characteristics.
Appendix A to O	Various	Variety of appendices including technical, environmental, carbon and other information. These provide more detailed descriptions of the areas described in the main report, including further technical information.

1.4 Acknowledgements

Our research for this report has drawn on a wide variety of information sources including manufacturers, suppliers, installation contractors and other organisations. A full list of organisations approached is provided in Appendix N. We have also used public domain information where possible to support our views. A bibliography is presented in Appendix L. Whilst the report has been produced independently of the TOs, they have also contributed data

which has been used in our analysis. Contributions have been received from the three GB TOs, namely:

- National Grid Electricity Transmission (NGET), the TO for England and Wales.
- SP Transmission plc (SPT, a subsidiary of SP Energy Networks, or SPEN), covering south and central Scotland.
- Scottish Hydro Electric Transmission plc (SHE Transmission or SHET, part of Scottish and Southern Electricity Networks, or SSEN), covering the north of Scotland.

The level of detail presented in this report is highly dependent on the information provided by the different parties, and as such we gratefully acknowledge their contributions and the time and effort involved.

2 Electricity Transmission in Great Britain

This study relates to electricity transmission assets within Great Britain (GB) and specifically those assets which determine the capacity of the network to move power from its source (generating units, interconnectors that are importing or energy stores that are discharging) to the consumer. For clarity, this report does not cover assets located in Northern Ireland. This section of our report introduces the reader to the current arrangements in place for electricity transmission in GB. We have also presented the technologies considered in this study, challenges faced with each technology type, and the trade-offs which are to be considered, along with an overview of factors which the TOs will need to take into account when undertaking network planning. This should provide the reader with a basic understanding of the types of technologies available to the TOs, an indication of where they may be deployed, and the reasons why.

2.1 Background to GB Electricity Transmission

In GB the electricity industry is regulated by Ofgem, an independent regulatory body charged with protecting the interests of current and future consumers. Ofgem issues licenses to different companies to operate the GB electricity and gas transmission and distribution systems. In respect of electricity, the main licensees are as listed in Table 2.1.

Table 2.1: Main Electricity Industry Licensees

Description	Role
Generators	<p>Responsible for generation of electricity, historically at large gas, nuclear or coal-fired power stations. Increasingly, there is a move towards generation from renewable sources, which is discussed further in Section 2.2 below, and the incorporation of storage facilities. Typically, large generators are connected to the transmission system, whereas smaller ones may be connected to the distribution system.</p> <p>Generally, a generator must hold an Electricity Generation License from Ofgem and must comply with the conditions of that License in order to participate in the electricity market.</p>
Transmission Owners (TOs)	<p>These companies own the transmission assets in Great Britain (such as overhead lines, underground cables, and substations), and are responsible for transmission of the electricity from sources of power to the main load centres at high voltage. Operation at high voltage is the most efficient means of bulk power transfer over long distances.</p> <p>Transmission Licenses are administered by Ofgem and primarily give exclusive rights to own/operate transmission assets within a defined geographical area. There are separate TOs for onshore in England & Wales (National Grid Electricity Transmission), South of Scotland (Scottish Power Transmission) and North of Scotland (Scottish Hydro Electric Transmission). Charges levied by the TOs are subject to periodic review by Ofgem, based on Ofgem's review of the TOs' projections of the level of investment required and their operating costs.</p> <p>In England and Wales, the transmission system generally operates at 275 kV and 400 kV. The transmission system in Scotland also includes assets at 132 kV.</p>
Offshore Transmission Owners (OFTOs)	<p>The OFTO regime was introduced by Ofgem in 2009 with the purpose of facilitating cost-effective and timely provision of offshore transmission connections, and to encourage efficient operation of those offshore and onshore transmission assets over their lifetime. To date, the assets have been designed and constructed by the windfarm developer and subsequently transferred to the OFTO upon completion, with the OFTO being responsible for their operation and maintenance.</p> <p>OFTOs are appointed by Ofgem and their income is largely fixed for the lifetime of the asset. They are obliged to hold and comply with the conditions of an OFTO license.</p>
Distribution Network Operators (DNOs)	<p>Distribution networks receive bulk power from transmission substations and deliver it at lower voltage levels (typically from 132 kV in England and Wales and 33 kV in Scotland down to low voltage) directly to homes and businesses. DNOs are generally responsible for the network up to the meter terminals in individual premises and their networks may have directly-connected generators embedded within them.</p>

Description	Role
	<p>DNOs require a Distribution License from Ofgem and their charges are controlled through periodic review.</p> <p>There are currently 14 DNOs in GB, although these are operated by only six different companies. Each DNO network supplies a defined geographic area. In addition, there are a number of independent DNOs (IDNOs) which are able to construct and own local distribution facilities without geographic limits.</p>
Electricity Supply Companies	<p>Electricity supply companies are responsible for purchasing electricity and selling it to consumers. They are also responsible for ownership and operation of customer meters. An Electricity Supply License is required from Ofgem.</p>
Electricity Interconnectors	<p>Electricity interconnectors provide a connection between the GB electricity transmission system and those of other countries. Currently there are eight interconnectors in operation with several others under development. An Interconnector License is required from Ofgem.</p>
National Energy System Operator (NESO)	<p>Previously, National Grid was transmission owner in England and Wales, as well as GB system operator (known as NG ESO). In April 2019, following a decision by Ofgem, the ESO part of the business was legally separated from the transmission-owner business, and more recently ownership has been transferred from National Grid to the public sector as the National Energy System Operator (NESO)⁷. Its responsibilities include operating the electricity transmission system in real time, matching supply and demand, and maintaining statutory voltage and frequency limits. It also undertakes system level planning, identifying, at a high level, the interventions which are required, with the TOs being responsible for developing these into detailed designs. As part of its planning responsibilities, NESO is responsible for managing applications for load or generation connections to the National Electricity Transmission System (NETS). NESO operates under an Electricity System Operator License from Ofgem.</p>

Under EU regulations, which were adopted in the United Kingdom (known as the unbundling requirements and implemented under “The Electricity and Gas (Internal Markets) Regulations 2011”⁸), any single company is limited to owning a single category of either generation, transmission/distribution, and supply businesses.

The NETS comprises both onshore and offshore transmission networks. The onshore transmission networks are owned by three separate companies:

- National Grid Electricity Transmission plc (NGET) in England and Wales.
- SP Transmission plc (SPT, a subsidiary of SP Energy Networks, or SPEN) in south and central Scotland.
- Scottish Hydro Electric Transmission plc (SHE Transmission or SHET, part of Scottish and Southern Electricity Networks, or SSEN) in the north of Scotland.

These form the three GB regional Transmission Owners (TOs). Offshore assets which connect generators are owned by OFTOs with a new OFTO typically established for each windfarm which is connected. Interconnectors do not form part of the NETS.

This report concentrates on transmission assets and so the technologies chosen for study are those which are expected to be deployed by these three organisations in the short to mid-term, along with those which may be considered to be deployed by the TOs or by others (such as OFTOs) under the ‘pathway to 2030’ initiative⁹. Distribution assets are not considered further in this report.

An overview of the UK and Ireland onshore transmission system ownership is given in Figure 2.1 below.

⁷ <https://www.ofgem.gov.uk/energy-policy-and-regulation/policy-and-regulatory-programmes/future-system-operation-fso>

⁸ <https://www.legislation.gov.uk/ukxi/2011/2704/contents/made>

⁹ <https://www.neso.energy/document/262681/download>

Figure 2.1: GB and Island of Ireland Transmission Owners, 2024

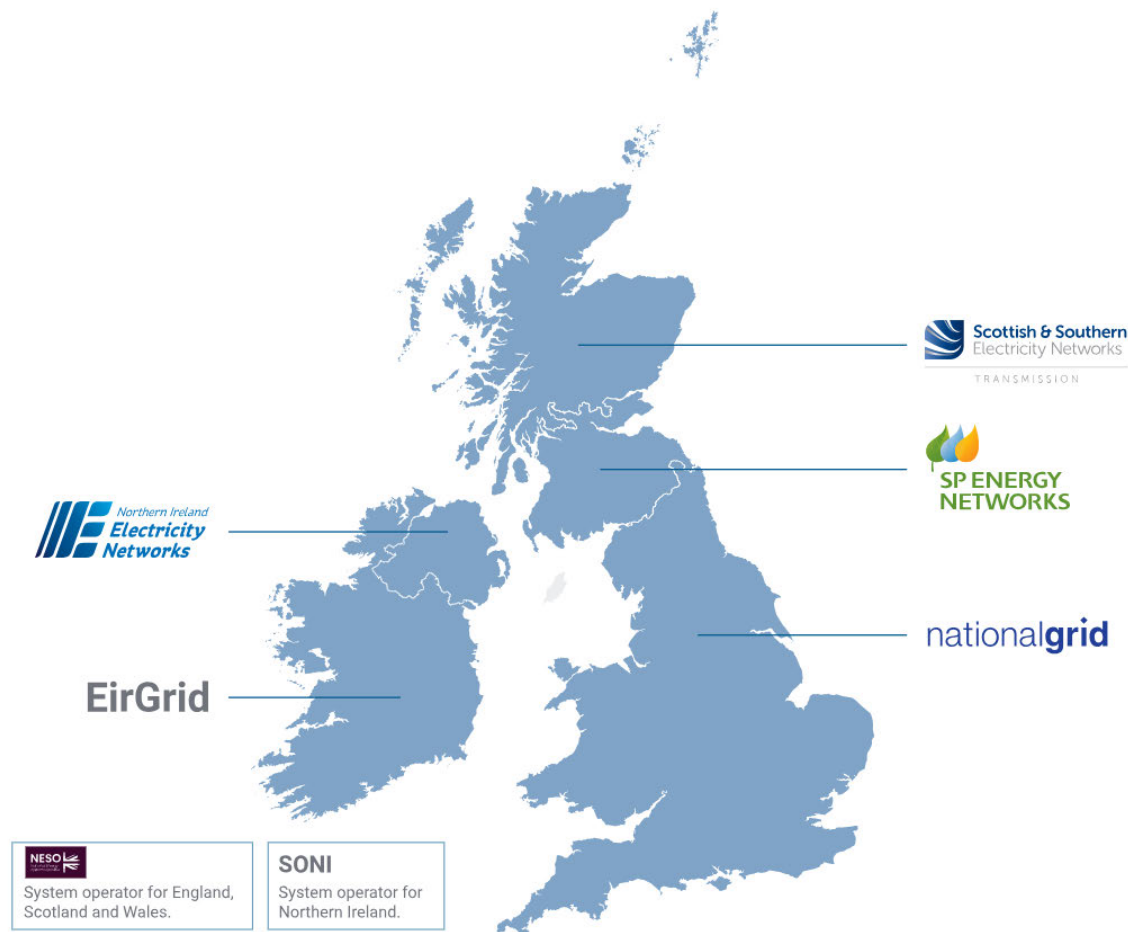

Source: "Who's my Network Operator?", Energy Networks Association, 2024. Available: <https://www.energynetworks.org/customers/find-my-network-operator>

When developing the NETS, as well as demonstrating the need for investment to Ofgem, in some instances it will be necessary to gain approval from the relevant planning authority (for example, if a new transmission line were to be constructed). Whilst it is not the aim of this report to describe the planning process in detail, we have highlighted some key points which need to be considered. It is noted that the process is different in England, Scotland and Wales, and there are also important differences between onshore and offshore projects. Some examples of the type of consent which may be required are as follows, noting that in some instances multiple permissions must be obtained, with further details available on National Grid's website¹⁰:

- Permitted Development – The TOs are registered as "statutory undertakers" which permits certain works to be undertaken without the need for planning permission. Subject to limitations, this generally applies to the installation of underground cables, and the extension of substations.
- Local Consents - Planning permission from the local planning authority. Usually this would apply to the construction of some new substations, some extensions of substations, and installation of some new onshore cables.
- National Consents - Construction of an overhead line requires consent from the Secretary of State (England & Wales) or the Scottish Minister. In England & Wales, new lines operating at a voltage ≥ 132 kV and with a length ≥ 2 km are designated as Nationally Significant

¹⁰ <https://www.nationalgrid.com/electricity-transmission/network-and-infrastructure/planning-and-development>

Infrastructure Projects (NSIP) and require a Development Consent Order, a process administered by the Planning Inspectorate (a function previously performed by the infrastructure planning commission (IPC)). In Scotland, consents are managed by the Scottish Government Energy Consents Unit. This is not generally required for the construction of substations or installation of cables, although in some circumstances this could still apply.

- Marine License – From the Marine Management Organisation (England), Natural Resources Wales (Wales), and Marine Scotland (Scotland). This would apply to activities in or over the sea, or under the seabed, within territorial waters (up to 200 nautical miles). This would typically apply to the installation of submarine cables in these areas, and installation of offshore substations.
- Permits and Licenses – In addition to the items above, certain permits and licenses may be required to undertake the works. These often depend on the nature of the work and are sometimes obtained by the contractor appointed to undertake the work, as opposed to by the TO.

The TOs will need to satisfy the authorities across a number of areas as required by relevant legislation (for example, the Town and Country Planning Act), such as with regards to the impact on the environment and local communities, resilience to climate change, and visual impact. Particularly in the case of an overhead line, it will be necessary to demonstrate that other solutions have been considered, and that the costs or technical limitations of the alternatives mean they are not suitable. The Holford Rules¹¹ provide further guidance in this regard.

2.2 Pathway to 2030 – key points of reference

2.2.1 Development of the GB electricity system

There is currently rapid growth in renewable generation sources, storage facilities, and in the number of interconnectors to nearby countries, as Great Britain seeks to decarbonise its economy. During the period over which this report was written there has been a change in UK government. The previous government had published a number of documents in respect of its energy strategy, targeting large-scale integration of offshore wind to the grid by 2030, decarbonisation of the electricity system by 2035, and achieving “net-zero” status in respect of national territorial greenhouse gas emissions by 2050.

The new government has an ambitious plan to achieve clean power by 2030¹², implying rapid growth in renewables, storage and flexible demand. It has commissioned NESO to produce a clean power plan, published in November 2024¹³. This plan shows scenarios by which this objective could be achieved. The government subsequently published its “Clean Power 2030 Action Plan”¹⁴ which sets out how it seeks to achieve its goals. The NESO clean power plan contents present two pathways to achieve clean power by 2030 which include very large amounts (between 43 GW and 50 GW) of offshore wind to be connected to the NETS by 2030. This compares to 14.7 GW connected as of September 2024¹⁵, representing a large increase with corresponding impact on how the network is designed and operated. It will need extension or reinforcement of the existing transmission system, including increasing the transfer capacity from sources of generation to load centres. As well as significant upgrades to, and expansion of,

¹¹ <https://www.nationalgrid.com/electricity-transmission/document/142336/download>

¹² <https://www.neso.energy/publications/clean-power-2030>

¹³ <https://www.neso.energy/document/346651/download>

¹⁴ <https://assets.publishing.service.gov.uk/media/675bfaa4cfbf84c3b2bcf986/clean-power-2030-action-plan.pdf>

¹⁵ <https://www.gov.uk/government/statistics/energy-trends-section-6-renewables>

Alternating Current (a.c.) infrastructure, this is also expected to lead to an increase in installation of High Voltage Direct Current (HVDC) infrastructure offshore (refer to appendices for further information on these technologies). Increases in grid connected battery storage (from 5 GW to over 22 GW), onshore wind (from 14 GW to 27 GW) and solar (from 15 GW to 47 GW) are also foreseen.

Beyond 2030 it is likely that much of the economy will electrify to decarbonise, including mobility, space heating and much of industry. This will likely require further significant development of the transmission system.

2.2.2 Development of the transmission system

It is clear that the TOs must invest heavily over the coming years to maintain and extend the NETS and facilitate the country's Net Zero ambitions.

In July 2022 NG ESO (now NESO) published a "Holistic Network Design"¹⁶ (HND) which considers both the onshore and offshore new infrastructure and reinforcement that is expected to be required to achieve the country's net-zero ambitions. Subsequently a "Beyond 2030" plan¹⁷ has been produced, which builds on the contents of the HND.

Whilst the HND was produced reflecting the ambitions of the government at the time, the new clean power plan (published in November 2024) appears to largely follow the HND. The HND provides a view as to the potential range of technologies which can reasonably be expected to be deployed on the GB NETS in the near- to mid-term. This document, along with Mott MacDonald's professional knowledge and experience, has informed our opinion as to which technologies should be considered as part of this study, as presented in Section 3 of this report.

2.2.3 Delivery of new transmission system infrastructure

Work has been undertaken by the UK's Electricity Networks Commissioner to explore how to accelerate electricity transmission network deployment¹⁸ (commonly referred to as the Winsor report). This was published in August 2023 and highlights recommendations for change across a number of areas such as the system operator, network planning, system design, the consenting process and the supply chain. The report has been welcomed by both the previous government and the current government, and many or all of its recommendations are likely to be taken forward. These will impact on how the overall process of planning and delivery is handled, but are not expected to materially impact the conclusions drawn in this report.

2.3 Network Planning Considerations and Challenges

This report focusses on providing an assessment of options for GB implementation of additional or replacement electricity transmission capacity. It is therefore useful to understand some of the network planning aspects and resulting challenges which NESO and the TOs need to address.

Network planning is a complex process with many different considerations. Here we present some key concepts at a high level, without going into significant technical detail. Identification of constraints and assessment of options is generally led by NESO with input from the TOs. The conclusion of this exercise is published by NESO in a document titled the "Network Option Assessment"¹⁹ (NOA). The TOs then undertake detailed design work to determine how best to deliver the solution identified in the NOA. Following the establishment of NESO, a number of

¹⁶ <https://www.neso.energy/document/262681/download>, July 2022

¹⁷ <https://www.neso.energy/publications/beyond-2030>

¹⁸ <https://www.gov.uk/government/publications/accelerating-electricity-transmission-network-deployment-electricity-network-commissioners-recommendations>

¹⁹ <https://www.neso.energy/publications/network-options-assessment-noa>

changes are expected, including the production of a strategic spatial energy plan, and centralised strategic network plan (CSNP), although it is expected to take some time for these to be fully implemented.

It is important to acknowledge that the development of the NETS must consider both technical and economic requirements. As the investments made by the TOs are funded via consumers' bills, Ofgem, the economic regulator, reviews planned investments to test whether they are "economic and efficient" and, therefore, in consumers' interests. Different levels of review may be undertaken, depending on the nature of the TO's planned investment. For example, some investments may form part of a larger programme of works which may have been included in a TO's regular business plan (refer to Ofgem's guidance on RIIO²⁰), whereas others, such as single large projects, may be reviewed individually (refer to Ofgem's guidance on Large Onshore Transmission Investments²¹). Ofgem's review is intended to ensure that consumers only pay for investments which are necessary and that bills are kept at a level that reflects this. TOs are, therefore, required to undertake significant optioneering exercises at an early stage of project development, to determine the most economic and efficient way to deliver a required output. Further, the requirements of the relevant planning authorities and associated legislation, as outlined in Section 2.1, must also be satisfied.

The GB transmission system is critical national infrastructure, essential to the wellbeing of society and the performance of the economy. It needs to be resilient, with minimal risks of failure. NESO maintains a document called the Security and Quality of Supply Standard (SQSS), which sets out how the NETS is to be planned and operated²². The SQSS defines, in detail, the technical criteria to be adopted to provide a high quality of supply to customers (for example, by maintaining voltage and frequency within a defined range), whilst also delivering a reliable supply by creating a network which is resilient to disturbances (for example, faults).

In order to meet the SQSS requirements, it is generally necessary to provide multiple paths to connect demand (customer loads) to sources of generation. This is because electricity transmission networks are sensitive to sudden large losses of either load or demand, which have the potential to de-stabilise the network and cause further disturbances. Steps are therefore taken, when designing and operating the NETS, to limit the maximum loss to specified levels by incorporating suitable levels of redundancy and incorporating appropriate response mechanisms.

Similarly, it must be possible to maintain and improve/extend the transmission system whilst still ensuring a reliable supply is maintained for customers. It is necessary to remove assets from service to carry out these works and, during these periods, power must be transmitted via an alternative route whilst maintaining a level of resilience should a fault occur on the alternative source of supply. Security of supply and network planning are complex topics and there are many variations on how these objectives can be achieved, depending on the exact network conditions. However, in general, it can be considered that the transmission system must be able to maintain supplies in the event that two separate circuits are unavailable (sometimes referred to as "n-2" conditions). A very simplified graphic example is presented in Figure 2.2.

²⁰ <https://www.ofgem.gov.uk/energy-policy-and-regulation/policy-and-regulatory-programmes/network-price-controls-2021-2028-riio-2>

²¹ <https://www.ofgem.gov.uk/publications/large-onshore-transmission-investments-loti-re-opener-guidance>

²² <https://www.neso.energy/industry-information/codes/security-and-quality-supply-standard-sqss>

Figure 2.2: Simplified graphic example of n-2 requirements and indicative percentage of the total load carried by each circuit under different outage conditions

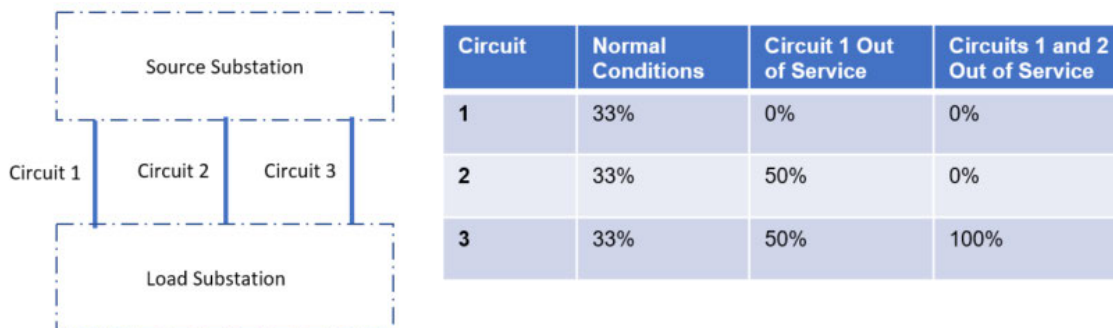

Source: Mott MacDonald

Referring to Figure 2.2, each of the different routes for transferring power is generally referred to as a circuit. This would typically consist of a number of different components such as circuit-breakers (network switches), transformers and conductors, which carry the electrical current. The conductors can utilise a number of technologies, as described further in Section 3, but historically two main methods have been used:

- Overhead line (OHL) circuits: In this instance a bare uninsulated conductor is supported at a safe distance above ground level using supports such as steel lattice structures (often referred to as ‘towers’ or ‘pylons’), or wooden poles (usually only used up to a voltage of 132k V). Insulation between the conductors, and to earth, is primarily provided by air, with the conductor attached to the support structure using insulators, as illustrated in Figure 2.3. Refer to Appendix D for further information on OHL.
- Underground cable (UGC) circuits: In this instance the conductor is separated from an outer conductive jacket (a sheath or screen layer) by an insulation layer. A variety of materials can be employed for this purpose but the most common are oil-impregnated paper and polyethylene. Such materials have superior insulation properties compared to air, meaning that the conductors’ ground clearance can be significantly reduced. This allows the conductors to be buried in the ground and the individual phases to be placed much closer together. A typical cross-section is shown in Figure 2.4. Refer to Appendix E for further information on UGC.

For reasons of efficiency, the GB high-voltage a.c. electricity system provides a three-phase supply and, therefore, most circuits actually require three separate conductors, each of which is insulated from the others and from ground (an explanation of the rationale behind this is not within the scope of this document). For economic reasons, it is also common to install multiple circuits together and this is most visibly apparent in overhead line systems, where a tower may support two separate circuits, one on each side of the tower, each with three conductor systems. An earth wire is also generally included on the top of the tower. Figure 2.3 provides an example of what such systems look like.

Figure 2.3: Example of double-circuit three-phase OHL

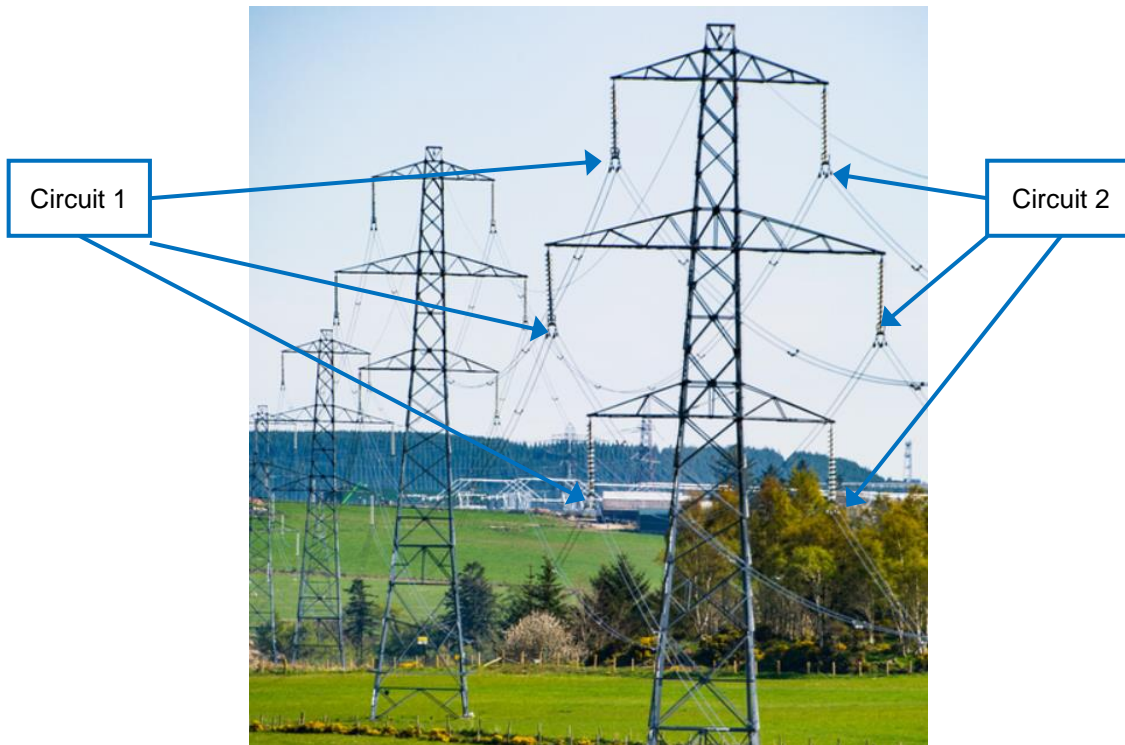

Source: "Project Map – Dunoon – Project Documents", SSEN, Jan. 2023. Available: <https://www.ssen-transmission.co.uk/projects/project-map/dunoon/>

Figure 2.4: a) Typical UGC, b) UGC Installed in Trough



Source: a) Reprinted with permission from CIGRE, Cable Systems Electrical Characteristics, Technical Brochure 531, © 2013. b) Reprinted with permission from CIGRE, Installation of underground HV cable system, Technical Brochure 889, © 2023.

All conductors have an inherent electrical resistance, which is dependent on the material and the cross-sectional area of the conductor. When current is passed through a resistance then heat is generated, which increases as the resistance and/or current increases. This heat must be dissipated to avoid the conductor reaching an excessive operating temperature. For a given conductor and set of environmental conditions, there is a maximum current which limits heat

generation to a level that can be dissipated without exceeding the specified temperature limit. This is referred to as the “thermal capacity” of the conductor system. If too much heat is generated in a cable system, then it may impact on the integrity of the insulation medium surrounding the conductors.

In an overhead line system, the heat causes the conductor to expand resulting in “sag”, which could lead to infringement of the necessary safety clearances to ground. It is normal practice in GB to define thermal capacity on a seasonal basis (i.e., considering the impact of lower ambient temperatures at certain times of year which means that in winter more power can be transmitted down most overhead lines than in summer).

One way to achieve a higher thermal rating would be to use a larger cross-section of conductor, which would reduce the resistance and thus the heat generated per unit length. However, there are constraints which limit the maximum size of cable conductor and, in practice, higher ratings often require the use of additional cables, impacting on cost and right of way requirements. For OHLs, increasing the conductor size increases its weight and wind/ice loads imposed on the towers. Therefore it also impacts on the size, visual appearance and cost of the towers to support the conductor.

Another way to increase thermal rating would be to use a different material. In particular, in cable systems, there is often a choice between using an aluminium conductor or a copper conductor. For a given cross-sectional area and unit length, the copper conductor has a lower resistance but the material cost is higher. For overhead lines, aluminium alloys offer the optimum combination of strength and electrical conductivity, therefore, alternative materials are rarely considered.

It is also possible to design for higher operating temperatures (allowing higher circuit ratings). With a.c. cables, modern insulating materials have a temperature limit beyond which they will start to deteriorate significantly, consequently, there is little scope for improvement. However, with OHL it is possible to design the line with additional ground clearance (allowing for more sag) or expensive “composite” type conductors can be employed, which reduce sag and thus allow higher conductor temperatures.

Finally, higher ratings can be achieved by enhancing the rate at which heat is dissipated from the conductor. With cables, this is influenced by the way in which they are installed (e.g., surrounding the cable with materials that provide better thermal conductivity than the native soil). With OHL, heat dissipation from the conductors increases with increasing wind speed, thus higher loadings can be sustained when weather conditions are favourable.

Calculation of the thermal rating of a circuit can be complex, although there are industry standards and guidelines that address the majority of applications. The rating is often expressed in amps (A) demonstrating the circuit’s current carrying capacity, or megavolt-amps (MVA), demonstrating the circuit’s apparent power transfer capability.

For planning purposes, the NETS is split into different regions separated by “boundaries”. These are typically established in locations where power flow limitations might be encountered, for example, as a result of thermal limits and SQSS considerations. As previously described, the purpose of the NETS is to facilitate bulk power transfer from one region to another and, in order to do so, it is often necessary to cross several boundaries. Consequently, reference is sometimes made to the ability of a project to increase boundary transfer capability (or capacity) and some of the technologies considered in this report are aimed at facilitating this by increasing the use of existing thermal capacity without construction of new circuits. The current system boundaries used in network investment planning can be found on NESO’s website²³.

²³ GB Transmission System Boundaries”, NESO, 2023. Available:
<https://www.neso.energy/document/274851/download>

NESO also publishes a document called the Electricity Ten Year Statement²⁴ (ETYS), which is updated annually, with the latest version at the time of writing being the 2023 document. This considers various possible future demand and generation scenarios over the coming ten-year period, and the associated impact on the network. The ETYS is expected to be replaced by the CSNP from 2026 onwards. Figure 2.5 is extracted from the November 2021 document²⁵ and demonstrates some of the challenges being faced.

Figure 2.5: 2021 Electricity Ten Year Statement extract



Source: "Electricity Ten Year Statement", NESO, Nov. 2021. Available: <https://www.neso.energy/document/223046/download>

The expectation in respect of the future transmission system is that there will be large quantities of wind generation connected in Scotland and the East of England, major load centres in the Midlands, London and the South East, and interconnectors to continental Europe available in the South East. With reference to Figure 2.5, this results in the following characteristics:

- During times of low wind, electricity may be imported via the interconnectors, and will need to be transported North.
- During times of moderate wind, there will be moderate power flows from Scotland and the East of England to service the load centres in the Midlands and London, and to allow some electricity export via interconnectors in the South East, with some import also occurring.
- During times of high wind, there will be significant power flows from Scotland and the East of England to service the load centres in the Midlands and London, and to allow electricity export via interconnectors in the South East.

The challenge faced by network planners is to come up with an economic and efficient solution to allow operation of a safe and reliable electricity transmission system, taking into consideration such dynamics. The solution outlined in Figure 2.6 is proposed in the HND, which is expected to cover the period to around 2030.

²⁴ <https://www.neso.energy/publications/electricity-ten-year-statement-etys/etys-documents-and-appendices>

²⁵ <https://www.nationalgrideso.com/document/223046/download>

Figure 2.6: Holistic Network Design proposal overview

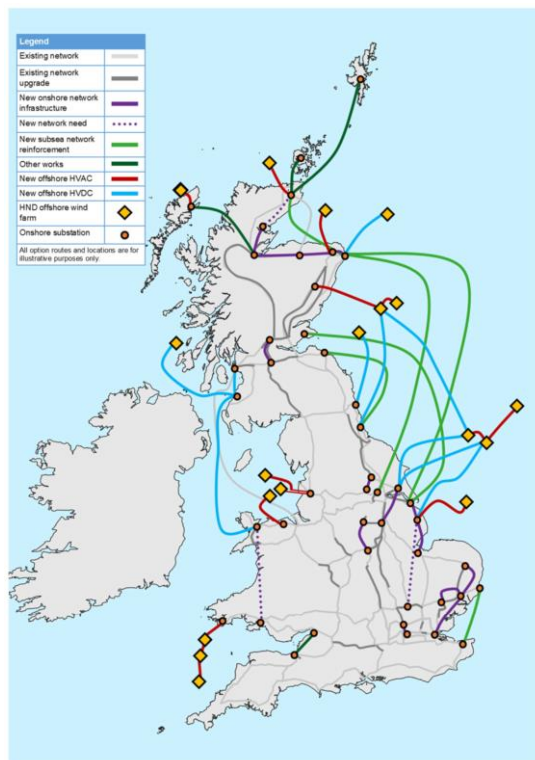

Source: "Pathway to 2030 - Holistic Network Design", NESO, Jul. 2022. Available: <https://www.neso.energy/document/262681/download>

Some aspects of this design are provided to facilitate the physical connection of the targeted 50 GW of offshore wind by 2030 to the onshore network. However, it also incorporates a number of offshore projects categorised as 'new subsea network reinforcement' which, although the associated circuits are located offshore, are intended to reinforce the onshore network. For example, there are several new circuits proposed from Scotland to different areas in England using circuits routed offshore. These circuits help to provide the necessary North-South transfer capability by avoiding (or relieving) some of the boundary transfer constraints in the onshore network. In addition to this, there are also a number of purely onshore projects which are required to be implemented.

2.4 GB Electricity Transmission Supply Chain

This section of our report is intended to provide a description of the supply chain in respect of electricity transmission in GB. Findings from our interaction with the supply chain, and some of the limitations that have been identified, are described further in Section 3 of this report.

Whilst the TOs each operate slightly different procurement strategies, the following describes some common options which are used for procuring services and materials in relation to transmission technology:

- Purchase of equipment from supplier and issue to contractor for installation
- Competitive tender of Engineering, Procurement and Construction (EPC) project to contractors, in which the contractor takes responsibility for the design, sourcing and installation of everything necessary

In general, it is the case that the TOs will not directly undertake work themselves in respect of capital investments. Instead, this is almost exclusively delivered by suppliers and/or contractors

engaged through competitive tendering. The TOs would typically undertake initial project development and would then hand over to the appointed contractor to undertake detailed design. Therefore, the overall capital expenditure (CAPEX) cost of a project can typically be allocated to the following high-level cost categories:

Table 2.2: Typical high-level cost components of a transmission project

Cost Category	Typical Scope	Source of Cost Data
Project Development	<ul style="list-style-type: none"> ● Optioneering ● Feasibility studies ● Planning permissions ● High-level designs ● Procurement/tendering 	TO or Project Developer
Detailed Design	<ul style="list-style-type: none"> ● Development of detailed design across all areas (civil, mechanical, electrical, marine etc.) 	Equipment Supplier, EPC Contractor
Cost of Materials	<ul style="list-style-type: none"> ● Substation Equipment ● Cable ● Overhead line materials 	Equipment Supplier, EPC Contractor, TO
Cost of Services	<ul style="list-style-type: none"> ● Civil works ● Installation ● Commissioning 	Contractor or EPC Contractor
Project Management and Overheads	<ul style="list-style-type: none"> ● Project Management Organisation ● Staff costs ● Legal fees, land use etc. ● Environmental costs ● Insurance and other overheads 	TO or Project Developer and Contractor or EPC Contractor
Risk/Contingency	<ul style="list-style-type: none"> ● Typically, the commercial risk allocation will be agreed as part of contract negotiations. A portion will then be built into the price provided by the supply chain, with a further allocation by the project developer or TO to cover residual risk 	TO or Project Developer, Equipment Supplier, and Contractor or EPC Contractor

For the main components of the power system, the market relies on a limited number of suppliers used by all TOs. These are, currently, largely European with a small number of others based in Asia. The products offered are required to be compatible with the requirements of the NETS and must be rigorously tested to demonstrate compliance with applicable technical standards before they can be placed in service. Similarly, there is a limited pool of contractors that have the ability and experience to undertake application design and installation.

It is worth mentioning that the 2012 study only included National Grid, which at the time was operating under an “alliance” model with an open-book commercial framework. The alliances comprised of an original equipment manufacturer (OEM), a contractor (civil works/installation/commissioning) and a consultant (detailed design, project management, etc.). Under this model, resources from the three alliance organisations, as well as National Grid, were managed as an integrated team, with the capacity to supply pricing information. This system is no longer in place and the TOs have primarily been delivering projects under separate framework agreements with contractors, suppliers and other parties bidding competitively. Consequently, there is a greater reluctance to share costing data that could be commercially sensitive.

Going forward, in order to deliver the work required to meet GB’s Net Zero ambitions, NGET has launched the “Great Grid Upgrade Partnership” (GGUP), which aims to deliver “£4.5 billion

worth of network infrastructure construction by 2030²⁶. This will use an “enterprise” delivery model, where supply chain partners work together in a collaborative manner to deliver results. In 2024, NGET has appointed two design and consenting partners, and five construction partners under this model. A similar enterprise model is also being used by NGET for the London Power Tunnels 2 project. It is expected that the GGUP will be used to deliver the upgrade works indicated in the HND, with other works (for example, condition-based asset replacement) being delivered under framework agreements and competitive tendering.

Whilst, in the past, the procurement of supply/installation services for high voltage transmission equipment in GB has been dominated by the three TOs, this is no longer exclusively the case. The government’s ambitions, in respect of electrification and growth of renewables, means that there are now renewable developers and interconnector developers in GB accessing the same supply chain as the TOs. This is particularly the case in respect of both onshore and offshore cables, and primary equipment (both HVAC and HVDC). A similar situation exists throughout Europe, with European TOs and developers accessing the same restricted market of suppliers/contractors, and therefore the demand on the supply chain is very high.

Much of the equipment is manufactured in specialised facilities and, in the case of cable factories, the specific manufacturing lines must be pre-qualified in accordance with specified technical requirements and procedures, a process which can take several years to achieve. Therefore, expanding manufacturing capacity is not straightforward and generally requires considerable investment in specialist equipment. Such investments must generally be supported by a robust order-book, thus, we would expect that capacity will tend to lag changes in demand. Consequently, in the current climate of rapid market growth, we are seeing significant lead-times being quoted for material supply and established suppliers less able to “accelerate” orders.

There have been some new supplier entrants into the GB market and we have seen evidence of TOs engaging with potential additional suppliers. Whereas these entrants may be able to supply the required materials within a shorter timeframe, there can be a trade-off as they are less familiar with GB requirements/working procedures and may not be able to offer the same level of technical support as established suppliers. As a result, the TOs and/or installation contractors may need to expend additional time and resources during the detailed design and construction/commissioning phase to accommodate this lack of local experience. In our experience it can take some time before supplying the GB market becomes embedded as “business as usual” within a new supplier’s organisation.

Whilst there have been several examples of new suppliers successfully becoming established in the UK market, the process can present challenges and involve significant cost and commitment of resources. Given the high level of worldwide demand, we do not anticipate that new suppliers will capture a significant market share and expect that the established supply chain will continue to supply much of the GB demand for high-voltage equipment.

It is also worth noting that at the time of writing this report there is considerable price volatility, particularly in Europe but also globally. Raw material prices have increased substantially and supply chain constraints have limited competitive pressure in the sector. Energy costs are also high, partly driven by Russia’s invasion of Ukraine in 2022 which led many countries to reduce their reliance on Russian gas. In turn these aspects have contributed to higher inflation and increased cost of living in many countries, with a corresponding increase in labour costs, along with variable exchange rates. As a result, there is currently significant price uncertainty within the supply chain, which is further discussed in Sections 3 and 4 of this report.

²⁶ <https://www.nationalgrid.com/national-grid-seeking-supply-chain-partners-great-grid-upgrade-partnership>

3 Scope and Methodology

3.1 Scope of Report

The TOs operate a large number of different types of assets, with operating voltages primarily ranging from 132 kV to 400 kV a.c. It would not be possible within the bounds of this report to produce a typical costing for each of those and, therefore, a limited range of technologies and operating voltages have been chosen for study. As the purpose of the study is to consider options which have the potential to be used to create additional or replacement bulk electricity transmission capacity, we have focussed on high-voltage, high-capacity solutions. Selection has been based on the following considerations:

- Technologies studied in the 2012 report have been included.
- The HND has been reviewed to form a view as to the additional technologies that NG ESO expects to be deployed within the next 10-15 years.
- Our knowledge, experience and professional judgement has been utilised to identify the types of technologies that might be deployed in the next 10-15 years.
- Discussions with the Project Board and TO Stakeholders in respect of the proposed areas for study.

As a result, we have selected a number of technologies and rating cases for study, as defined in Section 3.2, with justification for selection provided in the ToR. With some exceptions, these are generally restricted to 400 kV for a.c. systems, as this is the voltage at which we expect the majority of enhanced boundary capacity to be created, with some specific exclusions listed in the ToR.

Each of the technologies has been subjected to a whole-life cost assessment, which is detailed in Section 4 of this report. A qualitative review of non-cost characteristics has then been added, which is presented alongside the outcome of the cost assessment in Section 5. A suite of technical appendices provide further detail regarding each of the technologies and these are designed to substantiate the analysis found in the main body of the report. It is recognised that TOs operate assets at voltage levels lower than 400 kV and that, for some applications, new infrastructure of a lower voltage level is more appropriate. In order to address this, a sensitivity analysis is provided in Section 4 of this report, which covers some assets which are likely to be deployed at lower voltage levels.

3.2 Technologies and Ratings

We have divided the technologies which have been studied into three different categories, as detailed in Table 3.1, Table 3.2, Table 3.3 and Table 3.4. These tables provide further explanation as to the different technologies that have been chosen.

In general, it is valid to compare the technologies classified as “onshore” against each other, and those classified as “offshore” against each other. However, it would not be valid to compare an offshore technology directly against an onshore technology without further project context, as they serve a different purpose, have different ratings, and are used by the system operator in a different way.

Whilst some items classified as alternative technologies can be compared against the onshore technologies, others can only be considered on a standalone basis or compared against other alternative technologies. However, overall, it can be considered that the evaluations we have undertaken provide an indication of broad trends for the particular technology.

In order to be able to compare the technologies against each other, a “high”, “medium” and “low” rating has been defined and a reference configuration has been chosen for each technology which will allow it to deliver at least the specified rating. These defined ratings have been coordinated to allow like-for-like comparison and considering that many network reinforcements will use a mix of technologies. In practice, and particularly in the case of overhead lines, the technology may be able to deliver a capacity somewhat higher than the ratings we have specified. A more detailed description as to how the chosen ratings have been derived is included in the ToR in Appendix A.

A reference has also been provided for each technology to the relevant technical appendix where further information regarding the technology can be found. The following definitions and abbreviations are used in the tables (refer to the relevant technical appendix for further information):

- Overhead Line (OHL) – This refers to a system where electrical conductors are located above ground, generally on towers (or pylons) or wood poles supported by insulators, and which use air as an insulation medium.
- Underground Cable (UGC) – This refers to a system where electrical conductors are normally located below ground with a physical insulation medium, such as oil-impregnated paper or polyethylene.
- AAAC – All-aluminium alloy conductor.
- XLPE – Cross-linked polyethylene (an insulation material).
- HTLS – High-temperature low-sag.
- VSC – Voltage-sourced converter.
- LCC – Line-commutated converter.
- UHV – Ultra high voltage.
- HVDC – High-voltage direct current.
- HVAC – High-voltage alternating current.

Table 3.1: Technology categories

Category	Description
Comparable Onshore Technologies	<ul style="list-style-type: none"> ● Transmission networks have historically been formed of a ‘gridiron’ of alternating current (a.c.) transmission lines. Conventionally, a requirement for an increase in capacity is satisfied by constructing new links in the ‘grid’ and such interventions form a significant part of the HND proposals. ● The technologies considered are those suitable for constructing new passive point-to-point a.c. links in the grid, which do not provide dynamic control functionality. ● These technologies would include, for example, overhead line and underground cable circuits with similar ratings, which can provide similar functionality and be compared on a like-for-like basis in different situations.
Comparable Offshore Technologies	<ul style="list-style-type: none"> ● The HND is driven by an expected significant growth in offshore wind generation and, therefore, includes a large quantity of offshore assets to allow for connection of this generation capacity to the onshore network. Such assets would typically comprise of either a.c. or d.c. submarine cables, along with offshore substations. ● In addition, offshore assets are also to be installed in order to provide embedded HVDC links, primarily to provide high-capacity long-distance connections between different parts of the NETS, thus bypassing constrained areas of the onshore transmission network.
Alternative Technologies	<ul style="list-style-type: none"> ● With use of power electronics and other technologies, the natural power flows through the grid can be modified to make better use of the capacity of the existing passive a.c. transmission lines. This can allow an increase in network capacity without providing new links. The technologies considered are typically those that provide a level of dynamic control of power flows, such as quadrature boosters or

Category	Description
	<p>static series synchronous compensators. These technologies do not inherently provide new network capacity but ‘unlock’ spare capacity in existing circuits that could not previously be exploited due to constraints in the network topology. The effects of these technologies on network capacity are, therefore, not directly related to the investment made and need to be specifically assessed for each project.</p> <ul style="list-style-type: none"> • There are also certain technologies which could be employed by TOs in specific circumstances, for example, reconductoring of overhead lines to increase the rating of a circuit, use of superconductors, or use of multi-terminal HVDC systems. • For these technologies we have provided a typical example cost, along with a description of the circumstances where it may be deployed, and a description of the benefits which it may provide. • In general, it is difficult to compare these technologies on a like-for-like basis either with each other or with conventional reinforcement technologies. In some cases, a comparison against a specific case may be possible.

Table 3.2: Onshore technologies

Description	High Rating (3741 MVA)	Medium Rating (2494 MVA)	Low Rating (1247 MVA)	Mott MacDonald Comments
Onshore: OHL and UGC to be evaluated for 3 km, 15 km and 75 km route lengths. Tunnel to only be evaluated for 3 km and 15 km route lengths				
<p>400kV Overhead Line (Appendix D): Commonly used method of achieving bulk power transfer onshore in GB. Relatively high capacity at relatively low cost.</p>	<ul style="list-style-type: none"> • Double circuit on L13 Towers. • 3x700 mm² AAAC per phase. 	<ul style="list-style-type: none"> • Double circuit on L12 Towers. • 2x850 mm² AAAC per phase. 	<ul style="list-style-type: none"> • Double circuit on L8 Towers. • 2x570 mm² AAAC per phase. 	
<p>400kV Underground Cable – Direct Buried (Appendix E): Alternative to overhead line circuits for some applications. Generally lower capacity and higher cost, as compared to overhead line.</p>	<ul style="list-style-type: none"> • Two circuits, four trenches. • 3x2500 mm² copper conductor per phase. 	<ul style="list-style-type: none"> • Two circuits, four trenches. • 2x2500 mm² copper conductor per phase. 	<ul style="list-style-type: none"> • Two circuits, two trenches (i.e., one circuit per trench). • 1x2500 mm² copper conductor per phase. 	<ul style="list-style-type: none"> • Sensitivity Analysis to be provided in relation to ducted cable installation.
<p>400kV Underground Cable – in Tunnel (Appendix F): Application in GB mainly limited to city environments where insufficient space exists for installation of new circuits using traditional methods.</p>	<ul style="list-style-type: none"> • Two circuits, 4m diameter tunnel. • 2x2500 mm² copper conductor per phase. • Ventilation of 10m/s air speed. 	<ul style="list-style-type: none"> • Two circuits, 4m diameter tunnel. • 2x2500 mm² copper conductor per phase. • Ventilation of 3.5m/s air speed. 	<ul style="list-style-type: none"> • Two circuits, 3m diameter tunnel. • 1x2,500 mm² copper conductor per phase. • Ventilation of 3.5m/s air speed. 	

Table 3.3: Offshore technologies

Description	High Rating	Medium Rating	Low Rating	Mott MacDonald Comments
Offshore: HVDC and HVAC to be evaluated for 90 km, 180 km and 275 km route lengths. Evaluation for “embedded” configurations, and for onshore-offshore radial links				
HVDC Voltage Sourced Converter (Appendix G): Relatively recent technology which has made significant advances in recent years and is now well established	<ul style="list-style-type: none"> ● Single 2,000 MW bi-pole. ● 525kV, bundled pair, XLPE 2500mm² copper cable. 	<ul style="list-style-type: none"> ● 1,000 MW symmetrical monopole. ● 320kV bundled pair, XLPE 1800mm² copper cable. 	<ul style="list-style-type: none"> ● 500 MW symmetrical monopole. ● 320kV bundled pair, XLPE 1000mm² aluminium cable. 	<ul style="list-style-type: none"> ● Uplift to be provided for locating one of the converter stations offshore. ●
HVAC Submarine Cable (Appendix E): Well-established technology which is suitable for transmission of low to medium power levels over short to medium distances.	<ul style="list-style-type: none"> ● 4x500 MW circuits. ● 275 kV three-phase cable, 1200 mm² copper cable. 	<ul style="list-style-type: none"> ● 2x500 MW circuits. ● 275 kV three-phase cable, 1200 mm² copper cable. 	<ul style="list-style-type: none"> ● 1x500 MW circuit. ● 275 kV three-phase cable, 1200 mm² copper cable. 	<ul style="list-style-type: none"> ● Offshore Collector platform required for a.c. solution. ● Mid-point reactive compensation platform required for 180 km and 275 km a.c. route lengths

Table 3.4: Alternative technologies

Description	Configuration	Mott MacDonald Comments
Alternative Technologies: Typically standalone application for specific circumstances		
<p>400 kV Gas-insulated Line – direct buried (Appendix H): Used within a substation environment, where physical space limitations exist, or to connect two adjacent substations, such as a converter station and a grid substation. Generally carried above ground on steel support structures but can be installed in tunnels or culverts. No known application in GB in direct-buried configuration.</p>	<ul style="list-style-type: none"> ● Typical double circuit installation, direct buried. ● 3 km route length. 	<ul style="list-style-type: none"> ● Evaluation has included realistic rating which could be expected.
<p>400 kV Gas-insulated Line – in tunnel (Appendix H): As per direct buried solution but instead located within a tunnel. No known application in GB to date</p>	<ul style="list-style-type: none"> ● Typical double circuit installation, direct buried. ● 3 km route length. 	<ul style="list-style-type: none"> ● Evaluation has included realistic rating which could be expected.
<p>400 kV Pressurised Air Cable – direct buried (Appendix H): Emerging technology. Similar to gas-insulated line but using compressed air and with more flexible joints</p>	<ul style="list-style-type: none"> ● Typical double circuit installation, direct buried. ● 3 km route length. 	<ul style="list-style-type: none"> ● Differentiated from GIL due to use of SF₆-free technology. ● Evaluation has included realistic rating which could be expected.
<p>Superconducting Cable – direct buried (Appendix H): Emerging technology which has seen significant development in recent years. Some commercial applications now in service, although all outside GB. Could typically offer a solution for high-power transfer capability at lower voltage levels and seen as being suitable for densely populated urban environments where physical space constraints exist, potentially providing an alternative to the use of tunnels</p>	<ul style="list-style-type: none"> ● Typical double circuit installation, direct buried. ● 3 km route length. 	<ul style="list-style-type: none"> ● Evaluation has included realistic rating which could be expected. ● Restricted to short route lengths only which is expected to be the typical application of such technologies in the timeframe of this study.
<p>Multi-terminal HVDC Link (Appendix G): As per VSC HVDC system, but connecting multiple locations, as opposed to being point-to-point. Seen as a potential way of combining network reinforcement or interconnectors with the connection of offshore generation.</p>	<ul style="list-style-type: none"> ● Three-terminal link. ● 2,000 MW bi-pole. ● 525 kV bundled pair. XLPE 2500 mm² copper cable. 	<ul style="list-style-type: none"> ● Sensitivity analysis provided for locating one converter station offshore.
<p>Reconductoring of Existing Overhead Line (Appendix D): Using this approach, an existing overhead line can have its conductor replaced with one of a higher capacity. Increases in capacity of around 40-100% can be expected.</p>	<ul style="list-style-type: none"> ● Typical application of reconductoring with HTLS conductor. ● Consider 75 km route length. 	<ul style="list-style-type: none"> ● Evaluation has included typical capacity increase which can reasonably be expected.
<p>Alternative Tower Technologies for Visual Amenity Reasons or to Reduce Land Take (Appendix D): Historically, steel-lattice towers have been used but other types are available. Most recently, National Grid has employed the T-pylon design which is a monopile type structure. However, these have a higher up-front cost and are not suitable for all terrains.</p>	<ul style="list-style-type: none"> ● Application of T-pylons instead of conventional pylons. 	<ul style="list-style-type: none"> ● Sensitivity adjustment provided which could be applied to conventional overhead line designs.

<p>Increasing Use of Existing Thermal Capacity – Quadrature Booster (Appendix H): Can be used to increase boundary capacity by injecting a voltage to dynamically control power flows. Involves the installation of a large device essentially comprising of two transformers</p>	<ul style="list-style-type: none"> ● 2750 MVA Quadrature booster in line with NGET PST31. 	<ul style="list-style-type: none"> ● Substation extension requirements included.
<p>Increasing Use of Existing Thermal Capacity – Thyristor Controlled Series Capacitor (Appendix H): Can be used to increase boundary capacity by altering the impedance of a circuit. Involves the installation of a quantity of capacitors, reactor, thyristors, control system and associated connections. Allows for dynamic power flow control.</p>	<ul style="list-style-type: none"> ● “Typical” example of application of such technology. 	<ul style="list-style-type: none"> ● Substation extension requirements included.
<p>Increasing Use of Existing Thermal Capacity – Static Series Synchronous Compensator (Appendix H): Can be used to increase boundary capacity through altering the apparent impedance of a circuit by voltage injection. Involves the installation of power electronics devices, control system and associated connections. Allows for dynamic power flow control.</p>	<ul style="list-style-type: none"> ● “Typical” example of application of such technology. 	<ul style="list-style-type: none"> ● Substation extension requirements included.
<p>Onshore HVDC – 2 GW VSC (Appendix G): May be suitable for transmission of moderate levels of power over very long distances, using underground cable with minimal visual impact. Currently being deployed in a limited number of locations in continental Europe.</p>	<ul style="list-style-type: none"> ● Conventional bi-pole configuration. ● 525 kV XLPE cable. ● 700 km route length. 	<ul style="list-style-type: none"> ● Includes single circuit 400kV cable connection to an existing nearby substation.
<p>Onshore HVDC – 8 GW LCC (Appendix G): Generally established voltage for this capacity is ± 800kV, which has primarily been used in China but also in India, Russia and Brazil. Would be suited to point-to-point transmission of very large quantities of power over long distances</p>	<ul style="list-style-type: none"> ● Conventional bi-pole configuration. ● Overhead line conductors including metallic return. ● 700 km route length. 	<ul style="list-style-type: none"> ● Assumes existing lines are diverted into the converter station, or new outgoing lines are constructed (not included in assessment). ● In the event of a conductor fault, 4 GW capacity can be achieved using the metallic return.
<p>UHV Onshore a.c. Transmission (Appendix D): Generally established voltage is 765 kV a.c., which has been deployed in China, South Africa, Russia etc. Would be suited for transmitting very large quantities of power over long distances.</p>	<ul style="list-style-type: none"> ● Application of 765 kV overhead line. ● 700 km single circuit route. 	<ul style="list-style-type: none"> ● N/A.

Each of these technologies is discussed in more detail in the appropriate technical appendix to this main report. They are then also considered in the cost assessment with a qualitative analysis of non-cost characteristics added in Section 5.

3.3 Overall Approach

Table 3.5 provides a description of the general steps we took to develop this report.

Table 3.5: Steps in methodology

Title	Description
Definition Cases and Technologies to be studied	<ul style="list-style-type: none"> ● Following project commencement, we undertook a review of the cases and technologies which were studied in 2012. ● Some high-level studies were run in respect of cable rating calculations and an adjustment was made to the rating cases. ● A review of the technology areas resulted in addition of further technologies, as compared to the 2012 report, and removal of a small number of cases. ● The ratings and technologies were discussed and agreed with the Project Board and defined in the ToR. This provided the basis for the report going forward.
Data Capture	<ul style="list-style-type: none"> ● Following contract award, the list of suppliers contacted in 2012 was reviewed. This was updated, taking into consideration the current electricity transmission supply chain as discussed in Section 2 of this report. For example, the current framework contractors were all added to the list of parties to be contacted. A full list of organisations which were contacted is presented in Appendix N. ● An advance email, with a letter signed by the chair of the IET Project Board, was issued to all parties on the list, providing notice that we would be seeking input to the report. A copy of the letter is included in Appendix M. ● Following definition of the ToR, a number of “Requests for Information” (RFI) were produced. Separate RFIs were produced for primary equipment (including HVDC and offshore), overhead lines and cables. In the case of overhead lines, this was divided into multiple smaller RFIs, and for cables it was divided into offshore systems and onshore systems. ● The RFIs were issued to the supply chain as well as the TOs. Further information about engagement with these parties, and the data capture process, is given in Section 3.4. ● Information was also gathered from the public domain, with a list of reference sources provided in Appendix L. Details as to how the public domain information has been used are provided in Section 4 of this report.
Technical Analysis	<ul style="list-style-type: none"> ● Once the technologies to be studied had been defined in the TOR, a review of the 2012 technical appendices was undertaken. ● Much of the information presented in the 2012 report is still relevant and has not needed to be repeated in this report. ● In some instances, the previously-produced technical appendices have been refreshed to reflect developments since 2012, as well as the additional areas of analysis to be carried out in this report. ● In some instances, additional technical appendices have been provided to cover the expanded scope of this report. ● The technical analysis is presented in Appendix D to Appendix K.
Cost Assessment	<ul style="list-style-type: none"> ● Following completion of the data capture exercise, a cost assessment was carried out. This is described in more detail in Section 4 of this report and in Appendix C.
Assessment of non-cost characteristics	<ul style="list-style-type: none"> ● A qualitative assessment of non-cost characteristics was carried out, which has been combined with the outcome of the cost assessment and detailed within Section 5.
Main Findings	<ul style="list-style-type: none"> ● Whilst the analysis has been undertaken by Mott MacDonald, the IET has peer reviewed both the approach and findings at regular intervals. ● The presence of the IET is to ensure that the report is representative of industry trends which are expected and that the data analysis, and results presented, are independent and authoritative. ● The ‘Main Findings’ section of the report summarises the outcome of the preceding sections of the report.

3.4 Data Capture and Engagement with Supply Chain, Transmission Owners and System Operator

In order to gather a consistent dataset, a suite of RFIs was produced, against which suppliers, contractors, TOs and others were requested to return data. This defined a variety of parameters such as exchange rates and metal rates, with the aim of obtaining comparable data from all parties. They also provided technical details including drawings and assumptions. The RFIs were produced so as to facilitate a “building block” approach to data capture, allowing the various components to be used across different cost build-ups. Separate documents were produced as follows:

- Primary Equipment covering:
 - HVDC Converter Station.
 - Onshore Shunt Reactor.
 - Quadrature Booster.
 - Offshore Reactive Compensation Platform.
 - Offshore Collector Platform.
- Overhead lines with separate documents produced for:
 - Conductors.
 - Optical Fibre Ground Wire.
 - Towers.
 - Glass Insulators.
 - Composite Insulators.
 - Full Turnkey EPC Solution.
 - HTLS Conductor.
- Onshore Cables:
 - Full Turnkey EPC Solution.
 - HVAC and HVDC Cable Systems including cable in tunnel.
- Offshore Cables:
 - Full Turnkey EPC Solution.
 - HVAC and HVDC Cable Systems.

For the following items, a direct approach to specific suppliers was made as it was not considered beneficial to produce a separate specification, due to the nature of the solution and potential data availability:

- GIL.
- Pressurised Air Cable.
- Superconductor.
- Static Series Synchronous Compensator.

The full list of organisations approached is included in Appendix N. This includes organisations currently active in the GB transmission market, including both established companies as well as more recent entrants, and those which were contacted for the 2012 study, where relevant. The list was informed by Mott MacDonald's experience and knowledge of the current market, including known TO framework contractors. In order to maintain the independence of the report, the TOs were engaged in a similar manner as the supply chain and so they also received the RFIs. However, it should be noted that, as explained in Section 2.4, there is some cost data which can only be provided by the TOs, such as development costs, project management costs

and other items such as legal/planning/overheads, etc. Table 3.6 indicates the responses we received to our enquiries.

Table 3.6: Data return rate

Description	Value
Total number of organisations approached	85
Organisations for which no response was received	53
Organisations which responded but were unable to supply data	13
Organisations which were able to supply data	19
Total Response Rate	38%
Total Data Return Rate	22%

As described in Section 2, there is a large amount of activity ongoing in the electricity transmission sector at the present time and, in some instances, this has impacted on the responses received. Table 3.7 provides some commentary as to some of the responses received from each type of organisation. For context, the 2012 study states that 95 organisations were approached with “responses” received from 25 (26% response rate).

Table 3.7: Commentary on responses received

Organisation Type	Commentary
Supply chain including contractors and OEMs	<p>Following engagement with the supply chain, three common forms of response have been received which are summarised below:</p> <ul style="list-style-type: none"> • The supply chain is going through a period of high demand and there are insufficient resources to respond to this enquiry. Some companies are turning down the opportunity to bid for certain projects and are unable to divert staff to providing pricing information for such a study. • Due to the current price volatility (refer to Section 2.4) some companies are not confident about future price levels and are therefore unwilling to contribute to such a study. • Some companies advised that data had been provided to TOs in 2019/2020 when tendering was undertaken for framework contracts. The companies were unwilling to provide data over and above this, and were not prepared to share that data for confidentiality reasons. However, that data has partly informed the information which has been provided to us by the TOs (see below). <p>As a result of the above points, the initial response rate to our enquiries was very low. Following discussion with the TOs and the Project Board, the TOs agreed to assist in encouraging a response, after which the response rate improved.</p>
Transmission Owners	<p>The TOs are resource constrained and are under severe pressure to get a large number of projects through their planning process and ready for construction in order to meet 2030 targets. The resources involved in that process are the same ones which would be able to supply data for this study. Whilst the TOs were able to supply some data, the process took longer than expected, and sometimes it was based on what was available, as opposed to being provided against our RFI.</p>
System Operator	<p>Originally, we were advised to access the system operator via NGET. However, following discussion with the Project Board and the TOs, it is understood that any data held by the system operator would likely be based on what has been supplied by the TOs. As such, no additional engagement with the system operator has been undertaken to inform the cost assessment.</p>

In general, the approach taken was to initially engage with suppliers via email and follow up with virtual meetings for those suppliers which were responsive. A large amount of time and effort was expended in an effort to obtain as much data as possible. Where responses were not received initially, alternative points of contact were sought either from within the business, or

from wider contacts including the IET Project Board. Meetings were also held with each of the TOs. A template was provided for data responses and a technical query form was provided to allow clarifications regarding our enquiry. Further details on the type and quantity of data received, and how this has been used, are provided in Section 4 of this report.

Following analysis of the quantity of data received, it was identified that in some areas it was not sufficient to undertake the required level of analysis. As a result, a greater effort was placed in those areas on obtaining data from the public domain. Large quantities of information were gathered from sources such as contract award publications, Ofgem assessments and others. Further information as to how this has been used is provided in Section 4 of this report.

4 Cost and Ratings Assessment

4.1 Introduction

This section of our report presents the cost and ratings assessment for the different technologies. The approach we have taken is detailed further in Appendix C and uses either data we have obtained from the supply chain or TOs, or publicly available information. The technologies, ratings and circuit lengths which are to be considered are described in Section 3 of this report.

As highlighted elsewhere in this report, the costs presented do not reflect the actual cost which will be incurred for a given scenario. The only way to achieve cost certainty for a particular project is to fully define it and award a contract for construction and, even then, it is likely that costs will vary during project execution. The cost estimates presented in this report are intended to allow a relative comparison between the different technologies, by providing an estimate based on common parameters. The actual cost will vary on a project-by-project basis. Some costs have been estimated based on derivation from other data sources due to no relevant project data being available. In this instance the level of cost certainty is somewhat lower than for other cases. For reasons of transparency, the data presented throughout this section of the report provides an indication of the data source and uses the following colour coding:

- Data Source:
 - **supply chain and TO data**
 - **public domain information or limited set of TO data**
 - **derivation from one of the above**

Table 4.1: Basis of Cost and Ratings Assessment

Description of Technology	Ratings Considered (per circuit)	Lengths Considered	Cost Basis
Onshore Technologies – Costed on the basis of a double circuit installation			
400 kV Overhead Line	● High: 3,741 MVA	● 3 km	● Cost assessment undertaken on the basis of TO and supply chain data . ● Each combination of rating and circuit length has been considered, so nine data-sets in total.
	● Medium: 2,494 MVA	● 15 km	
	● Low: 1,247 MVA	● 75 km	
400 kV Underground Cable – Direct Buried	● High: 3,741 MVA	● 3 km	● Cost Assessment undertaken on the basis of TO and supply chain data . ● Each combination of rating and circuit length has been considered, so nine data-sets in total.
	● Medium: 2,494 MVA	● 15 km	
	● Low: 1,247 MVA	● 75 km	
400 kV Underground Cable – in Tunnel	● High: 3,741 MVA	● 3 km	● Cost Assessment undertaken on the basis of TO and public domain data . ● Each combination of rating and circuit length has been considered, so nine data-sets in total.
	● Medium: 2,494 MVA	● 15 km	
	● Low: 1,247 MVA	● 75 km	
Offshore Technologies – Costed on the basis of an onshore-offshore radial link			
275 kV HVAC Submarine Cable (onshore-offshore radial link)	● High: 2,000 MW	● 90 km	● Cost Assessment undertaken on the basis of public domain data . ● Each combination of rating and circuit length has been considered, so nine data-sets in total.
	● Medium: 1,000 MW	● 180 km	
	● Low: 500 MW	● 275 km	
HVDC Voltage Sourced Converter (onshore-offshore radial link)	● High: 2,000 MW	● 90 km	● Cost Assessment undertaken on the basis of public domain data . ● Each combination of rating and circuit length has been considered, so nine data-sets in total.
	● Medium: 1,000 MW	● 180 km	
	● Low: 500 MW	● 275 km	

Description of Technology	Ratings Considered (per circuit)	Lengths Considered	Cost Basis
HVDC Voltage Sourced Converter (onshore-onshore “embedded link”)	<ul style="list-style-type: none"> High: 2 GW 	<ul style="list-style-type: none"> 90 km 180 km 275 km 	<ul style="list-style-type: none"> Cost Assessment undertaken on the basis of public domain data. Single rating considered over three lengths.
Alternative Technologies			
Gas-insulated Line	<ul style="list-style-type: none"> N/A 	<ul style="list-style-type: none"> N/A 	<ul style="list-style-type: none"> This option has not been costed for the following reasons: <ul style="list-style-type: none"> It has not been possible to obtain data to allow a meaningful assessment to take place. GIL requires a significant quantity of SF6, which the TOs are moving away from using. From discussions with the TOs we understand that none of them currently plan to use this technology outside of a substation environment.
Pressurised Air Cable	<ul style="list-style-type: none"> 2.334 GW 	<ul style="list-style-type: none"> 3 km 15 km 75 km 	<ul style="list-style-type: none"> As this is an emerging technology, no cost data is available from actual projects. We have obtained pricing data from a supplier for materials, and have estimated installation costs based on the cost of installing underground cables. We have also estimated the cost of a monitoring system. Comparatively lower level of cost certainty as a result of the above approach.
Superconducting Cable	<ul style="list-style-type: none"> 1.371 GW 	<ul style="list-style-type: none"> 3 km 15 km 75 km 	<ul style="list-style-type: none"> As this is an emerging technology, no cost data is available from actual projects. We have estimated material costs based on public domain information, and have estimated installation costs based on them being similar to those of underground cables, with an additional allowance for the cooling system. Whilst losses associated with the cable system are expected to be negligible, we have made an estimate as to the losses which could be expected to arise from the cooling system. Comparatively lower level of cost certainty.
Multi-terminal HVDC	<ul style="list-style-type: none"> 2 GW 	<ul style="list-style-type: none"> 2x180 km circuits 	<ul style="list-style-type: none"> Due to the limited application of this technology to date, supply chain and public domain information are not available. However, an indicative estimate has been undertaken, using the public domain information obtained for the HVDC VSC options.
Reconductoring of existing medium rated OHL	<ul style="list-style-type: none"> Additional Capacity of 1,247 MW per circuit 	<ul style="list-style-type: none"> 75 km 	<ul style="list-style-type: none"> A limited pool of TO data has been made available which has allowed us to indicate a typical “per km” price range which could be expected. We have estimated the additional capacity which could be achieved and provided an indication of lifetime costs on that basis.
Alternative Tower Technologies – T-pylons	<ul style="list-style-type: none"> 2,494 MW per circuit 	<ul style="list-style-type: none"> 15 km 75 km 	<ul style="list-style-type: none"> Cost Assessment undertaken on the basis of TO and public domain data.
Quadrature Booster	<ul style="list-style-type: none"> 2,750 MVA 	<ul style="list-style-type: none"> N/A 	<ul style="list-style-type: none"> A single data-source has been provided in respect of this technology. To protect data anonymity we have provided an indicative range in respect of the build cost. As the amount of additional capacity which can be provided is application specific a £/MWkm value has not been calculated.

Description of Technology	Ratings Considered (per circuit)	Lengths Considered	Cost Basis
Series Capacitor	● N/A	● N/A	● It has not been possible to obtain data for this technology and therefore no cost assessment is provided.
Static Series Synchronous Compensator	● N/A	● N/A	<ul style="list-style-type: none"> ● A limited data set has been provided by a TO and a supplier. ● To protect data anonymity we have provided an indicative range in respect of the build cost for a “typical” installation. ● As the amount of additional capacity which can be provided is application specific, a £/MWkm value has not been calculated.
Onshore HVDC VSC	● 2 GW	● 700 km	● Cost Assessment undertaken on the basis of public domain data.
Onshore HVDC LCC	● 8 GW	● 700 km	<ul style="list-style-type: none"> ● Public domain data in respect of this technology is not readily available. ● Our estimate assumes that towers and foundations are similar to those of a 765 kV a.c. line (see below) ● Comparatively lower level of cost certainty.
UHV Onshore a.c. Transmission	● 8 GW	● 700 km	<ul style="list-style-type: none"> ● Cost of point to point single circuit 765 kV OHL, with associated a.c. infrastructure at each end. ● Public domain data in respect of this technology is not readily available. ● We have undertaken an estimate based on our experience of other similar projects. ● Comparatively lower level of cost certainty.

4.2 Presentation of Data

The following sections present the whole life cost assessments which include fixed build costs, variable build costs and variable operating costs. A description of the different cost components which are included in these categories is provided in Section C.2.5. For each case assessed, we have presented the output data from the cost and ratings assessment on a single page as follows:

- Data source used for estimating.
- Headline figures for lifetime cost, broken down as follows:
 - Build cost: fixed and variable, including any reactive compensation equipment if applicable.
 - Operating cost: losses and O&M.
- Lifetime cost in £/km, incorporating both the build and operating cost over the lifetime of the asset.
- Lifetime Power Transfer Cost in £/MWkm:
 - This considers both the lifetime cost for the particular technology, but also the transfer capacity which is created.
 - Dividing the cost by the design power transfer capacity of the asset and the route length provides a lifetime “power transfer cost” (£/MWkm) and enables a like-for-like comparison of each technology across all the different ratings and lengths which have been studied.
- Pie charts including:
 - Overall build cost.
 - Lifetime cost.

- For instances where the cost assessment has been undertaken based on publicly available information, or by derivation, it may be that insufficient data is available to provide a breakdown of fixed and variable costs. In these instances, a single pie chart is presented detailing the overall cost build-up.

Also provided are a selection of sensitivities, i.e., an analysis showing the impact an adjustment to a selection of factors can have on the final cost. These are described in more detail in Section C.2.2. An example is provided in Figure 4.1. A number of sensitivity headings are shown on the left-hand side, each of which has three cases listed. The middle case is the baseline that was used to produce the overall cost listed in that option assessment. Case A and Case B meanwhile provide alternatives, with the chart illustrating the associated change in overall lifetime cost.

Compared to the baseline, Case A is generally more favourable and Case B is generally more adverse, although this is not the case for all of the sensitivities examined. Taking route length in the example below, the baseline case would be 15 km, while Case A considers the difference in cost if the route length was only 7.5 km, providing a reduction in overall costs of 21.7%. Conversely, if the route length was increased by 50% as in Case B, the overall cost would be 18.7% greater than the baseline.

Figure 4.1: Sensitivity example, Overhead Line 15 km Medium Rating.

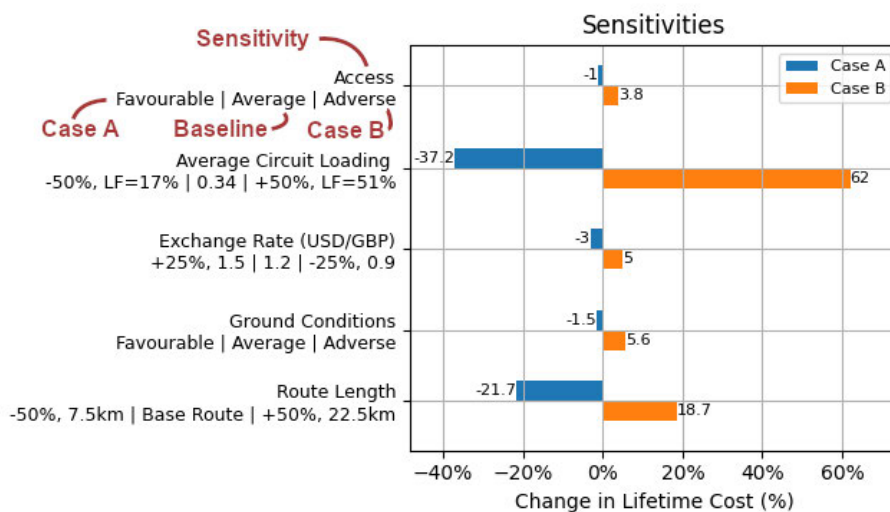

After all the combinations of cases are presented for each technology, a set of bar charts is then provided which summarise the build cost, lifetime cost per km and lifetime power transfer cost, for ease of comparison, along with a written summary.

4.3 Whole Life Cost Assessments

The cost assessments are presented in the following charts. The methodology for undertaking the cost assessments is explained in Appendix C; the following high-level points are to be noted:

- The costs are presented as 2023 figures.
- Where historical data has been used as part of the calculation, exchange rate and inflation factors have been applied to bring it to present day terms.
- For costs which are expected to occur in the future (e.g., O&M costs), a discount rate has been applied to bring these to present day terms.

- O&M costs have been calculated on a “percentage of CAPEX” basis as explained in Appendix C.
- Losses have been calculated in Appendix I and a fixed rate of £50/MWh has been assumed.
- The calculations are for the specific scenarios, circuit ratings and lengths stated. The reader should note in particular that the low/medium/high underground cable solutions are based on either one, two or three 2,500 mm² conductors per phase, respectively. However, for the solution in a tunnel, the high rating can still be achieved with only two conductors per phase.
- For the solution in a tunnel, the low rating is based on a 3m diameter tunnel, whereas the medium and high ratings are based on a 4m diameter tunnel.
- As explained in Appendix I, for the purposes of calculating losses, the average circuit load on the onshore transmission system is assumed to be 34%²⁷ of winter post fault continuous capacity of the circuit. We have not identified a suitable data source in respect of the loading of offshore transmission assets, which are used in a different way to the onshore transmission system. For comparison purposes, calculation of losses for the offshore technologies assumes the assets are operating at full capacity. It is recognised that in practice this will only be true for a small proportion of the operational time and therefore a sensitivity has been provided in the cost analysis indicating the potential impact of using 34% and 50% loadings.
- For HVDC cases, the fixed costs comprise the converter stations and substation assets (including offshore platforms if applicable), and the variable costs comprise the HVDC cable system

²⁷ NGET_A11.11 Transmission Loss Strategy,” National Grid, Dec. 2019. [Online]. Available: <https://www.nationalgrid.com/electricity-transmission/document/132276/download>

Overhead Line – 3 km – Low Rating (2,494 MW)

Lifetime Cost
£11.16m

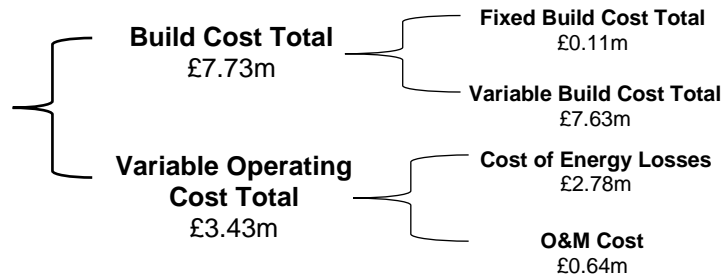

Lifetime Cost per km	£3.72m/km
Lifetime Power Transfer Cost per km	£1,492/MWkm

Data Source: [TO and supply chain data](#)

Build Costs (£7.74m)

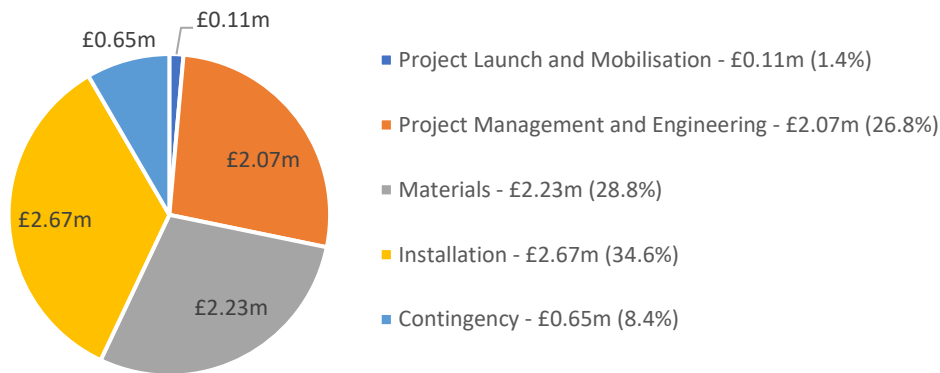

Total Cost (£11.16m)

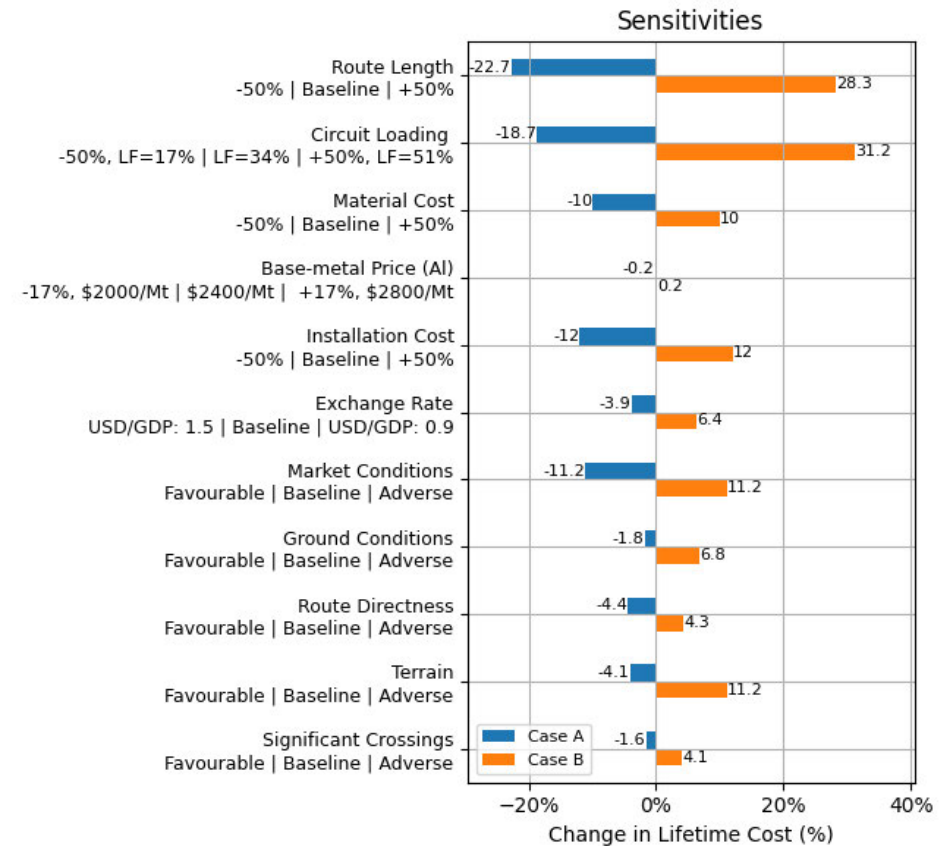
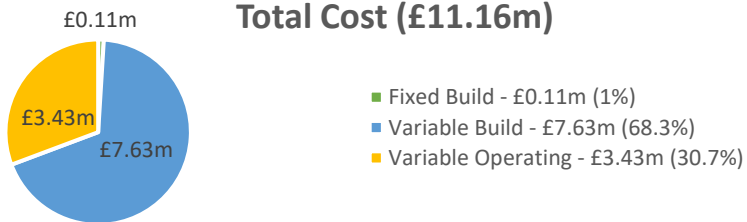

Overhead Line – 3 km – Medium Rating (4,988 MW)

Lifetime Cost
£17.90m

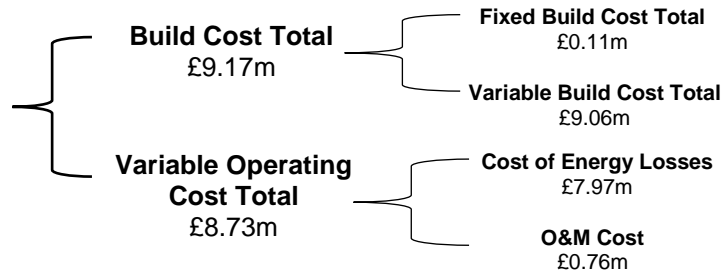

Lifetime Cost per km	£5.97m/km
Lifetime Power Transfer Cost per km	£1,196/MWkm

Data Source: TO and supply chain data

Build Costs (£9.17m)

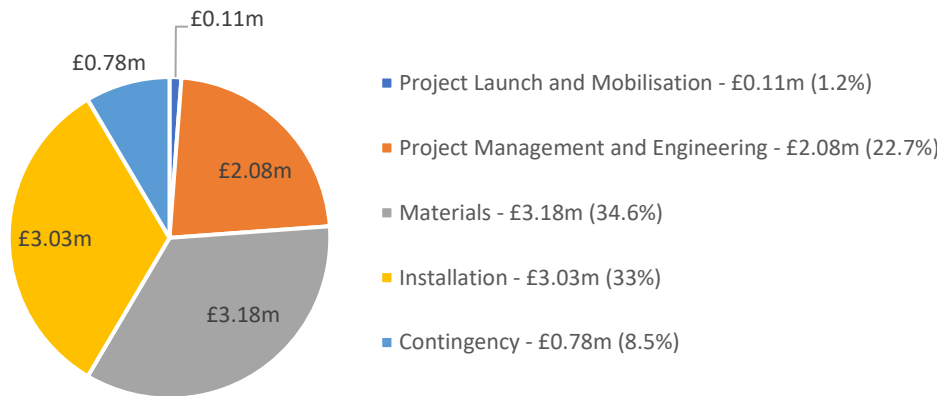

Total Cost (£17.9m)

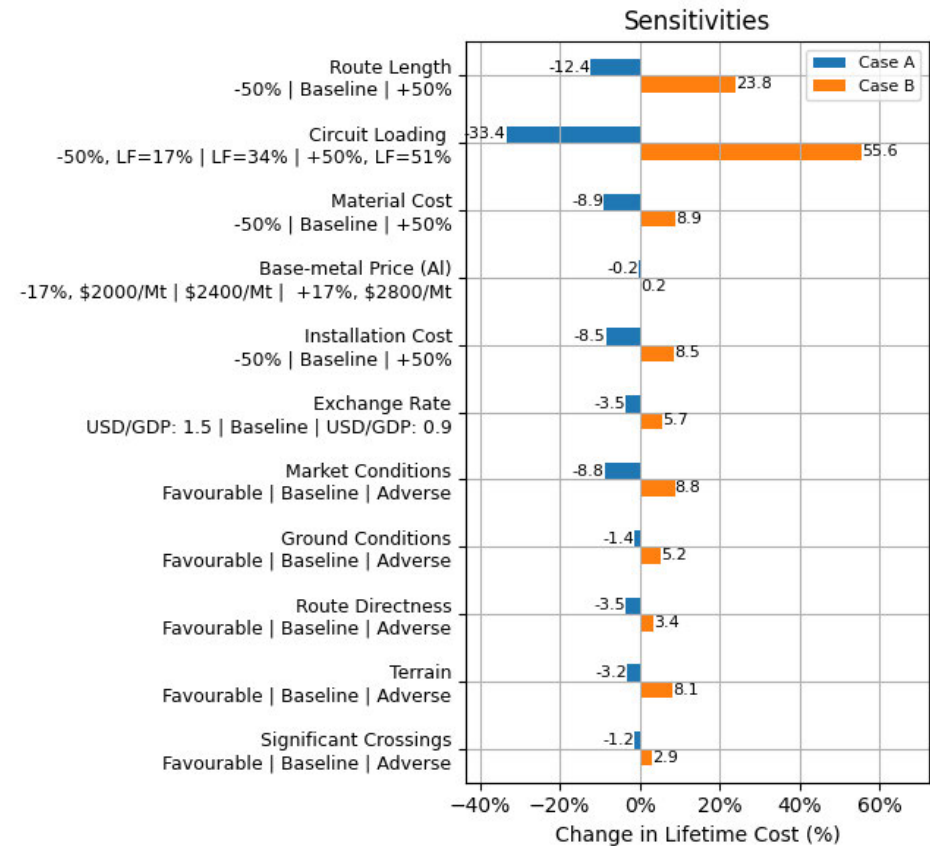
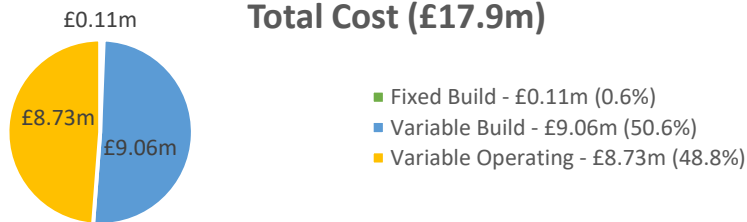

Overhead Line – 3 km – High Rating (7,482 MW)

Lifetime Cost
£27.61m

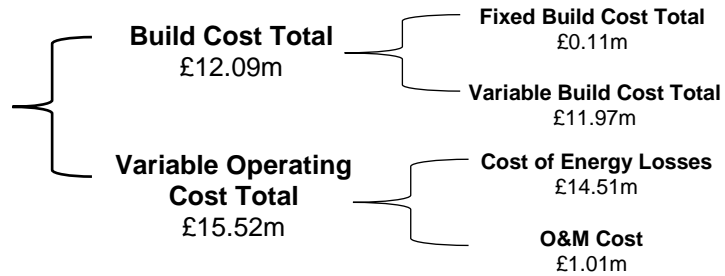

Lifetime Cost per km	£9.20m/km
Lifetime Power Transfer Cost per km	£1,230/MWkm

Data Source: TO and supply chain data

Build Costs (£12.09m)

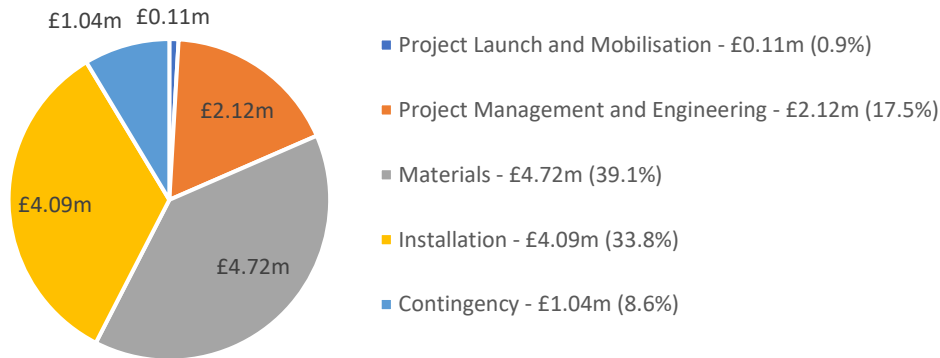

Total Cost (£27.6m)

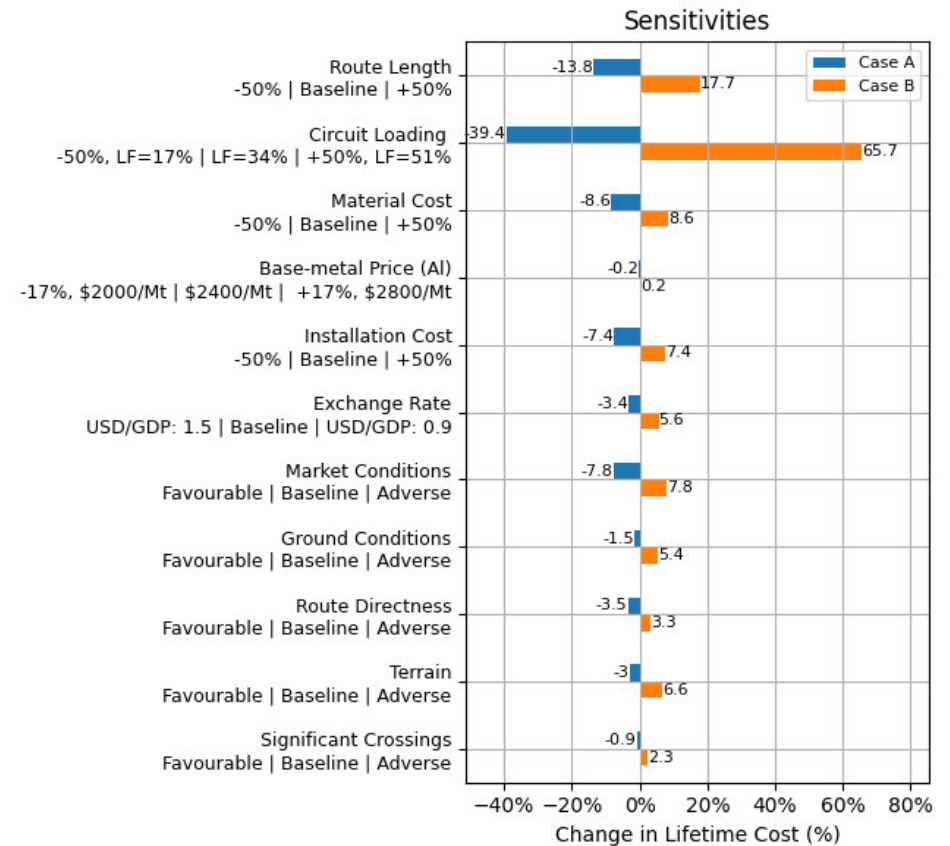
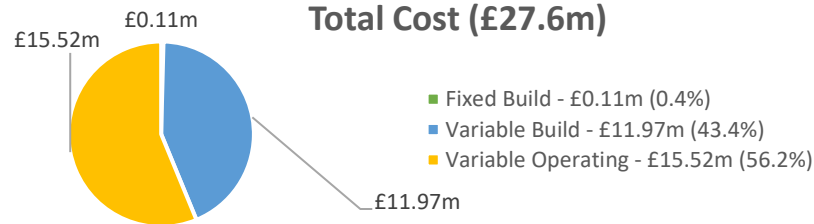

Overhead Line – 15 km – Low Rating (2,494 MW)

Lifetime Cost
£47.73m

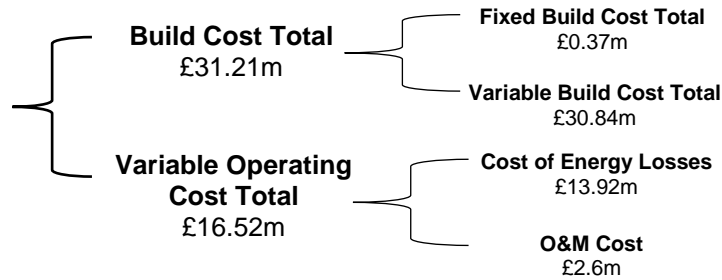

Lifetime Cost per km	£3.18m/km
Lifetime Power Transfer Cost per km	£1,276/MWkm

Data Source: [TO and supply chain data](#)

Build Costs (£31.21m)

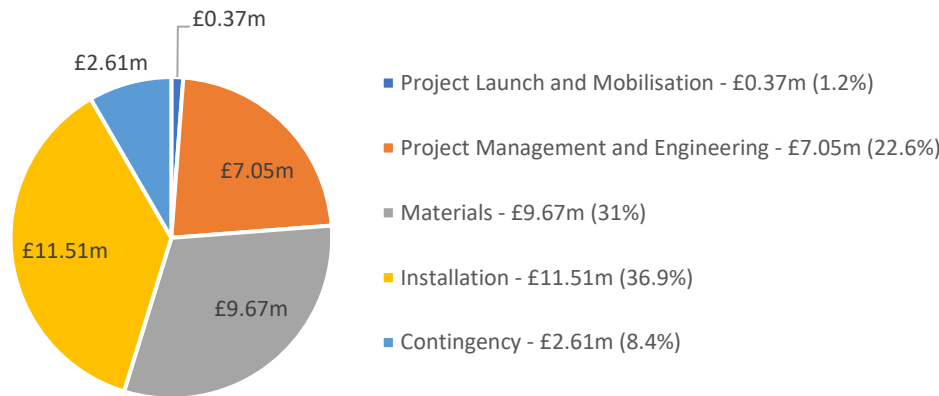

Total Cost (£47.73m)

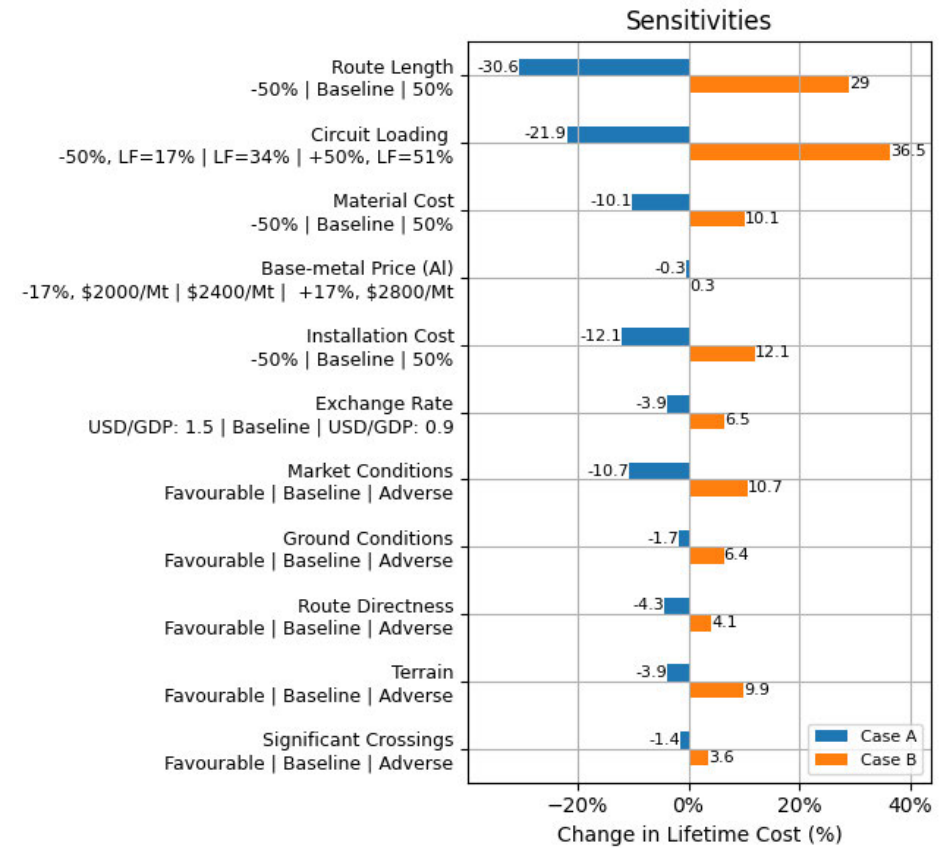
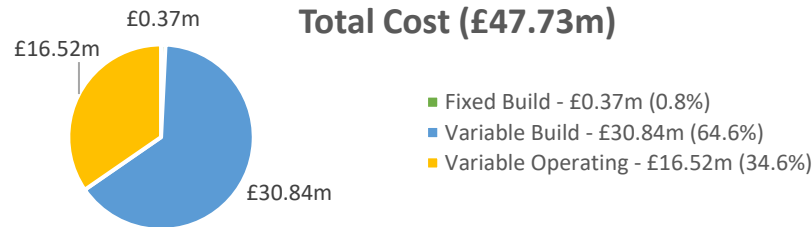

Overhead Line – 15 km – Medium Rating (4,988 MW)

Lifetime Cost
£80.30m

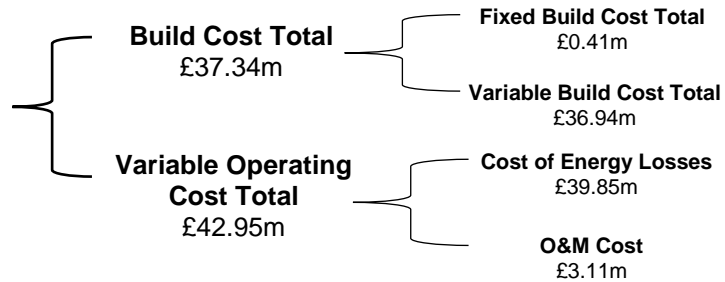

Lifetime Cost per km	£5.35m/km
Lifetime Power Transfer Cost per km	£1,073/MWkm

Data Source: TO and supply chain data

Build Costs (£37.34m)

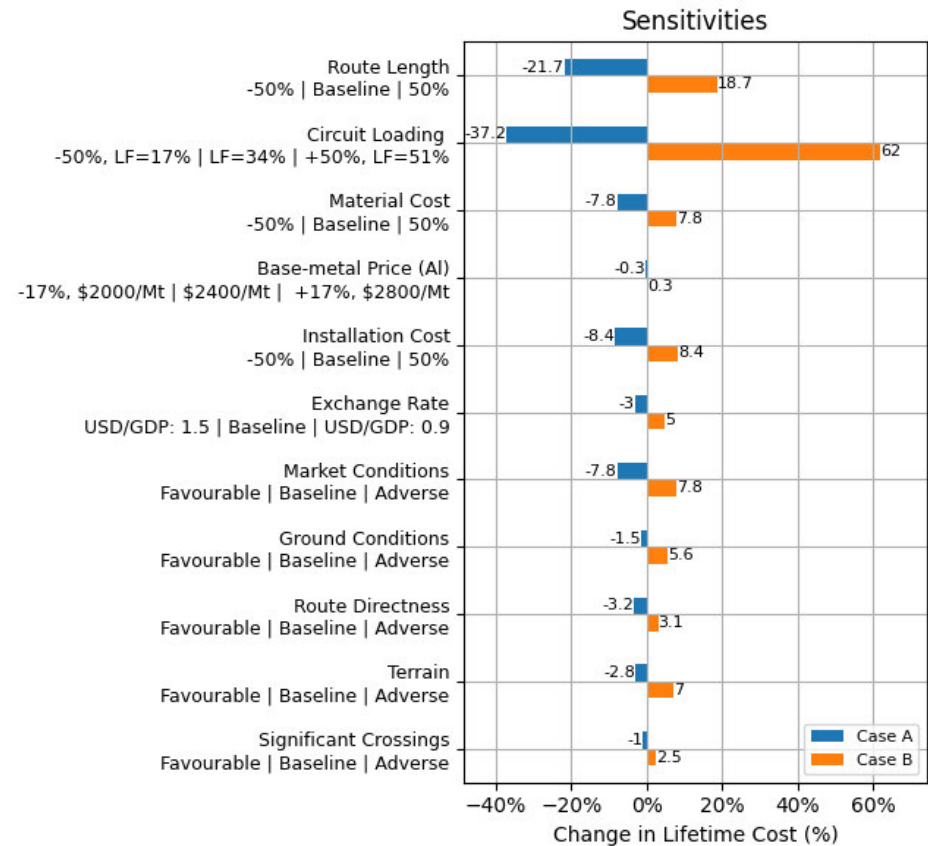
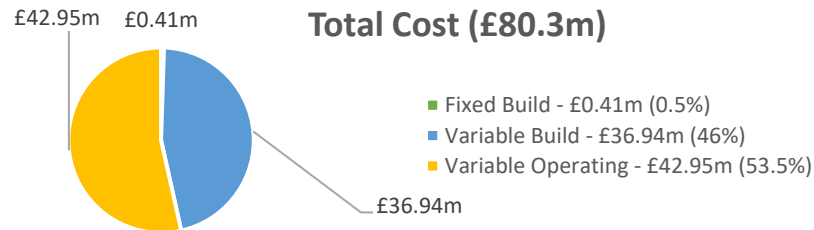
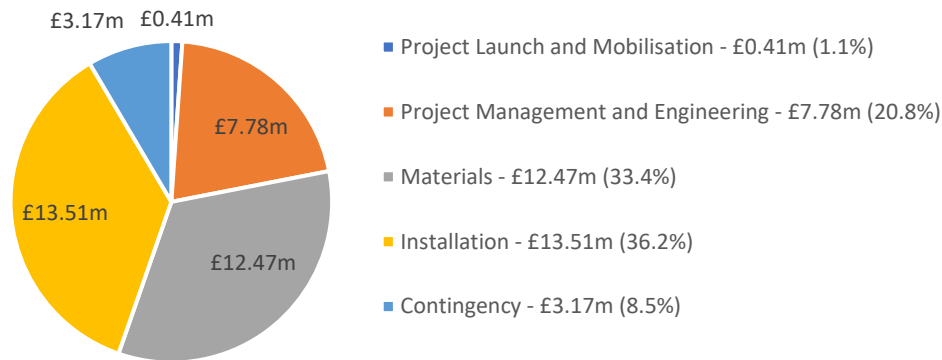

Overhead Line – 15 km – High Rating (7,482 MW)

Lifetime Cost
£124.60m

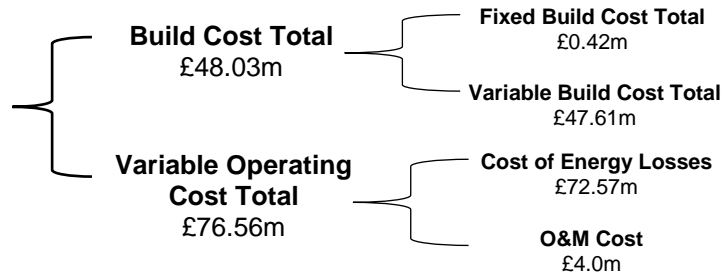

Lifetime Cost per km	£8.31m/km
Lifetime Power Transfer Cost per km	£1,110/MWkm

Data Source: TO and supply chain data

Build Costs (£48.03m)

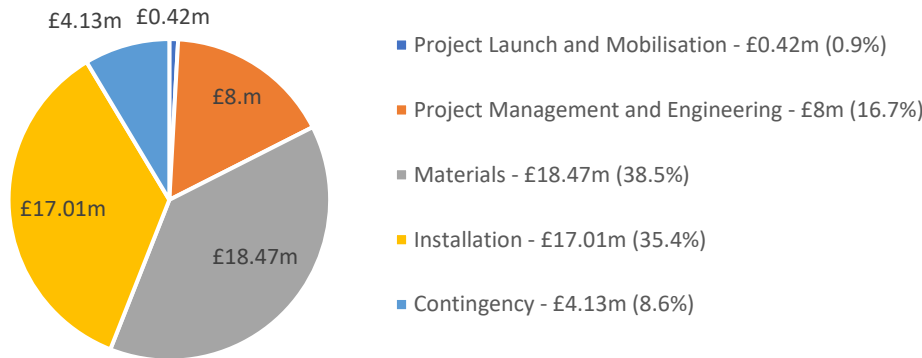

Total Cost (£124.6m)

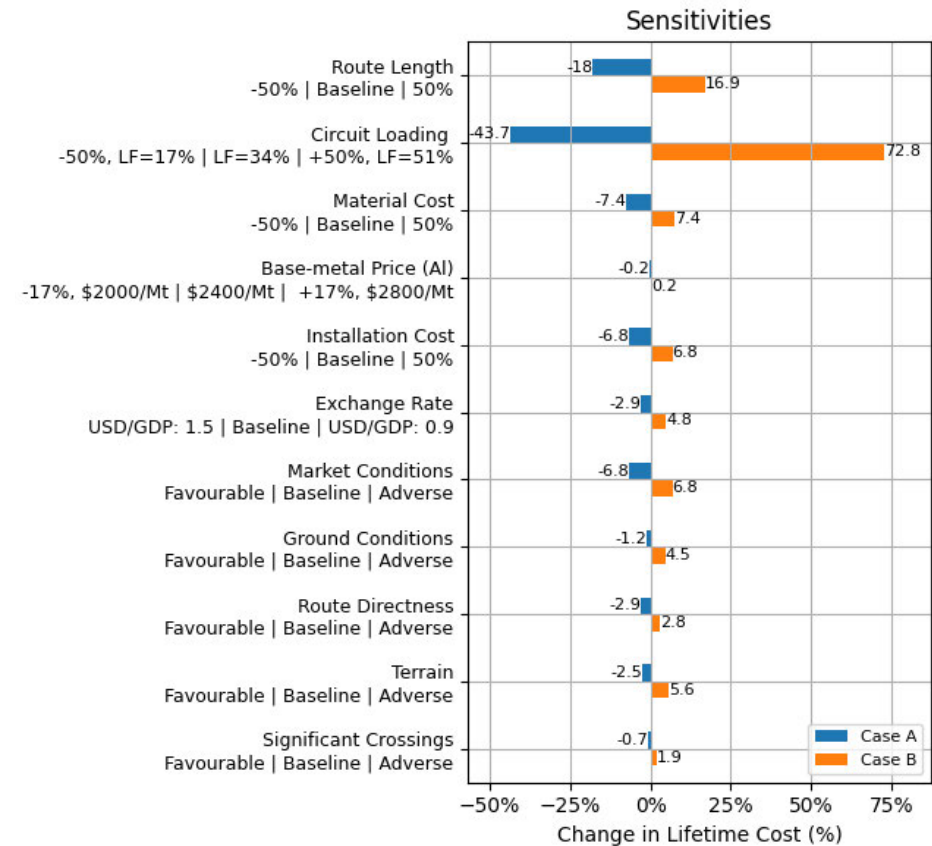
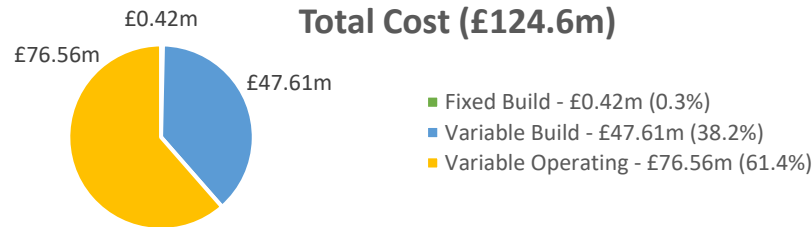

Overhead Line – 75 km – Low Rating (2,494 MW)

Lifetime Cost
£226.36m

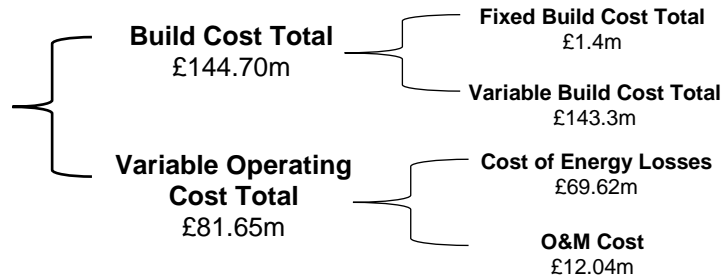

Lifetime Cost per km	£3.02m/km
Lifetime Power Transfer Cost per km	£1,210/MWkm

Data Source: TO and supply chain data

Build Costs (£144.7m)

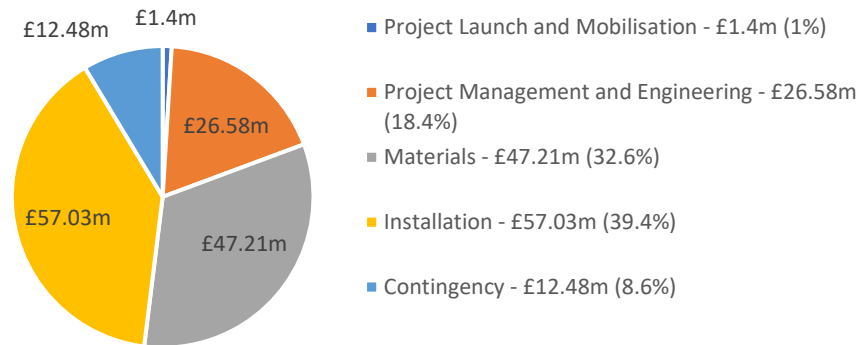

Total Cost (£226.36m)

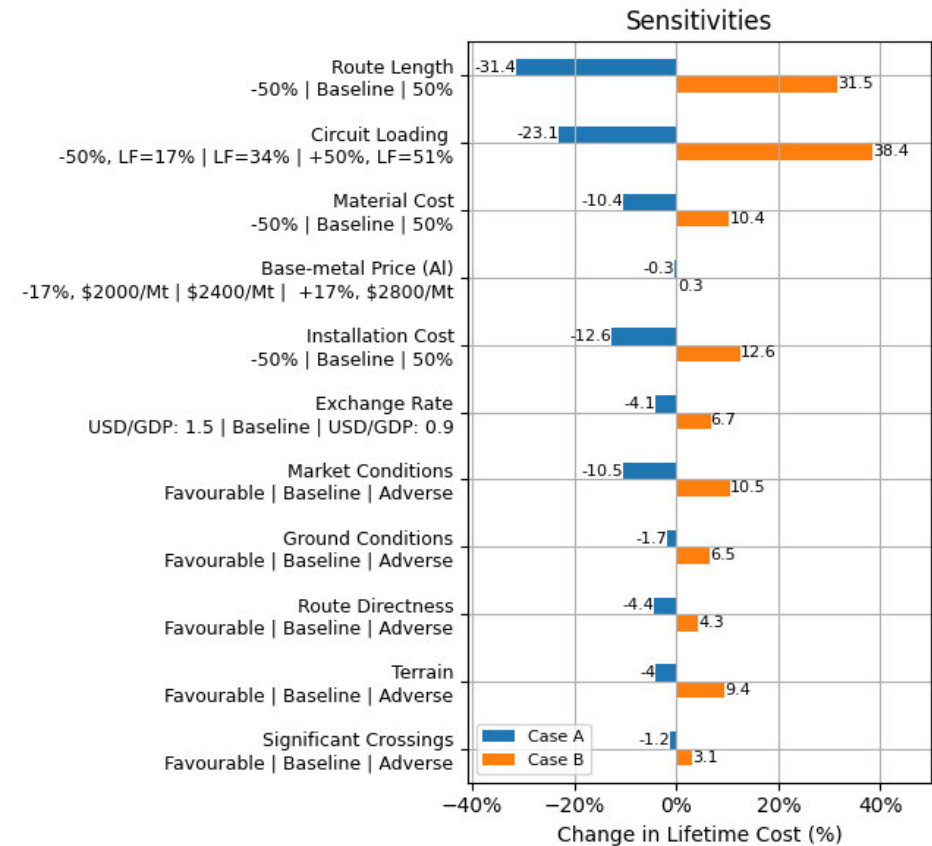
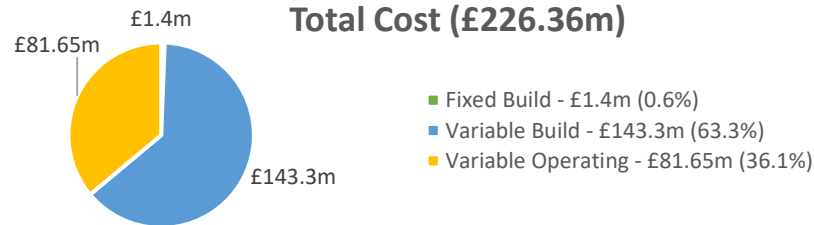

Overhead Line – 75 km – Med Rating (4,988 MW)

Lifetime Cost
£378.64m

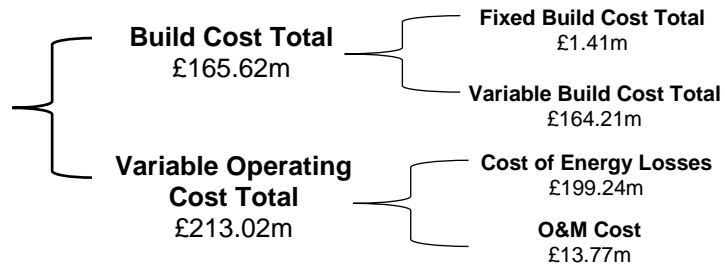

Lifetime Cost per km	£5.05m/km
Lifetime Power Transfer Cost per km	£1,012/MWkm

Data Source: TO and supply chain data

Build Costs (£165.62m)

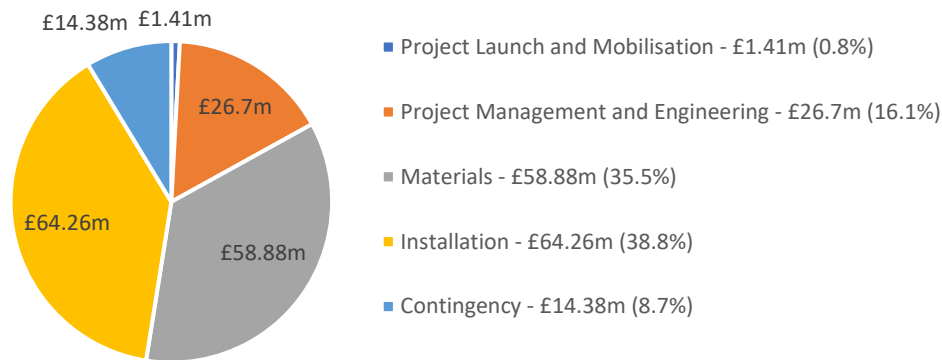

Total Cost (£378.64m)

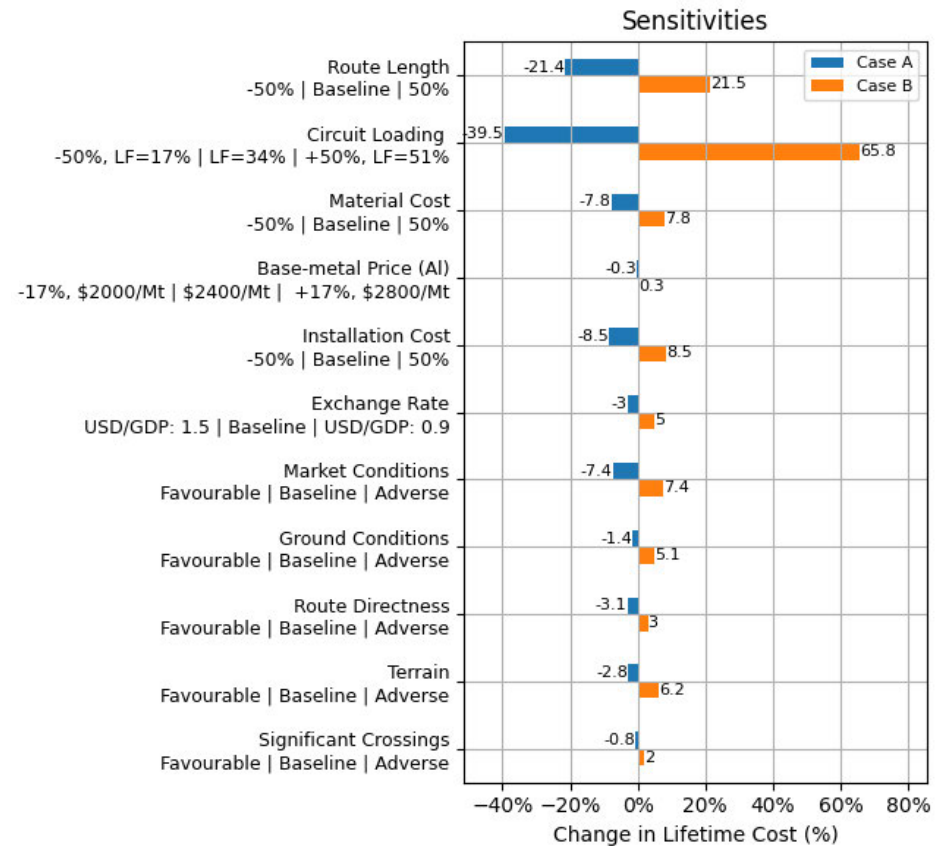
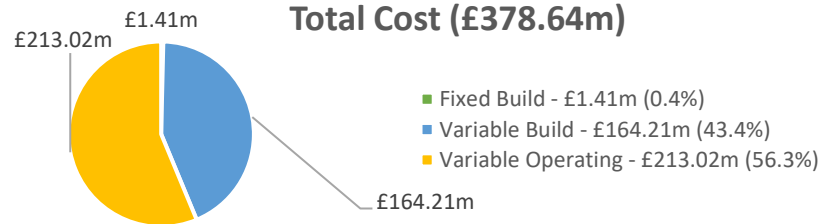

Overhead Line – 75 km – High Rating (7,482 MW)

Lifetime Cost
£602.40m

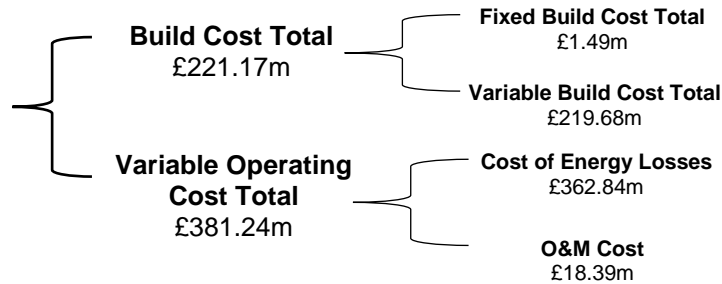

Lifetime Cost per km	£8.03m/km
Lifetime Power Transfer Cost per km	£1,074/MWkm

Data Source: TO and supply chain data

Build Costs (£221.17m)

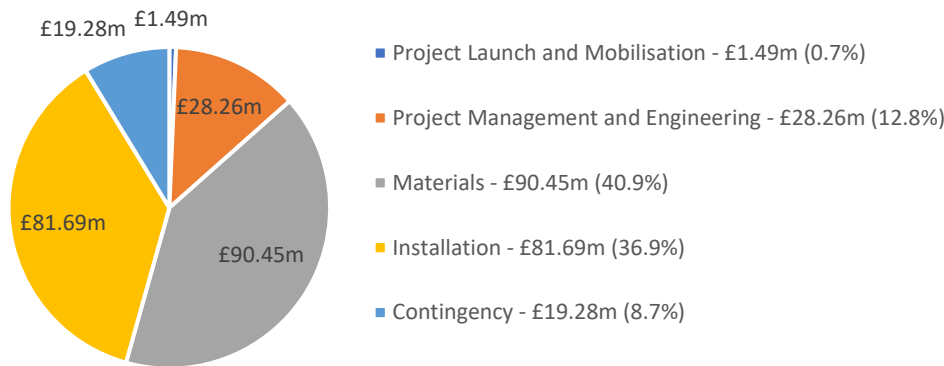

Total Cost (£602.4m)

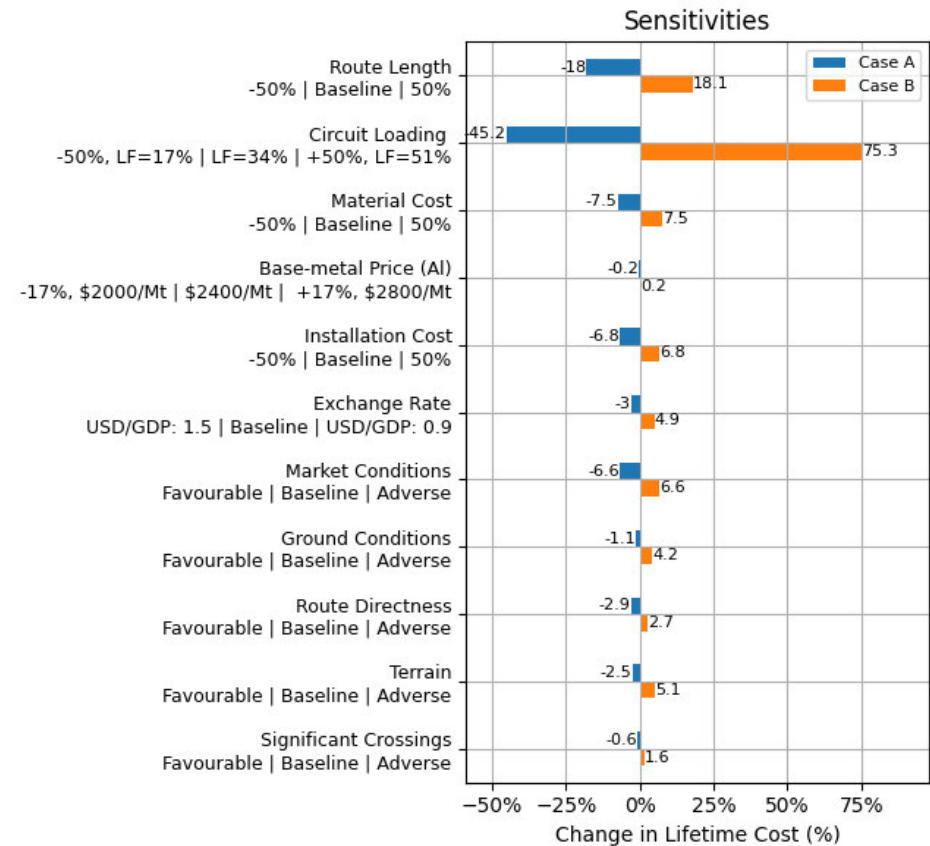
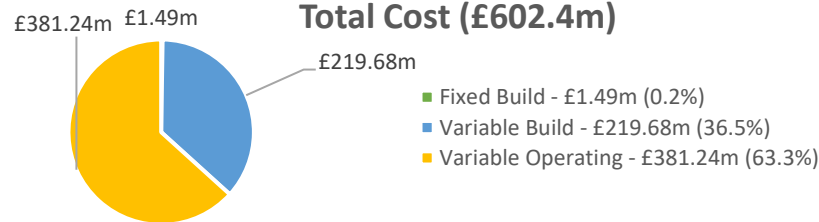

OHL Lifetime Cost

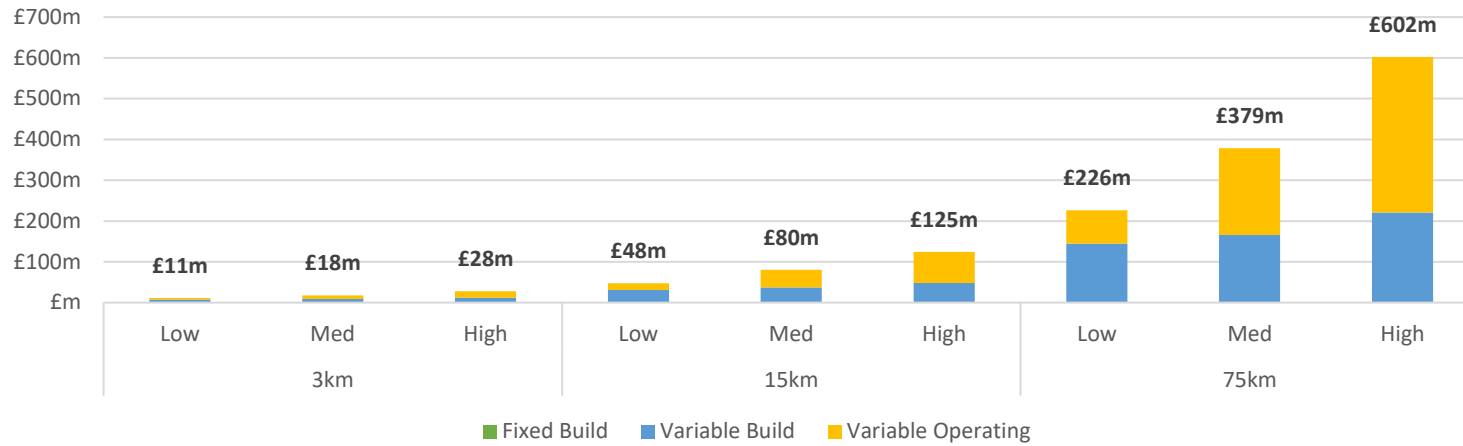

OHL Lifetime Cost/km

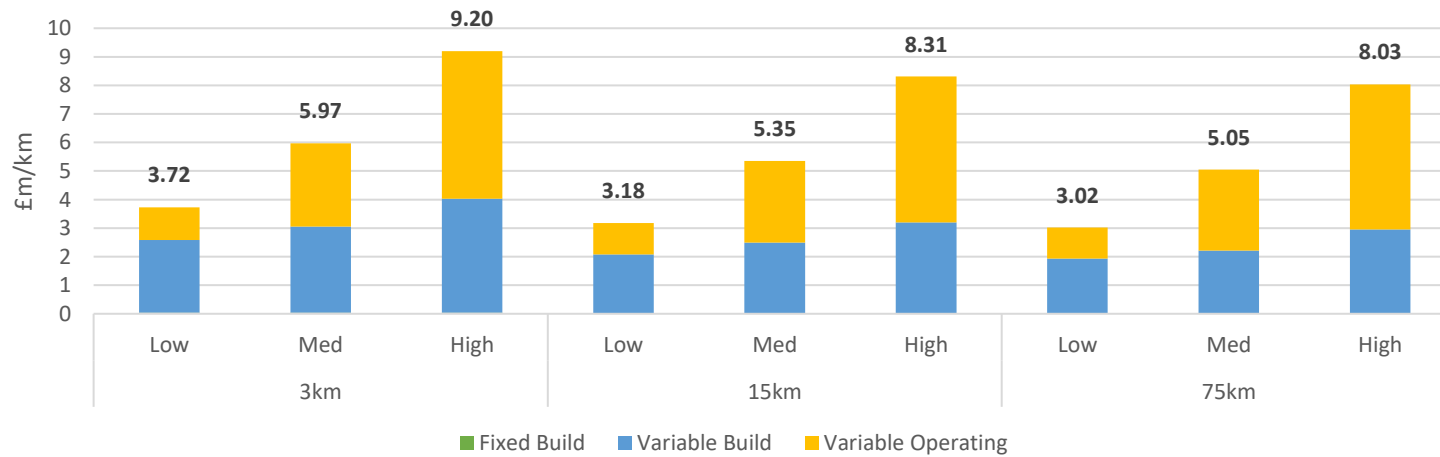

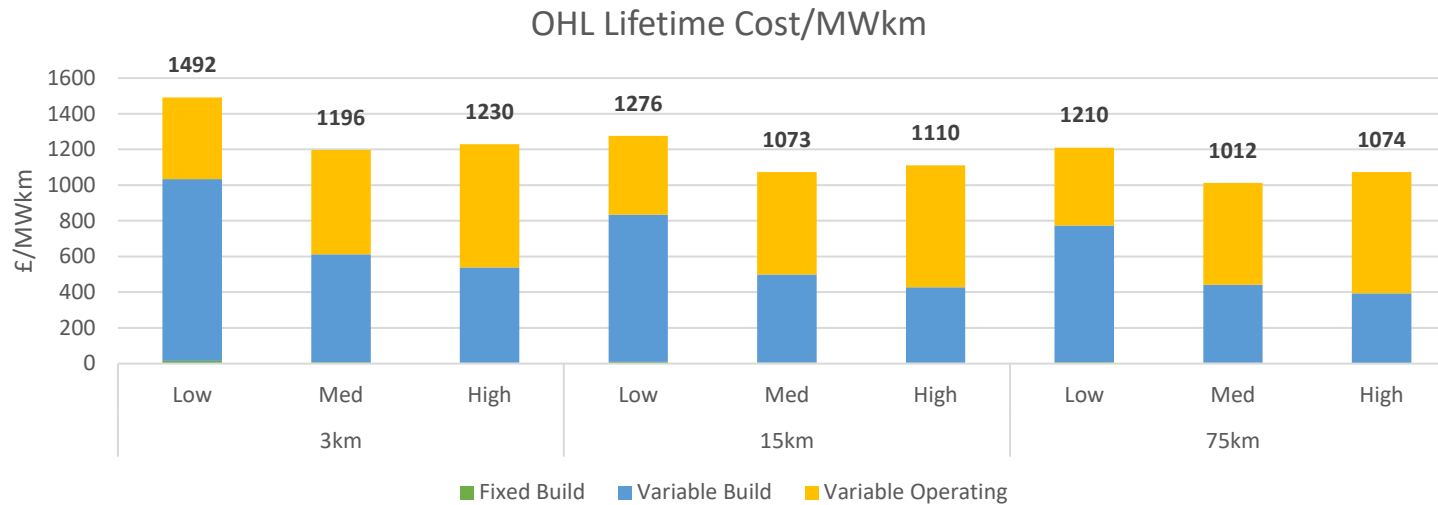

From the figures above we can see that the ratio of lifetime cost between medium and low, and high and medium ratings, is between 1.5 and 1.7, that is the medium rated construction is around 1.5 to 1.7 times the cost of the low, and the same applies for high and medium. However, when the amount of power which is transferred is considered it shows that the low rated route is the most expensive, with the medium and high rated routes being very similar. The reason that the medium and high are similar is that, whilst construction costs are marginally lower for a high rated system, the operating costs are higher, with the dominant factor being the losses. Whilst a high rated route has a lower resistance than the medium rated route, the current which is carried is 50% higher. As the losses increase with the square of the current, the reduction in resistance achieved is not sufficient to offset this

Underground Cable Buried – 3 km – Low Rating (2,494 MW)

Lifetime Cost
£50.13m

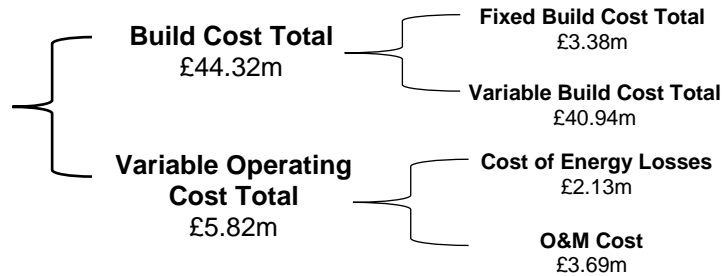

Lifetime Cost per km	£16.71m/km
Lifetime Power Transfer Cost per km	£6,700/MWkm

Data Source: TO and supply chain data

Build Costs (£44.32m)

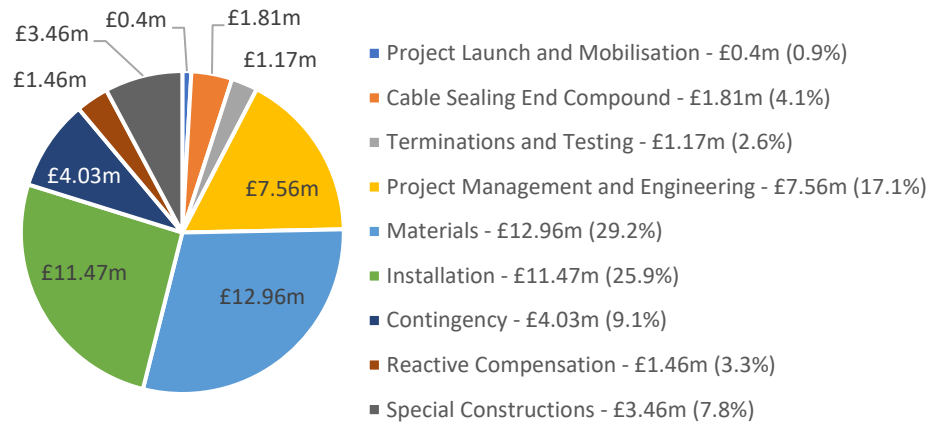

Total Cost (£50.13m)

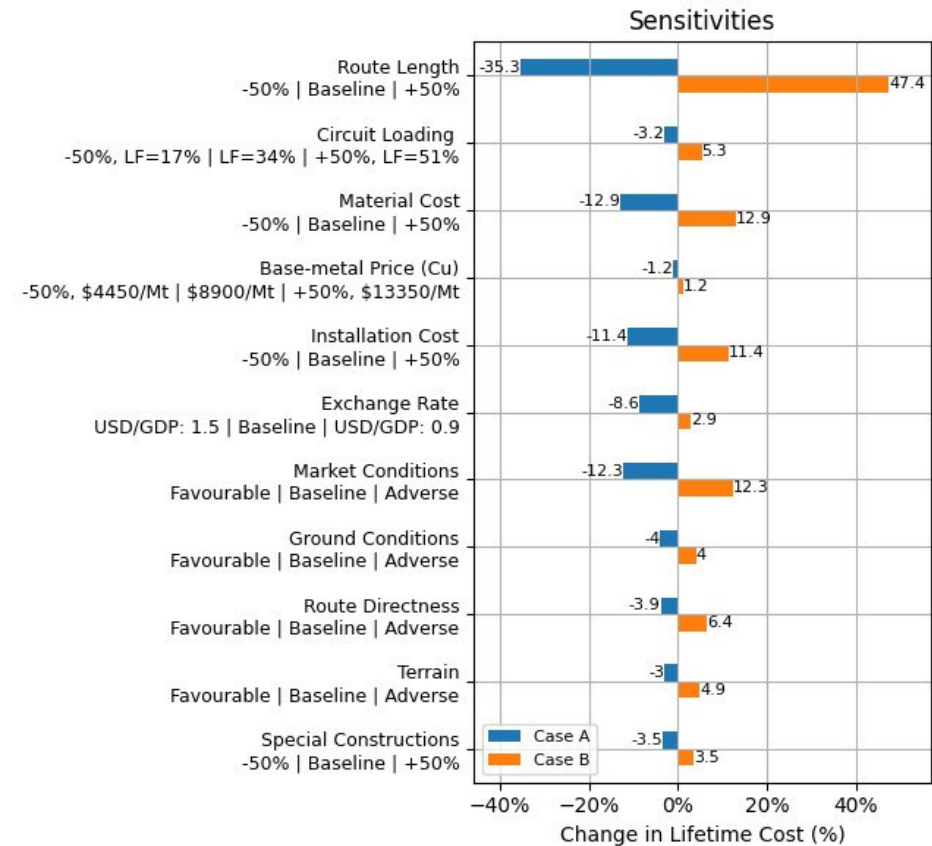
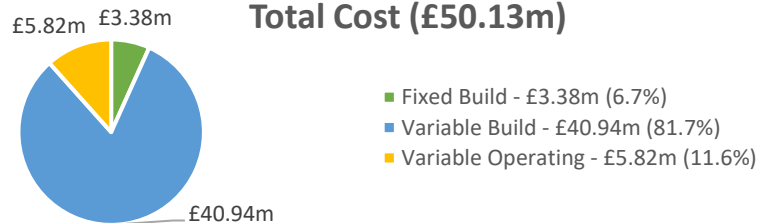

Underground Cable Buried – 3 km – Medium Rating (4,988 MW)

Lifetime Cost
£84.24m

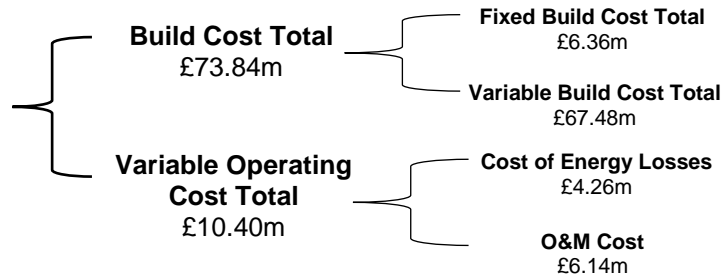

Lifetime Cost per km	£28.08m/km
Lifetime Power Transfer Cost per km	£5,629/MWkm

Data Source: TO and supply chain data

Build Costs (£73.84m)

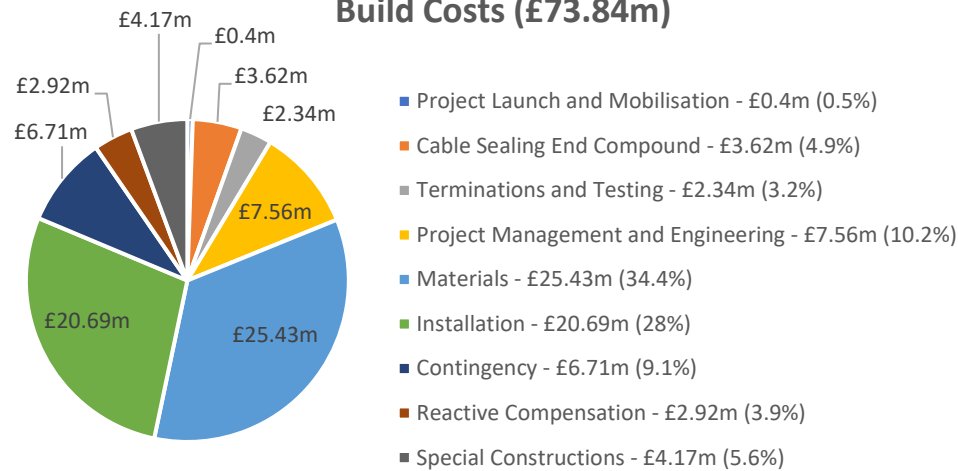

Total Cost (£84.24m)

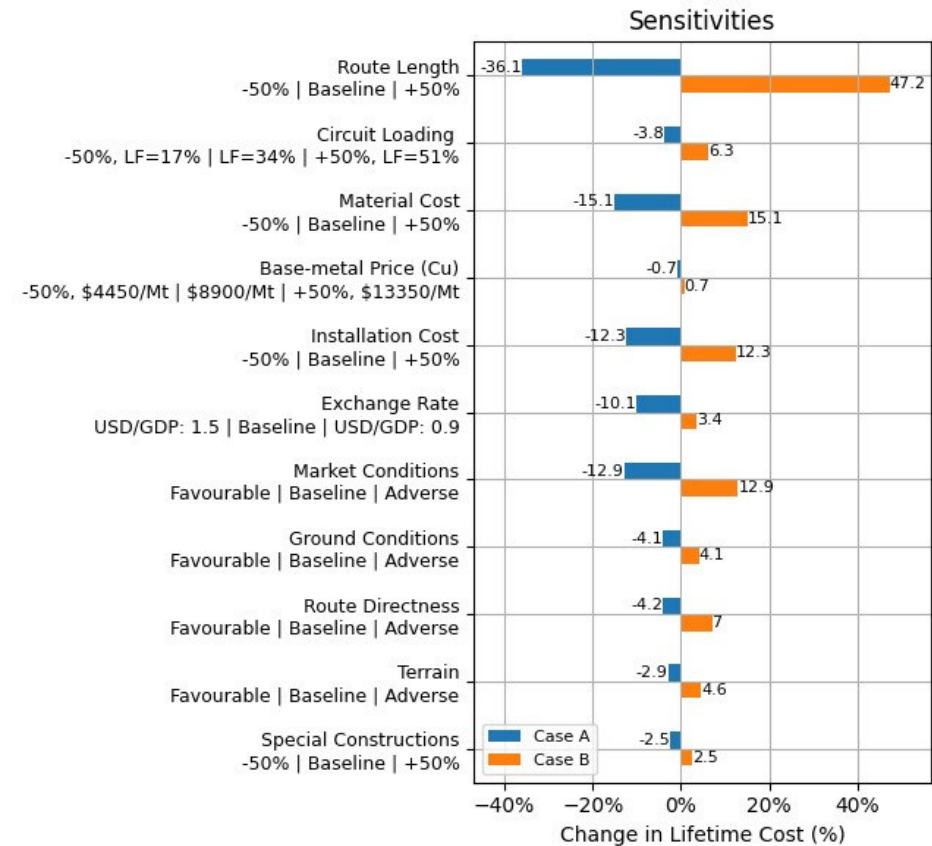
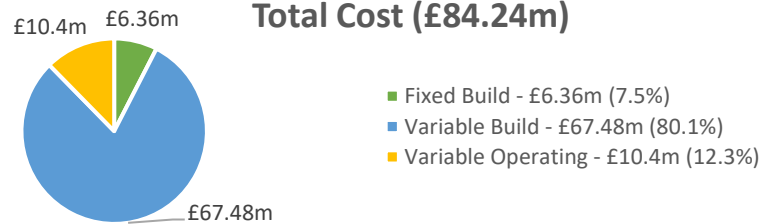

Underground Cable Buried – 3 km – High Rating (7,482 MW)

Lifetime Cost
£117.97m

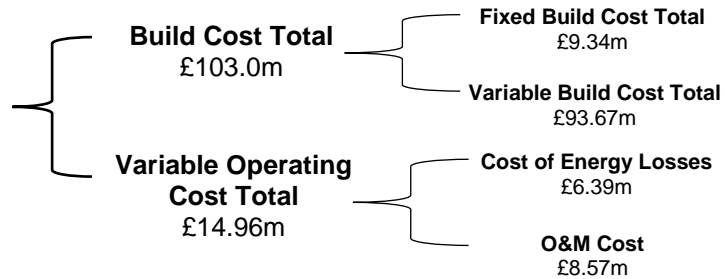

Lifetime Cost per km	£39.32m/km
Lifetime Power Transfer Cost per km	£5,255/MWkm

Data Source: TO and supply chain data

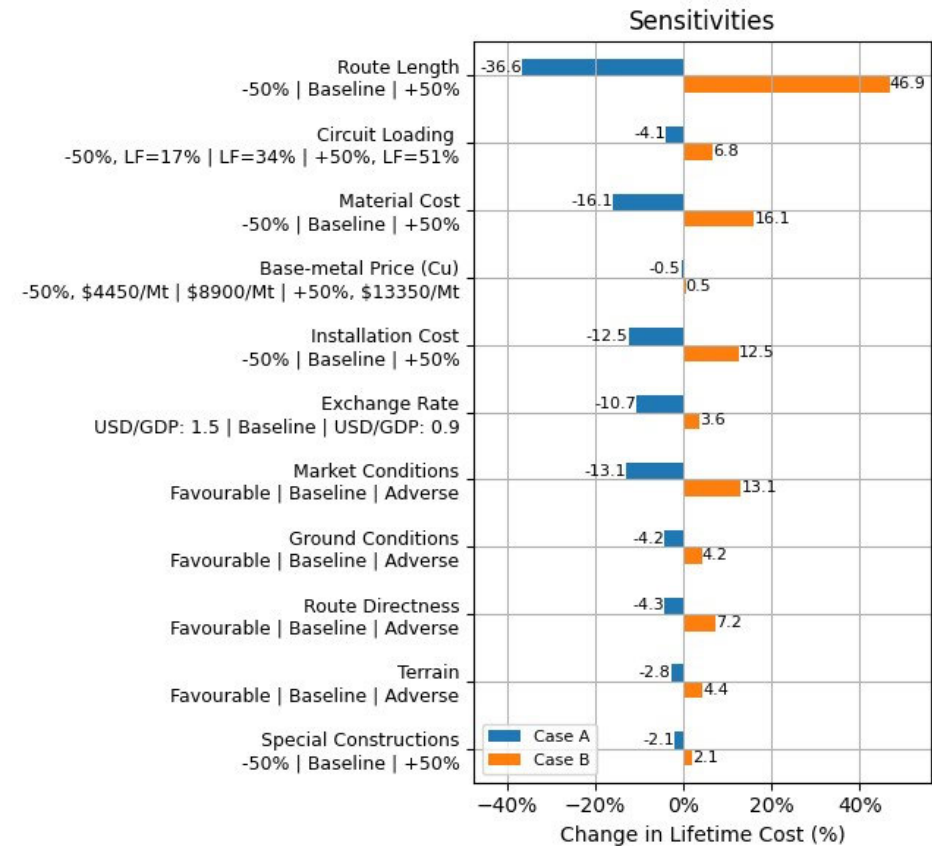
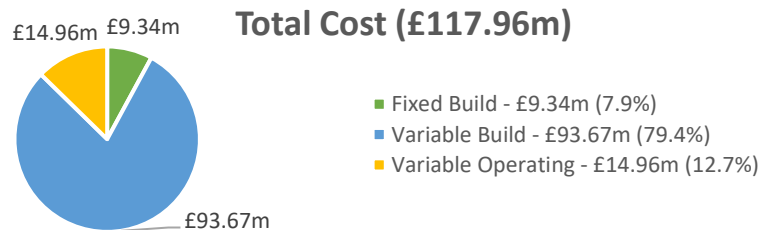
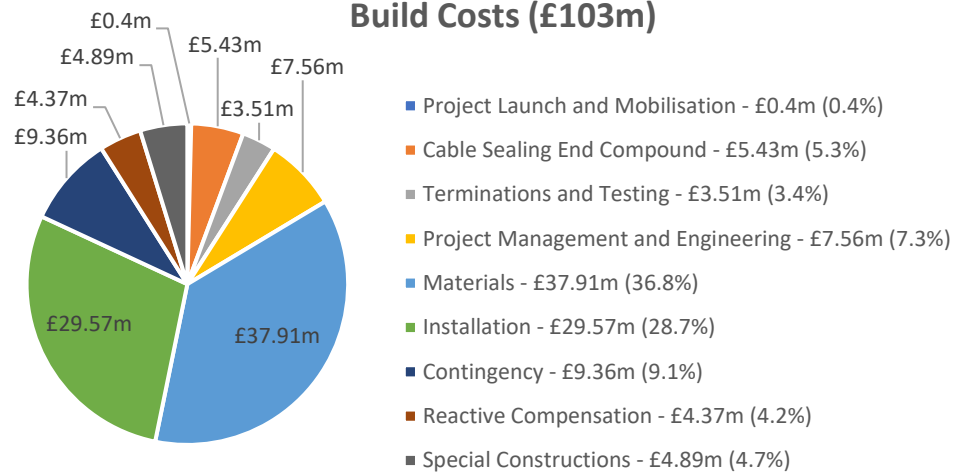

Underground Cable Buried – 15 km – Low Rating (2,494 MW)

Lifetime Cost
£222.72m

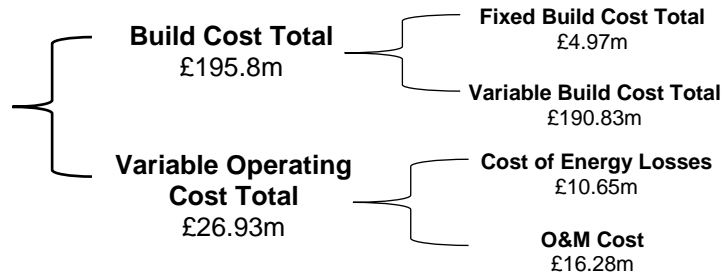

Lifetime Cost per km	£14.85m/km
Lifetime Power Transfer Cost per km	£5,953/MWkm

Data Source: TO and supply chain data

Build Costs (£195.8m)

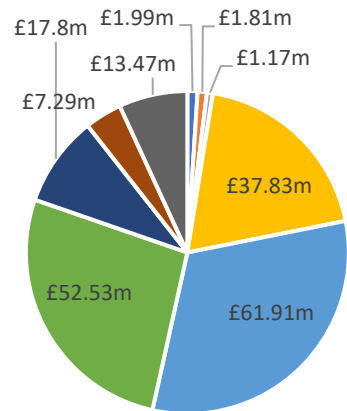

- Project Launch and Mobilisation - £1.99m (1%)
- Cable Sealing End Compound - £1.81m (0.9%)
- Terminations and Testing - £1.17m (0.6%)
- Project Management and Engineering - £37.83m (19.3%)
- Materials - £61.91m (31.6%)
- Installation - £52.53m (26.8%)
- Contingency - £17.8m (9.1%)
- Reactive Compensation - £7.29m (3.7%)
- Special Constructions - £13.47m (6.9%)

Total Cost (£222.73m)

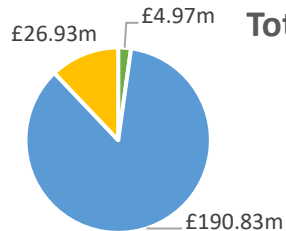

- Fixed Build - £4.97m (2.2%)
- Variable Build - £190.83m (85.7%)
- Variable Operating - £26.93m (12.1%)

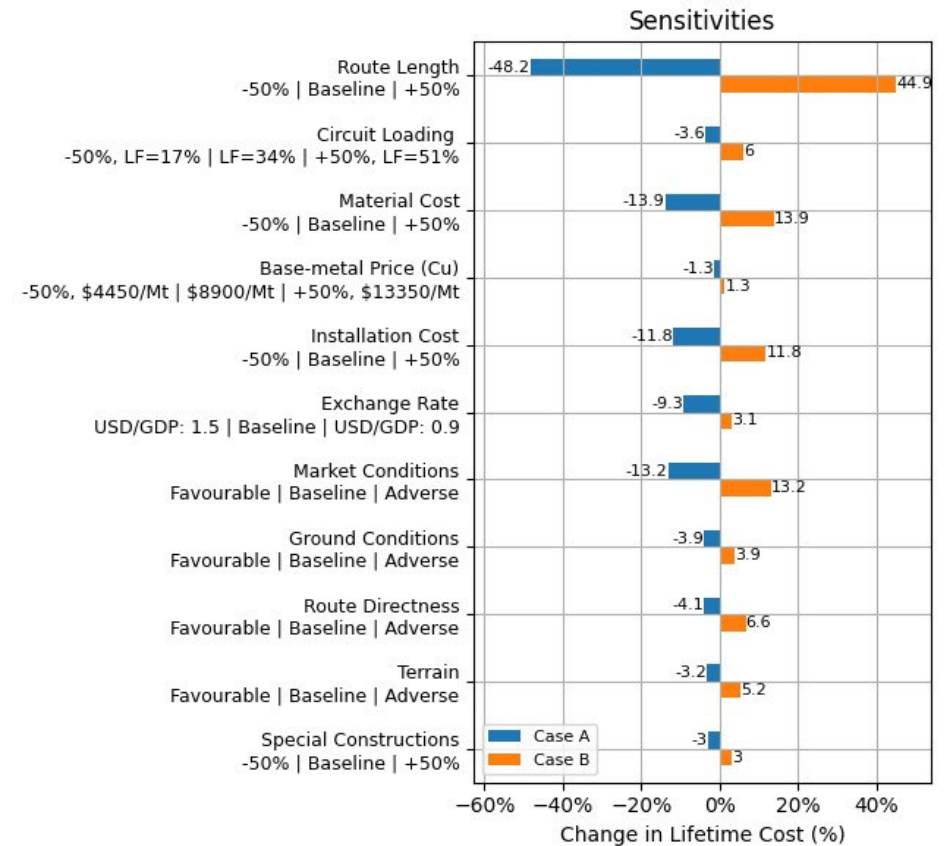

Underground Cable Buried – 15 km – Medium Rating (4,988 MW)

Lifetime Cost
£374.96m

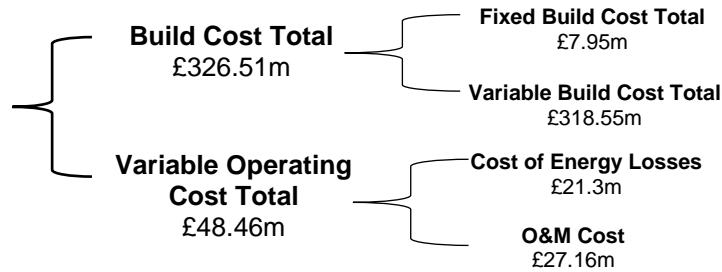

Lifetime Cost per km	£25.00m/km
Lifetime Power Transfer Cost per km	£5,012/MWkm

Data Source: TO and supply chain data

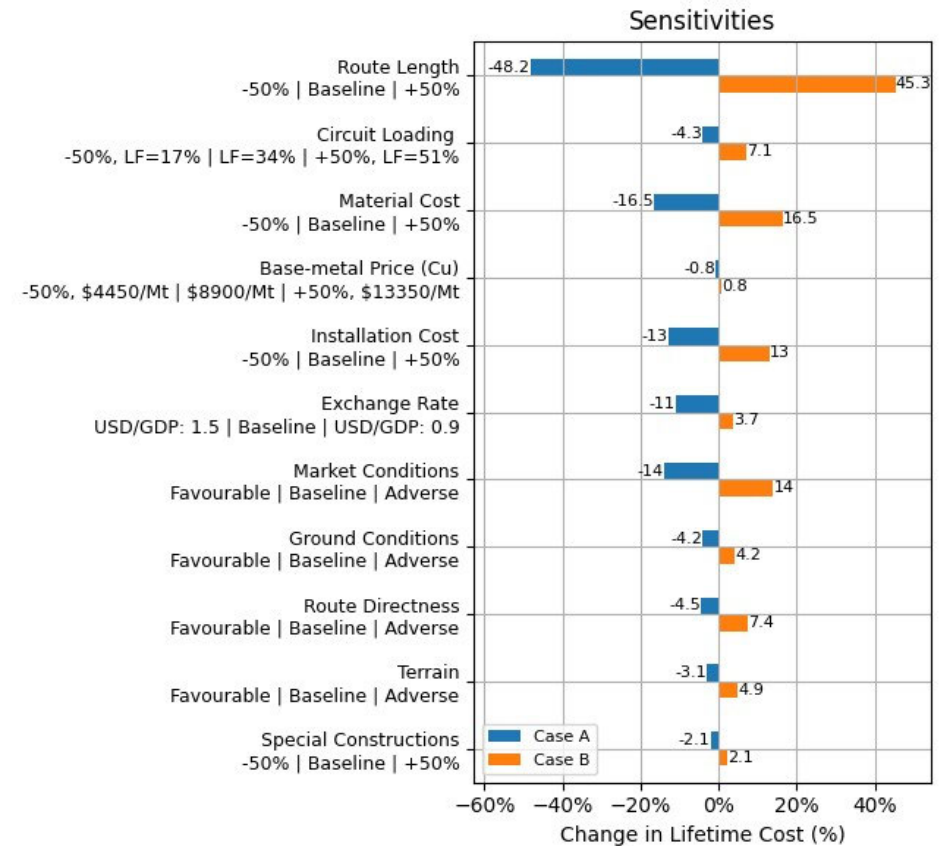
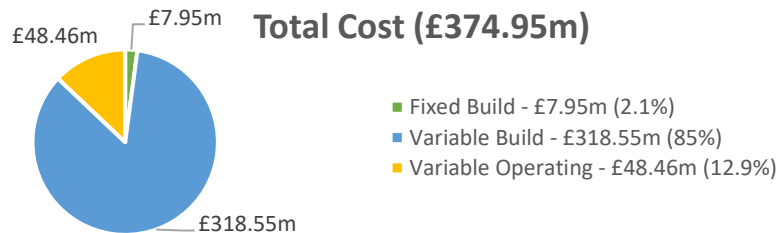
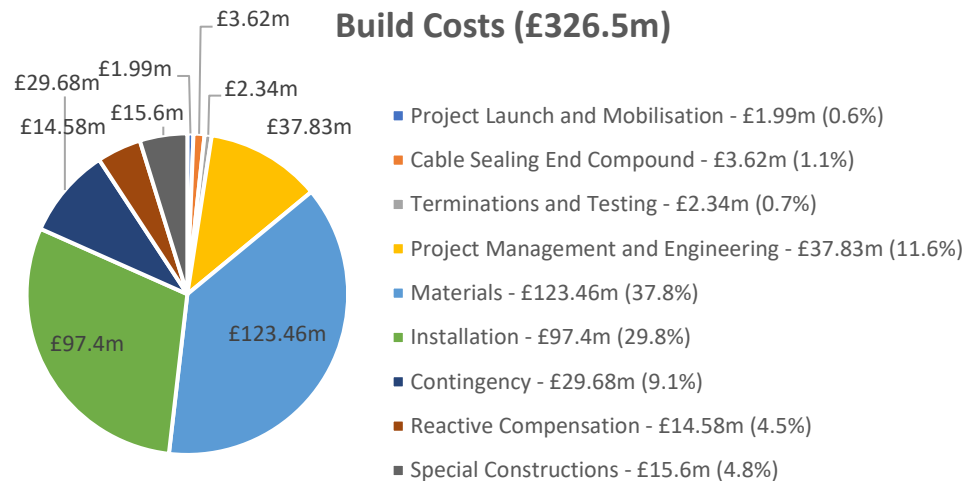

Underground Cable Buried – 15 km – High Rating (7,482 MW)

Lifetime Cost
£525.13m

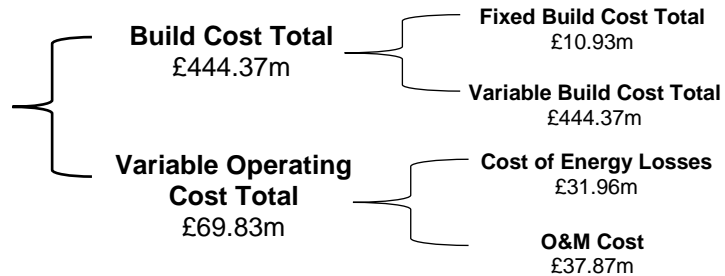

Lifetime Cost per km	£35.01m/km
Lifetime Power Transfer Cost per km	£4,679/MWkm

Data Source: TO and supply chain data

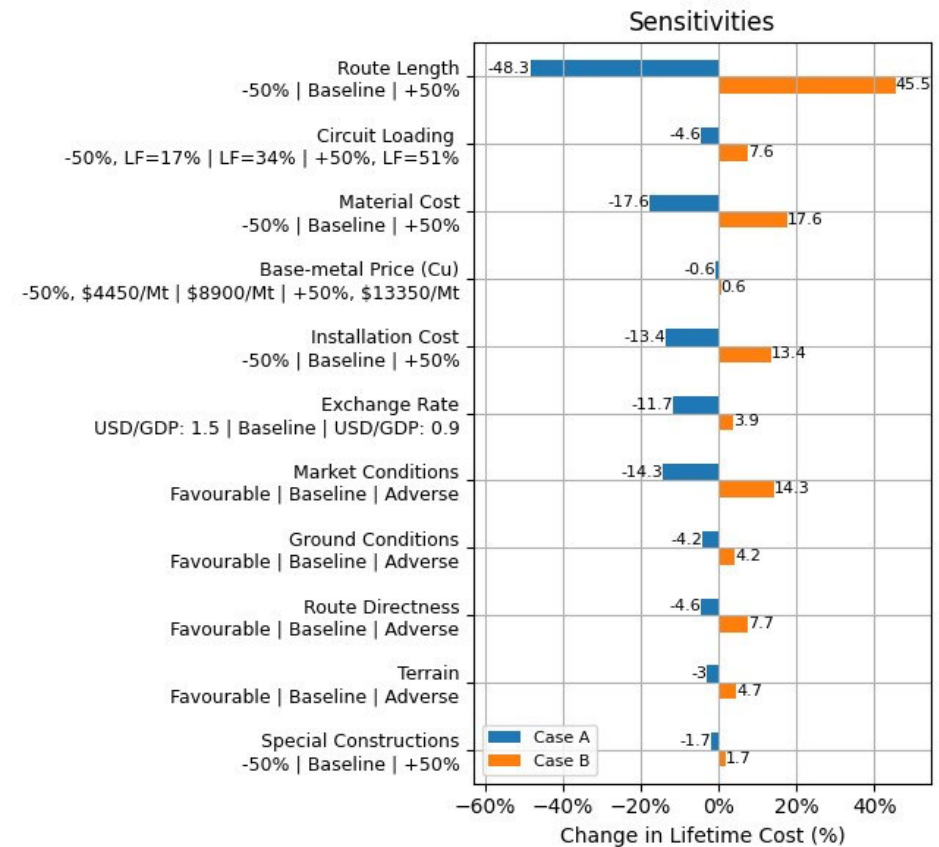
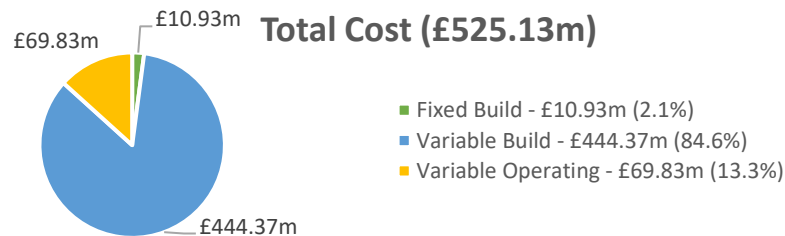
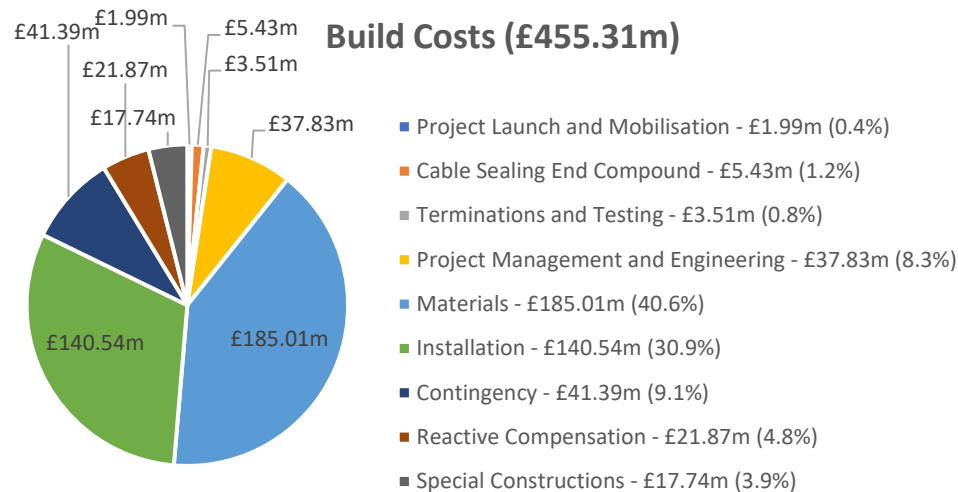

Underground Cable Buried – 75 km – Low Rating (2,494 MW)

Lifetime Cost
£1,047.75m

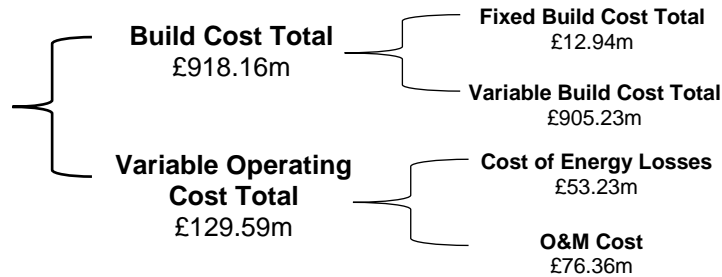

Lifetime Cost per km	£13.97m/km
Lifetime Power Transfer Cost per km	£5,601/MWkm

Data Source: TO and supply chain data

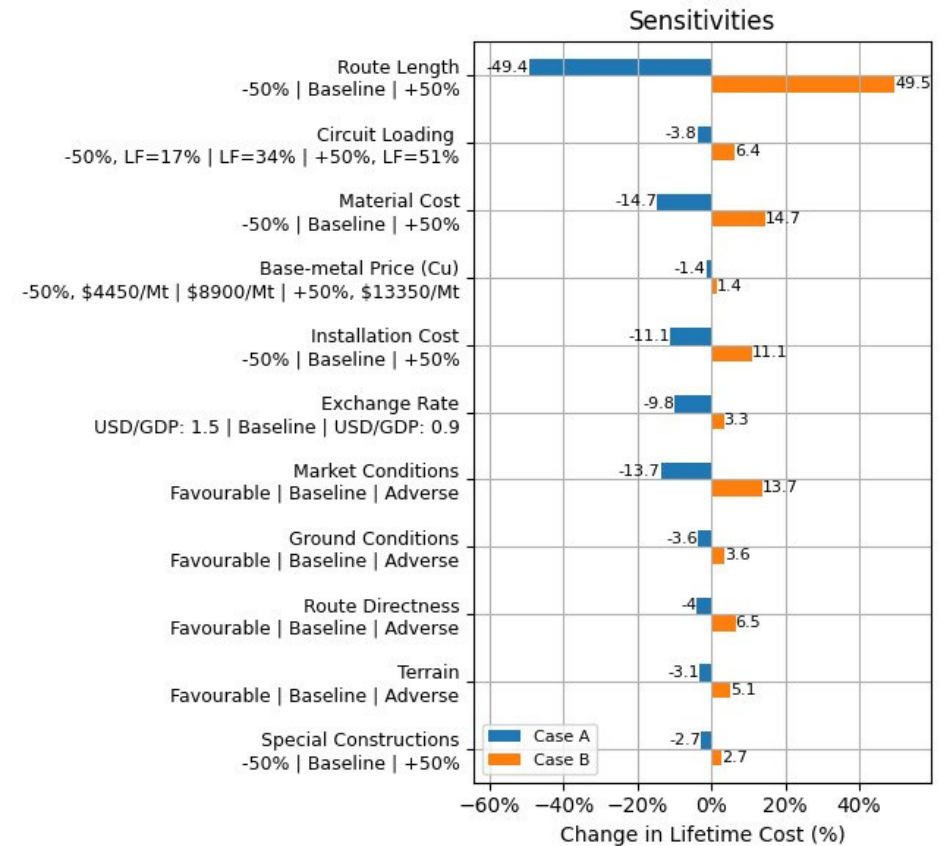
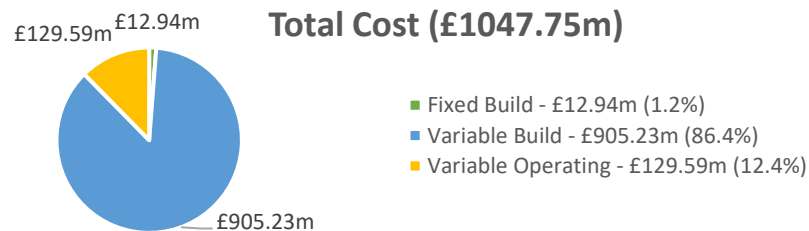
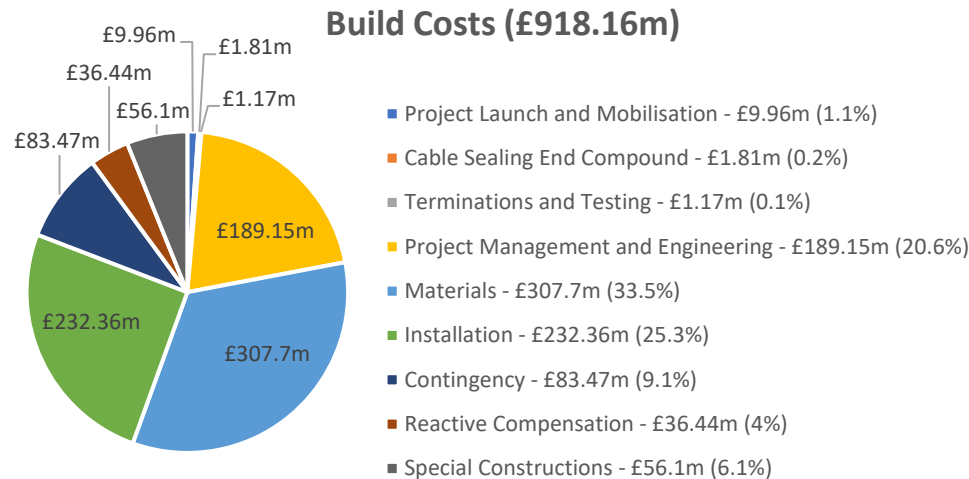

Underground Cable Buried – 75 km – Med Rating (4,988 MW)

Lifetime Cost
£1,770.54m

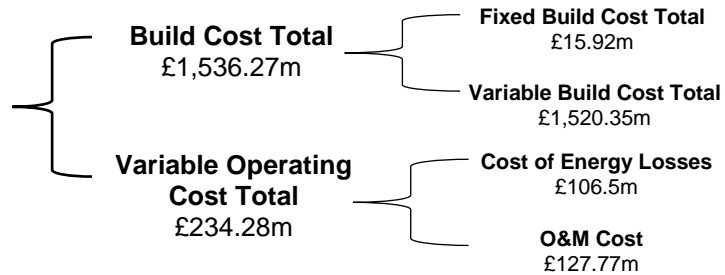

Lifetime Cost per km	£23.61m/km
Lifetime Power Transfer Cost per km	£4,733/MWkm

Data Source: TO and supply chain data

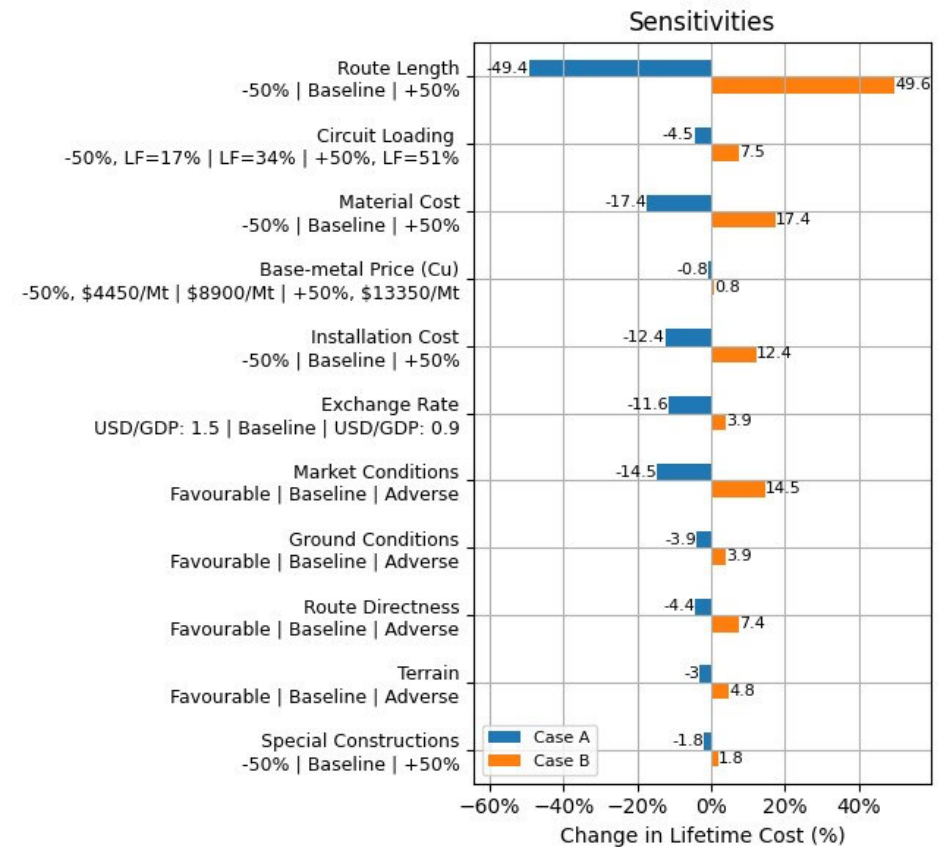
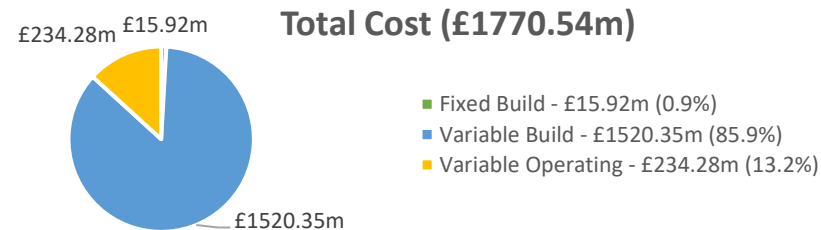
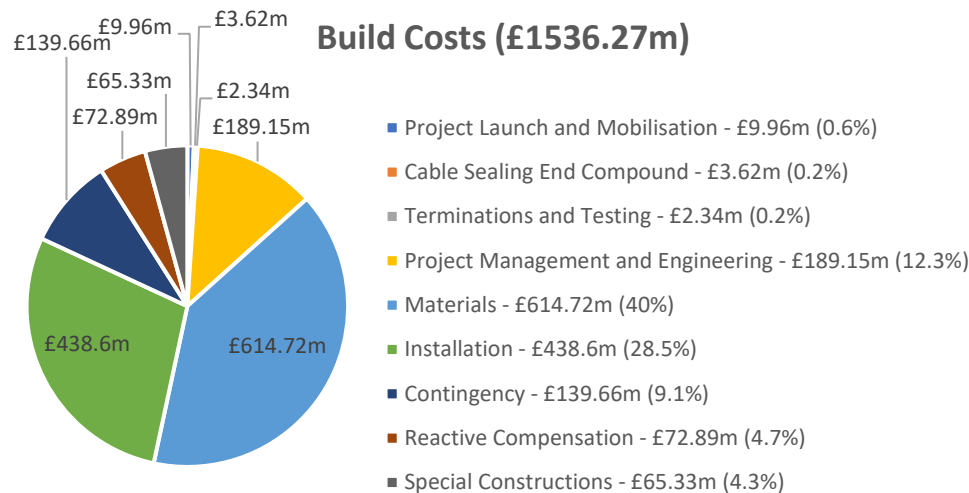

Underground Cable Buried – 75 km – High Rating (7,482 MW)

Lifetime Cost
£2,485.53m

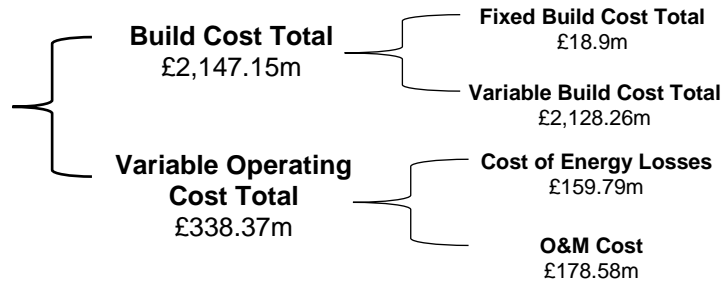

Lifetime Cost per km	£33.14m/km
Lifetime Power Transfer Cost per km	£4,429/MWkm

Data Source: TO and supply chain data

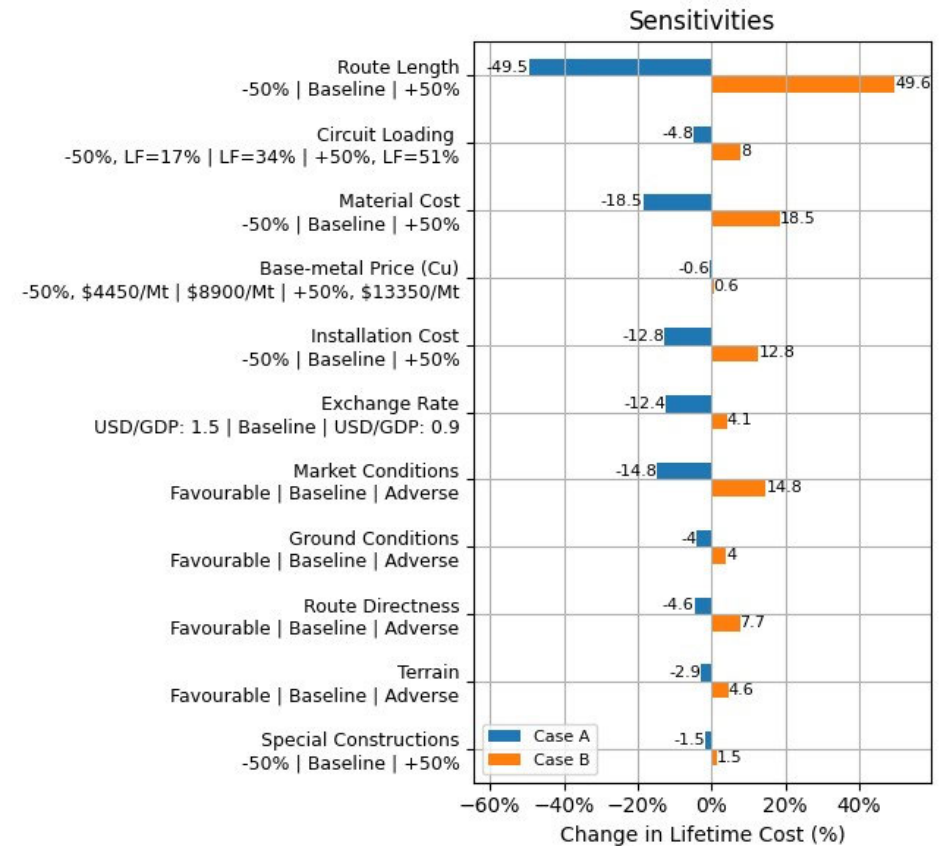
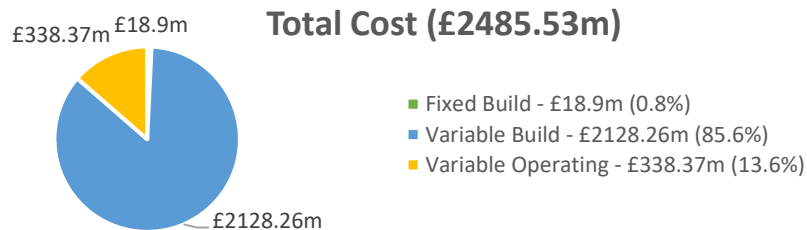
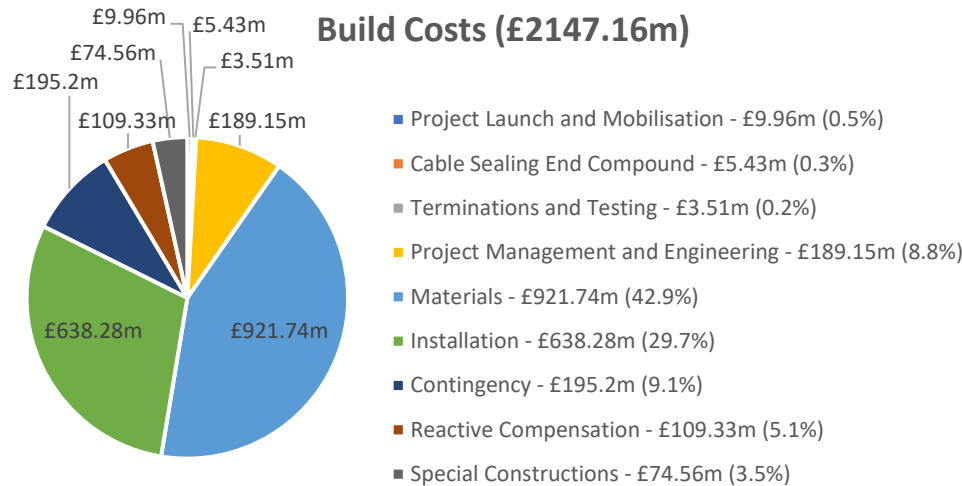

UGC Buried Lifetime Cost

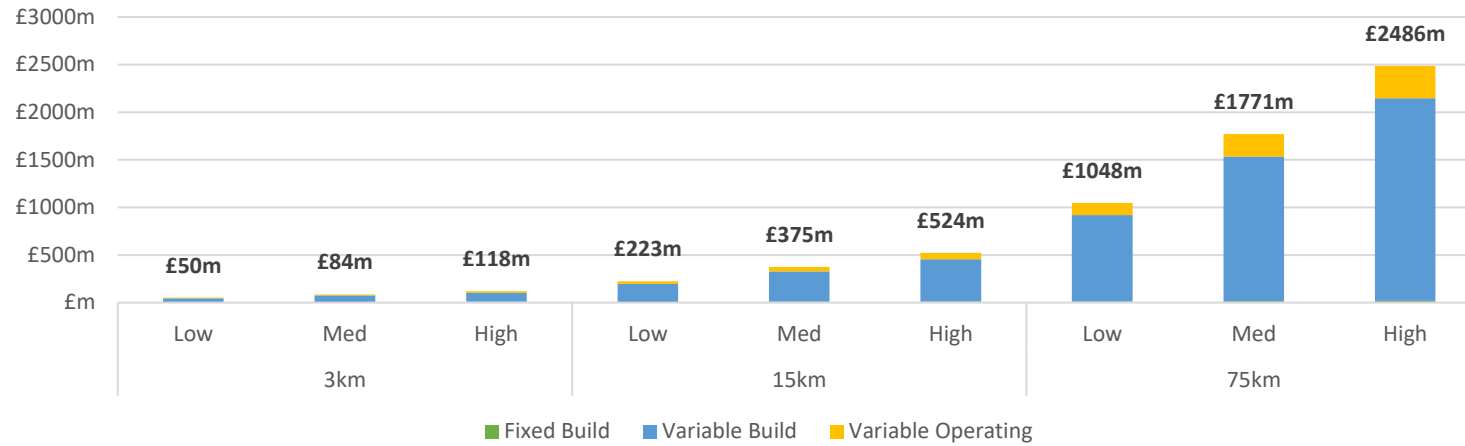

UGC Buried Lifetime Cost/km

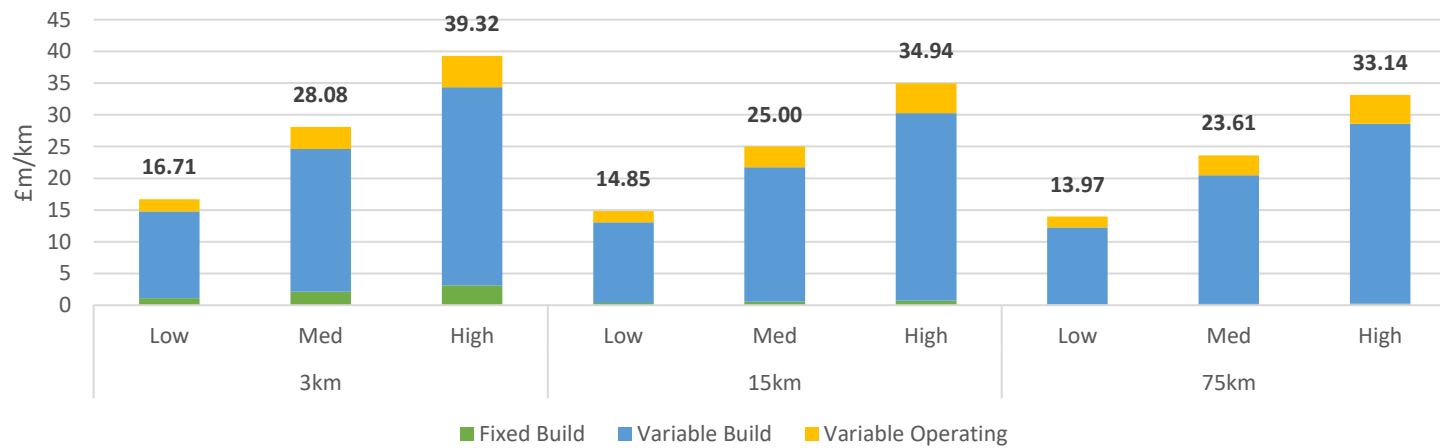

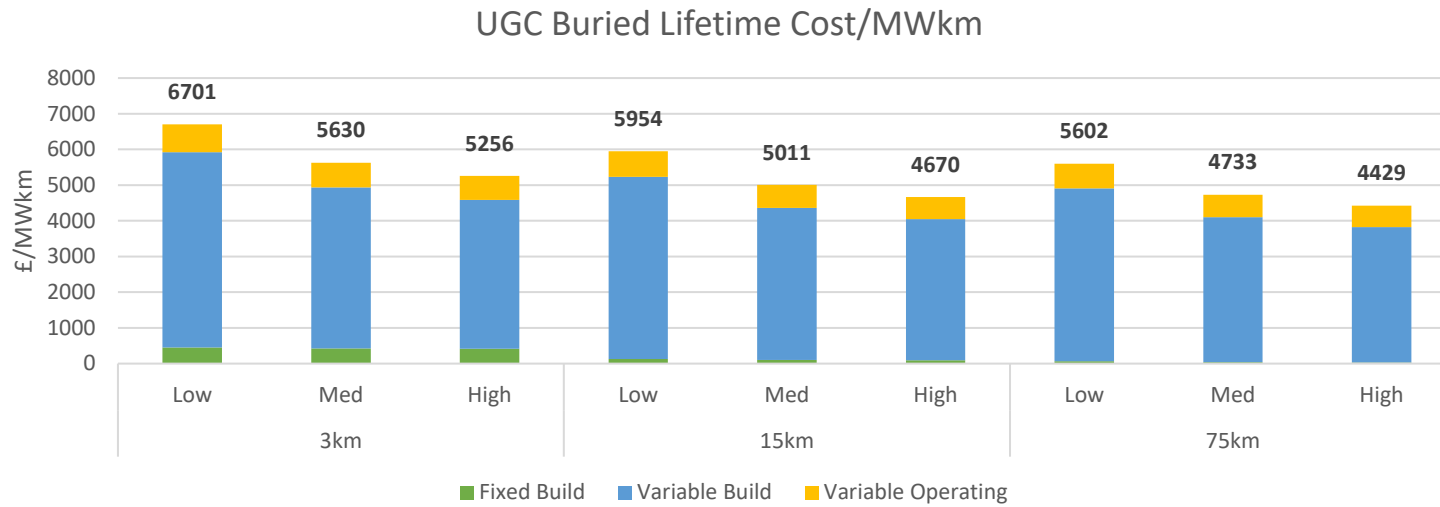

From the figures above we can see the medium rated construction is around 1.7 times the cost of the low, and the high rating is around 1.4 times the cost of the medium. However, in each rating increment we are increasing the power transfer by 2,494 MW, but also doubling the quantity of conductors, and thus the losses are even across a given route length. As there are construction efficiencies associated with both increasing the number of conductors, and also increasing the route length, the costs decrease when the route is longer but also when the power transfer is higher.

Underground Cable Tunnel – 3 km – Low Rating (2,494 MW)

Lifetime Cost
£184.49m

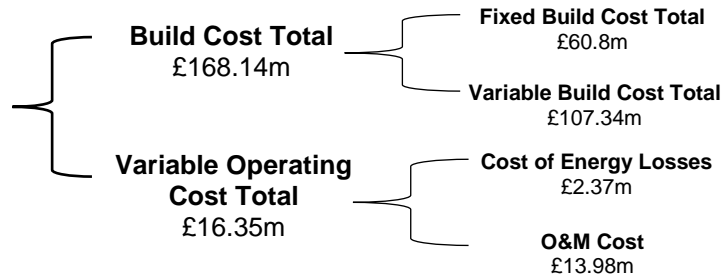

Lifetime Cost per km	£61.50m/km
Lifetime Power Transfer Cost per km	£24,658/MWkm

Data Source: TO and public domain data

Build Costs (£168.14m)

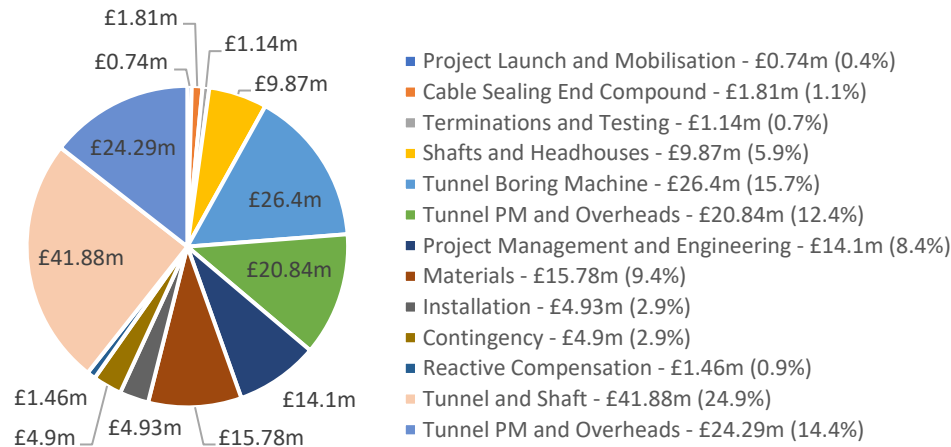

Total Cost (£184.49m)

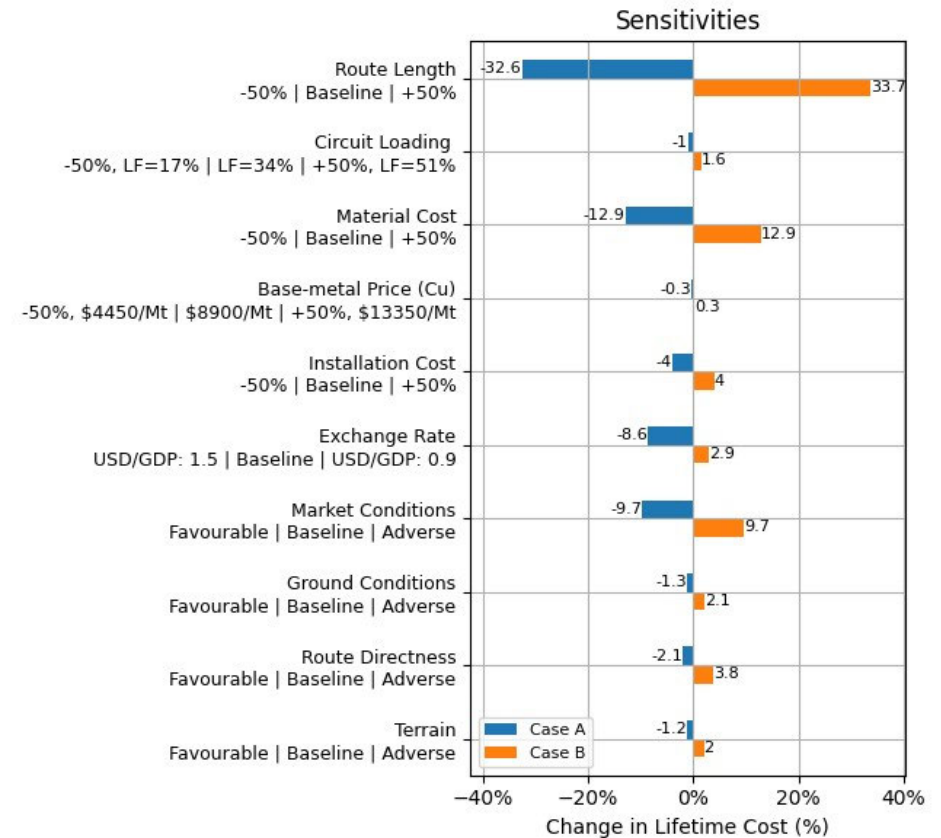
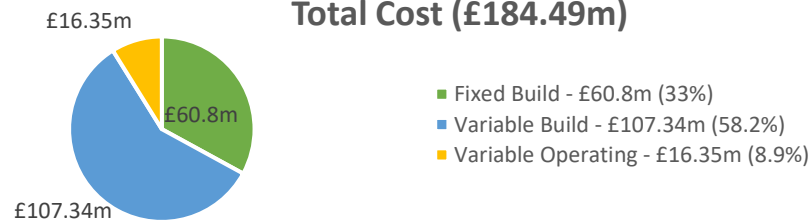

Underground Cable Tunnel – 3 km – Medium Rating (4,988 MW)

Lifetime Cost
£238.46m

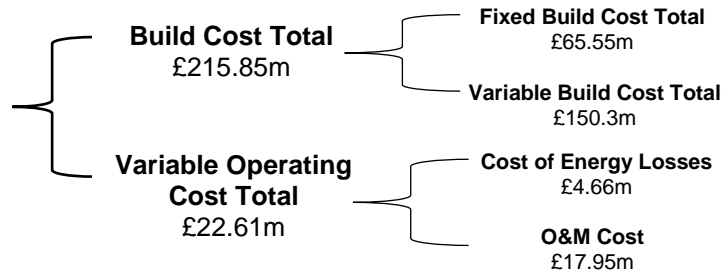

Lifetime Cost per km	£79.49m/km
Lifetime Power Transfer Cost per km	£15,936/MWkm

Data Source: TO and public domain data

Build Costs (£215.85m)

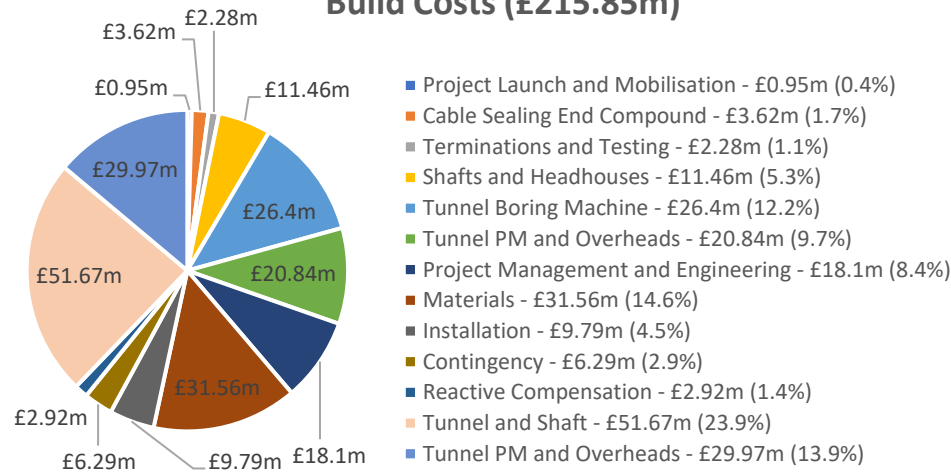

Total Cost (£238.46m)

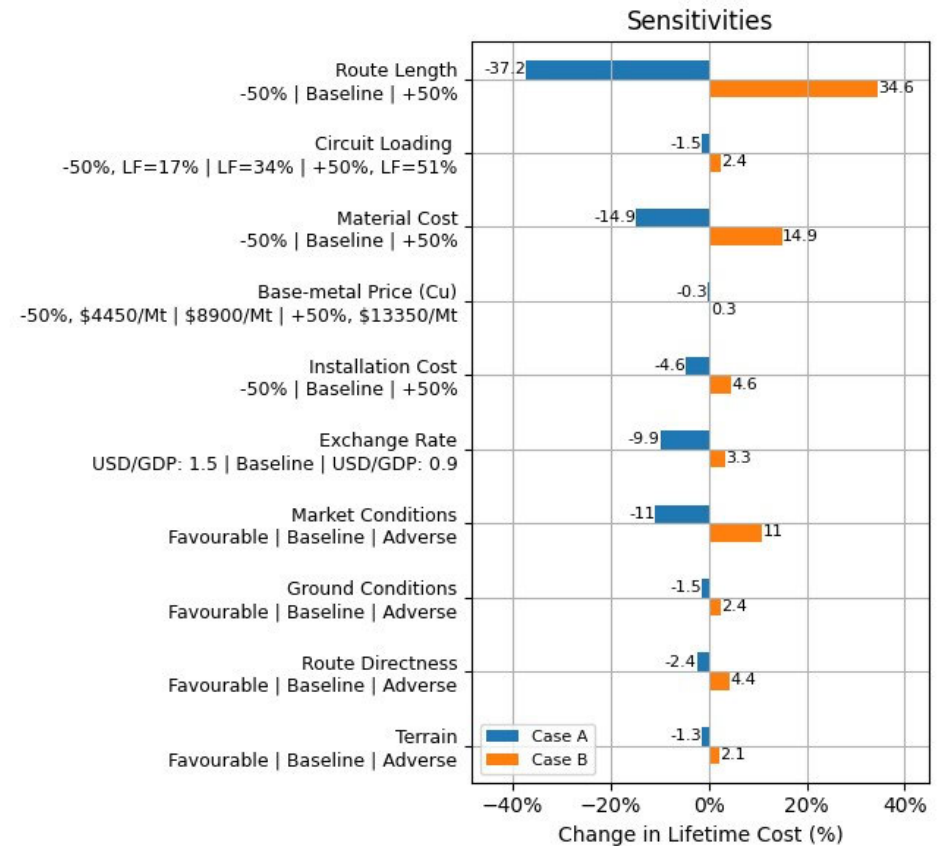
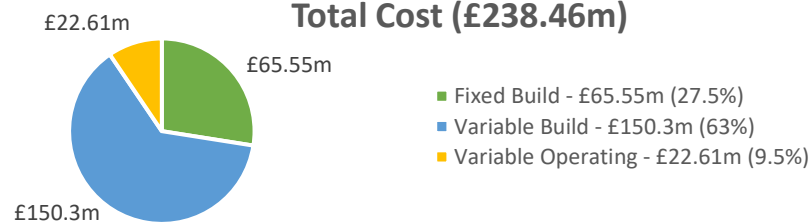

Underground Cable Tunnel – 3 km – High Rating (7,482 MW)

Lifetime Cost
£247.67m

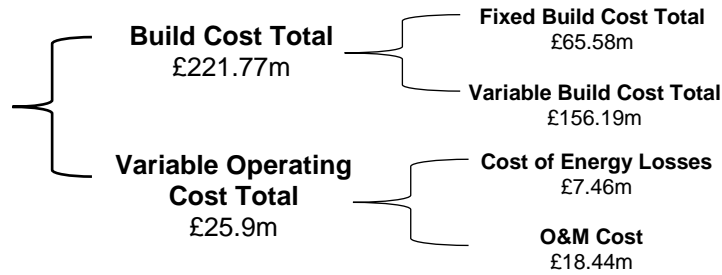

Lifetime Cost per km	82.56m/km
Lifetime Power Transfer Cost per km	£11,034/MWkm

Data Source: TO and public domain data

Note: Two conductors per phase as per medium rating

Build Costs (£221.77m)

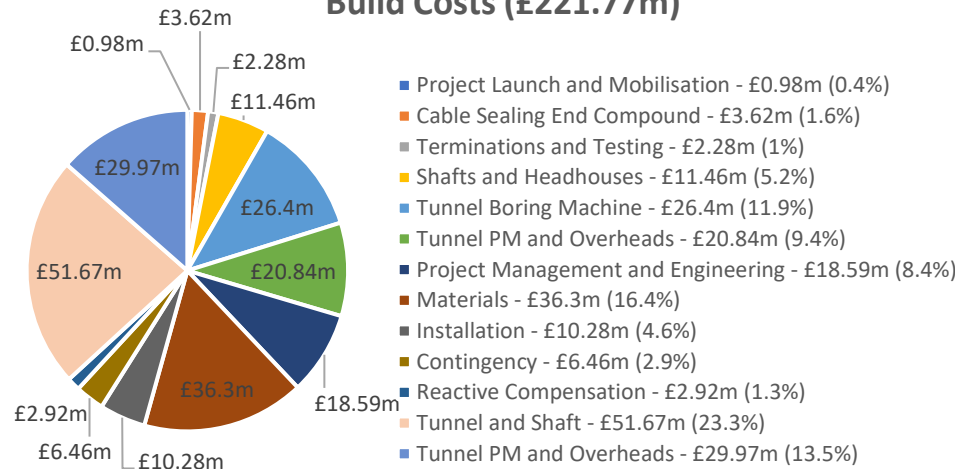

Total Cost (£247.67m)

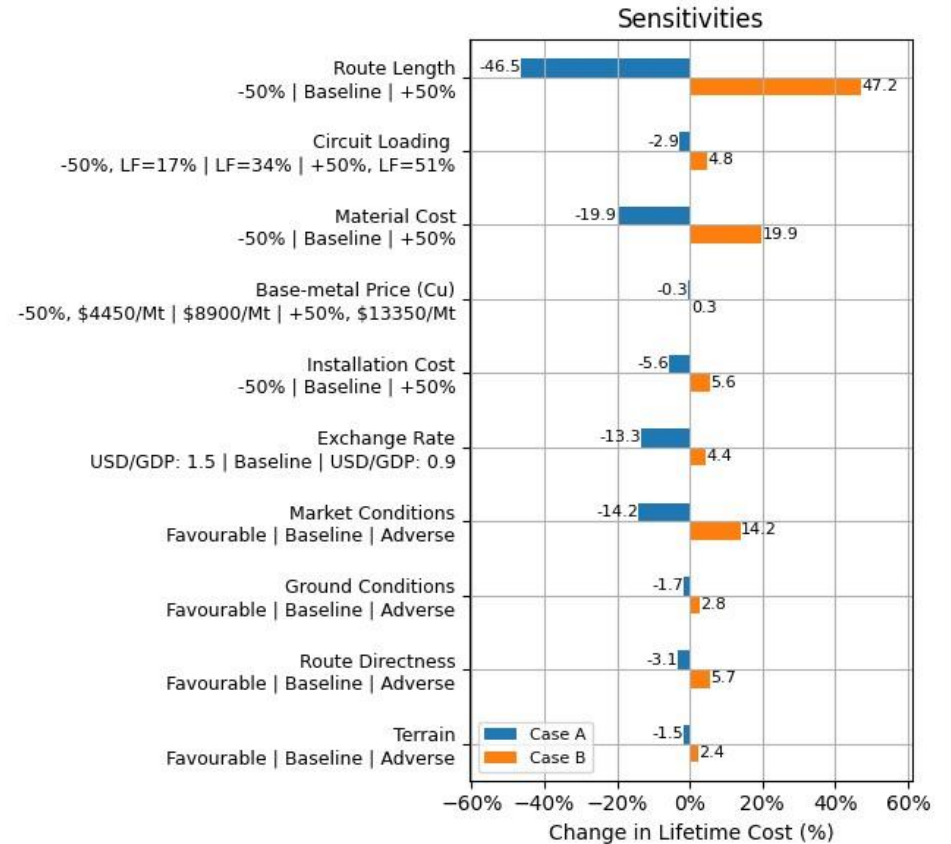
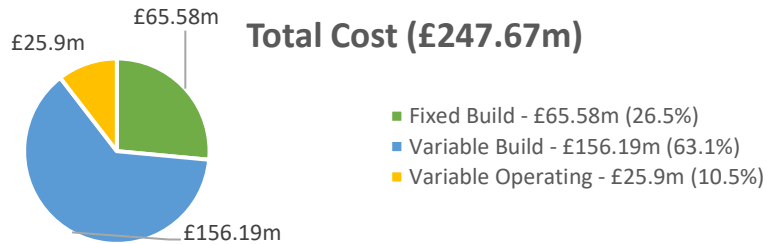

Underground Cable Tunnel – 15 km – Low Rating (2,494 MW)

Lifetime Cost
£675.58m

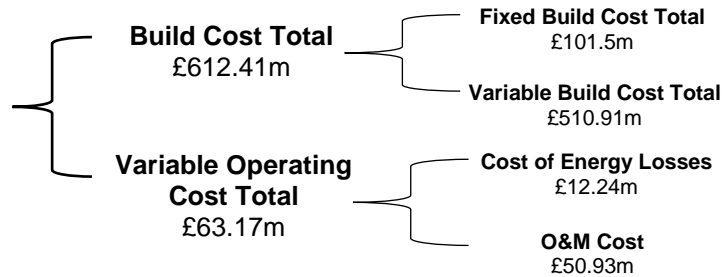

Lifetime Cost per km	£45.04m/km
Lifetime Power Transfer Cost per km	£18,059/MWkm

Data Source: TO and public domain data

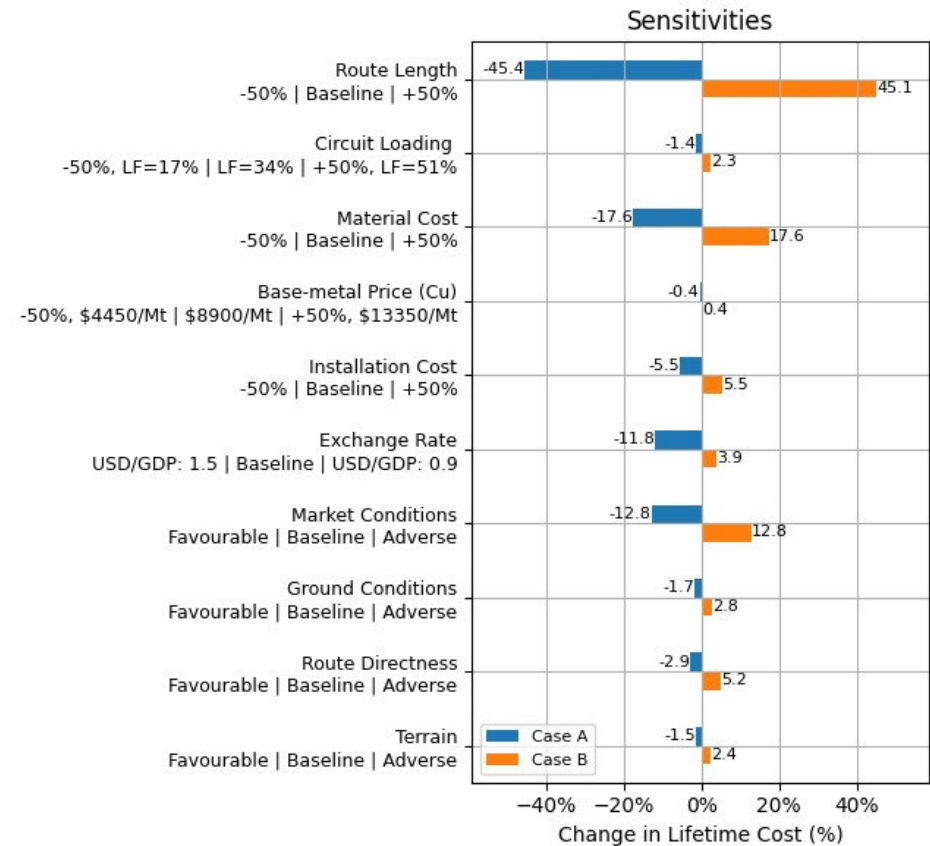
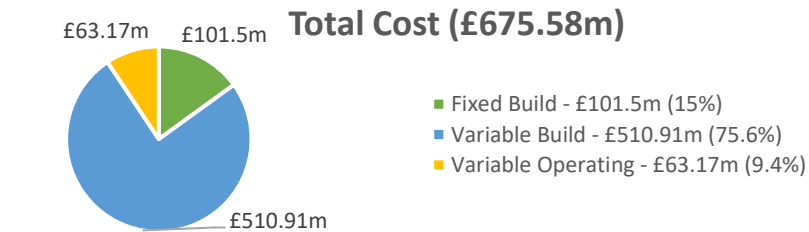
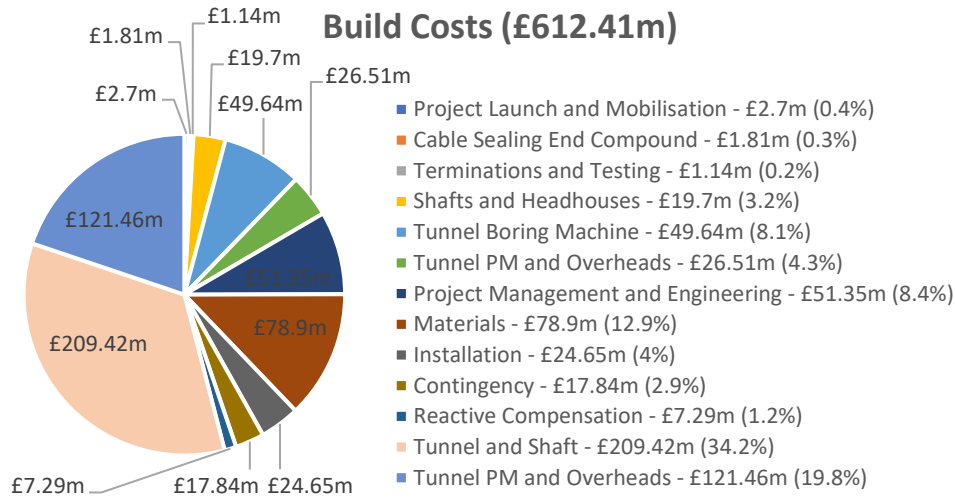

Underground Cable Tunnel – 15 km – Medium Rating (4,988 MW)

Lifetime Cost
£916.4m

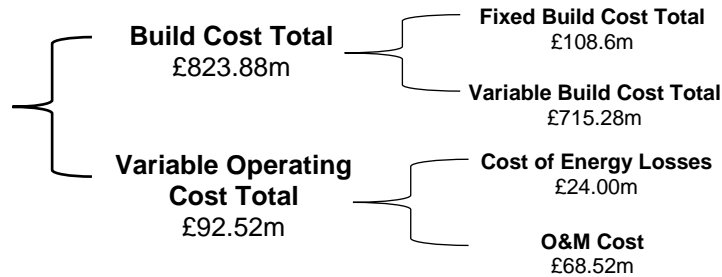

Lifetime Cost per km	£61.09m/km
Lifetime Power Transfer Cost per km	£12,248/MWkm

Data Source: TO and public domain data

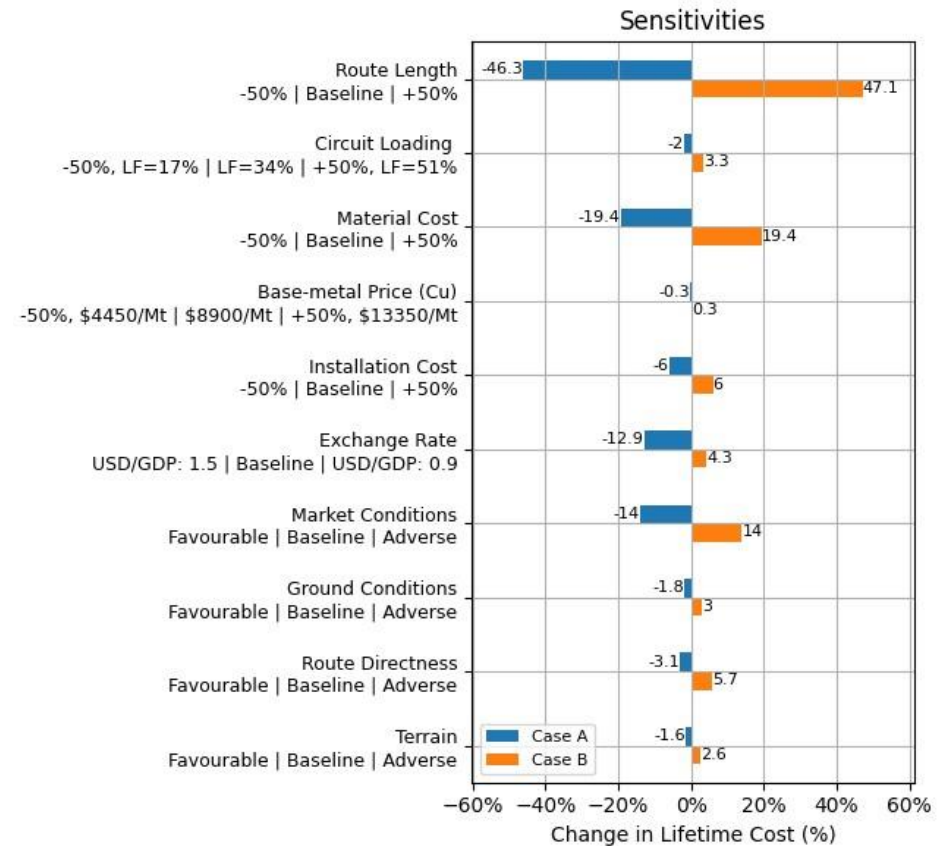
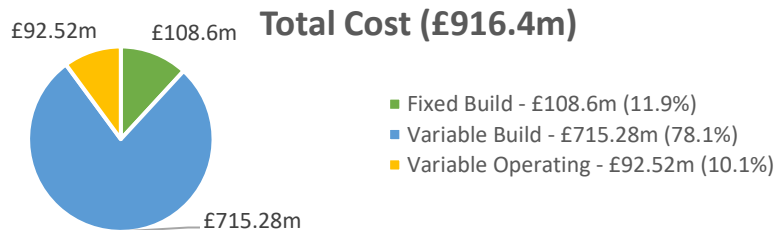
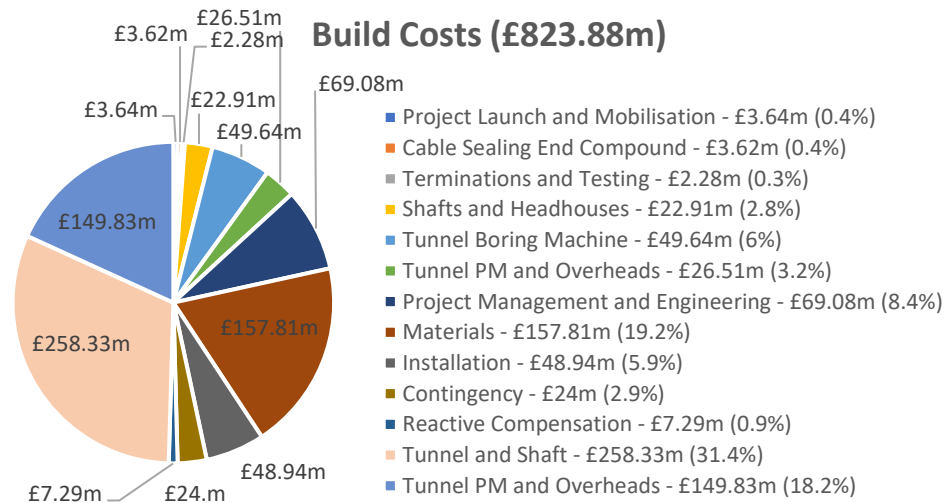

Underground Cable Tunnel – 15 km – High Rating (7,482 MW)

Lifetime Cost
£961.75m

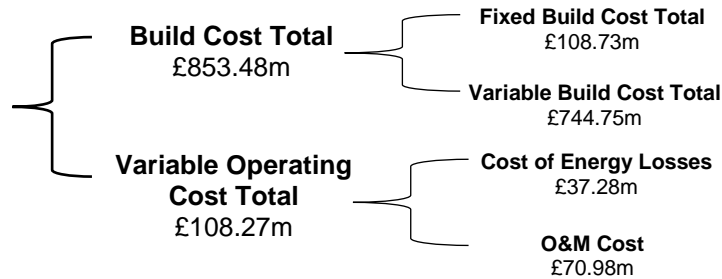

Lifetime Cost per km	£64.12m/km
Lifetime Power Transfer Cost per km	£8,569/MWkm

Data Source: [TO](#) and public domain data

Note: Two conductors per phase as per medium rating

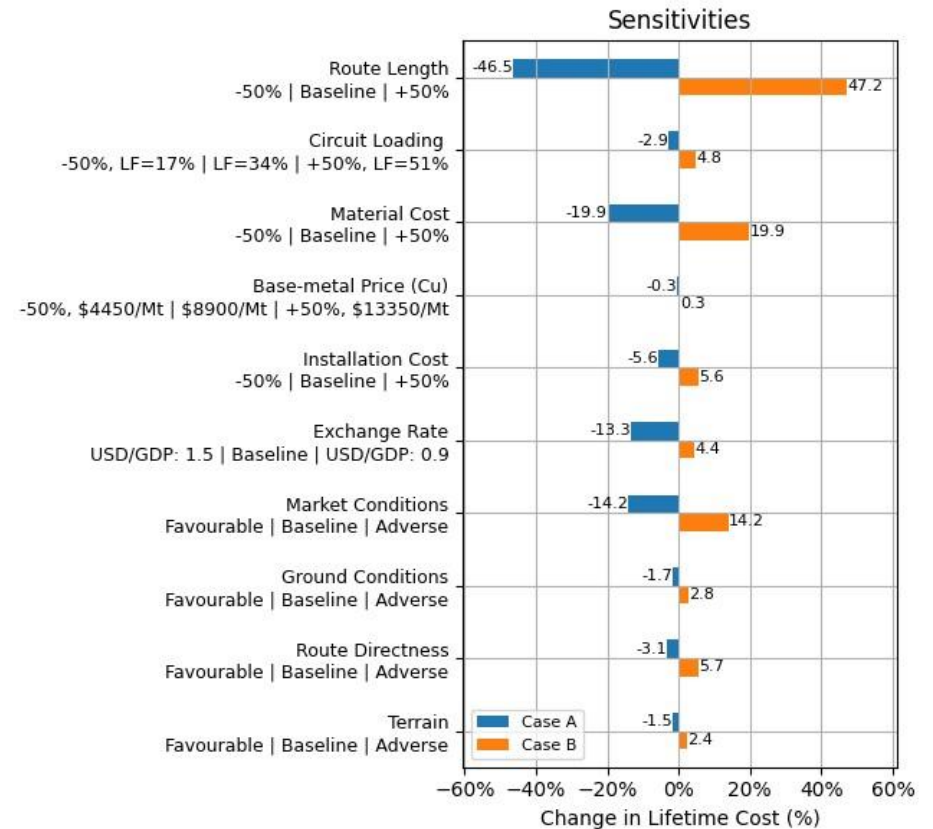
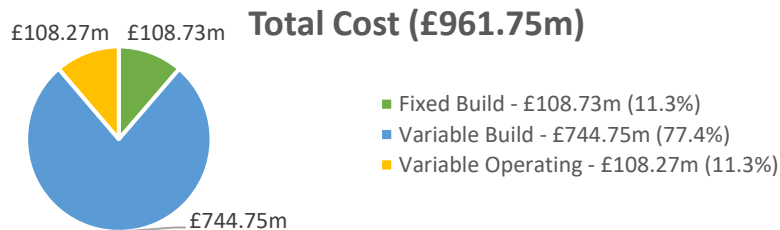
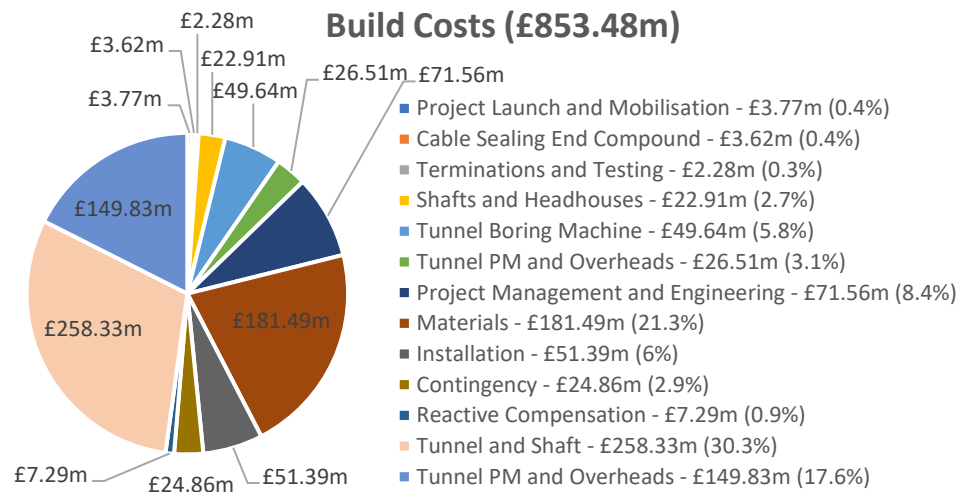

Underground Cable Tunnel – 75 km – Low Rating (2,494 MW)

Lifetime Cost
£3118.93m

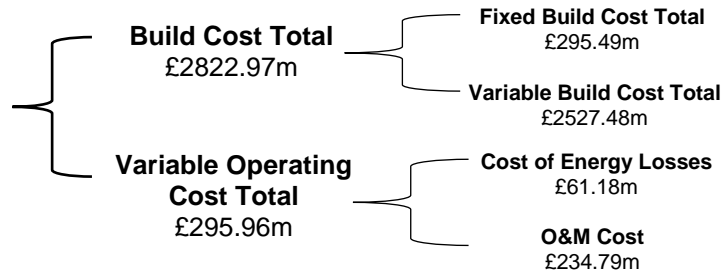

Lifetime Cost per km	£41.59m/km
Lifetime Power Transfer Cost per km	£16,674/MWkm

Data Source: TO and public domain data

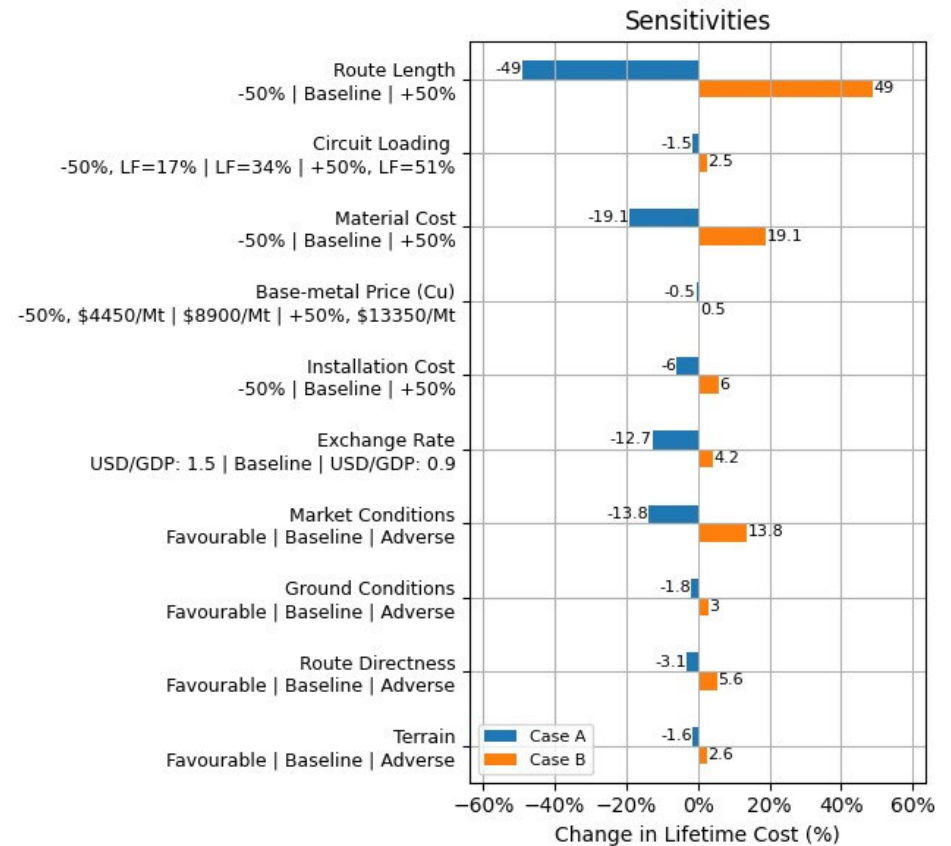
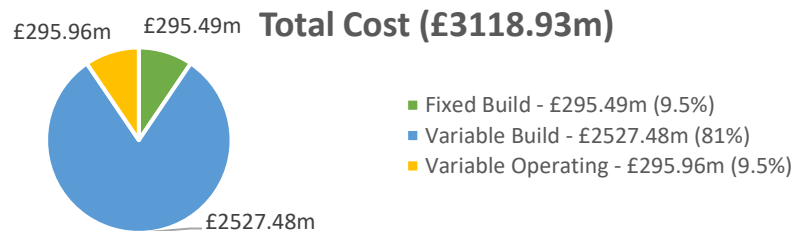
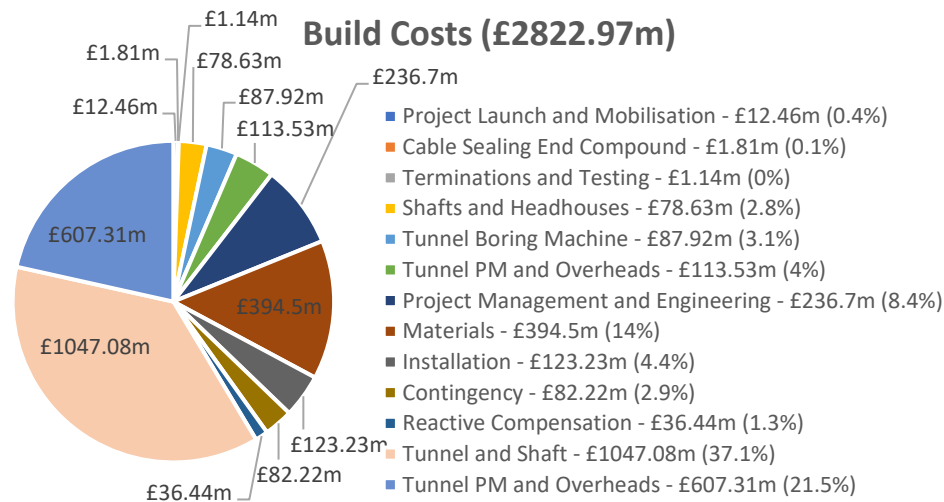

Underground Cable Tunnel – 75 km – Med Rating (4,988 MW)

Lifetime Cost
£4,343.89m

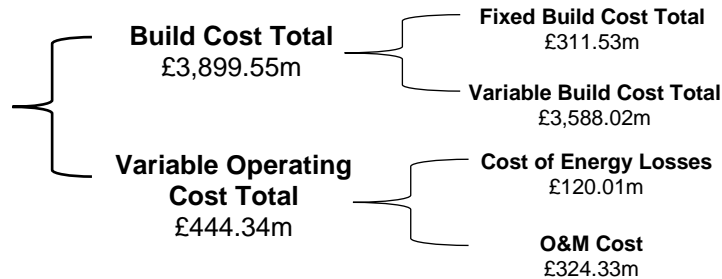

Lifetime Cost per km	£57.92m/km
Lifetime Power Transfer Cost per km	£11,612/MWkm

Data Source: TO and public domain data

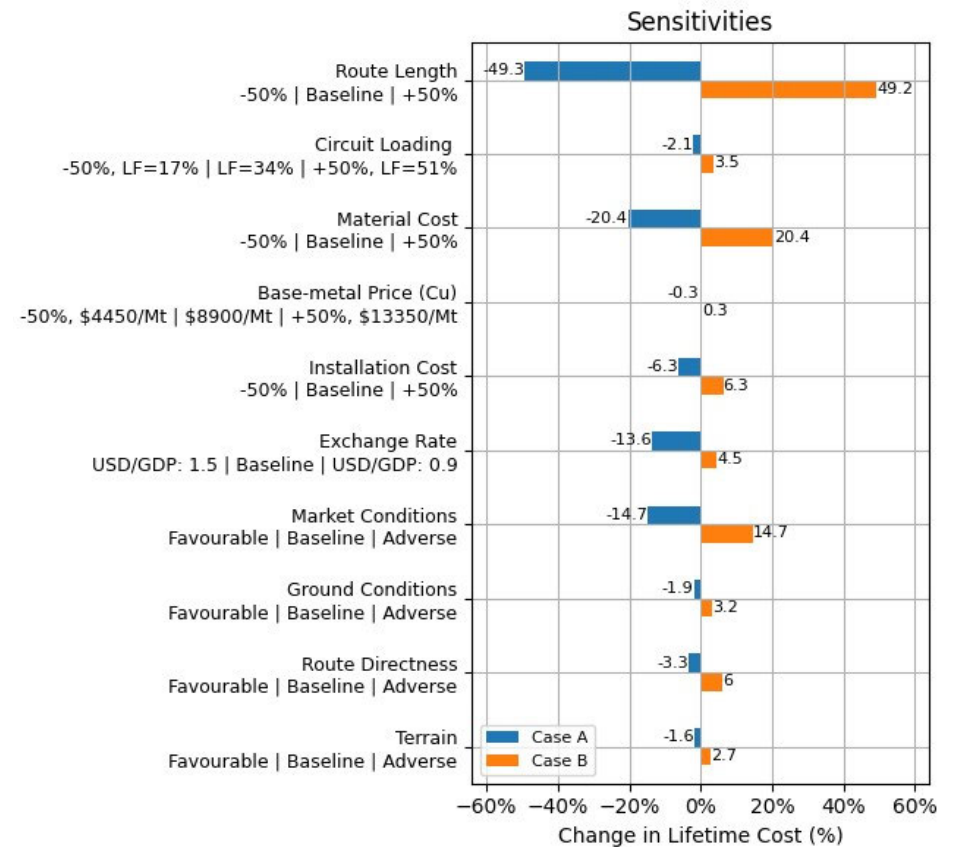
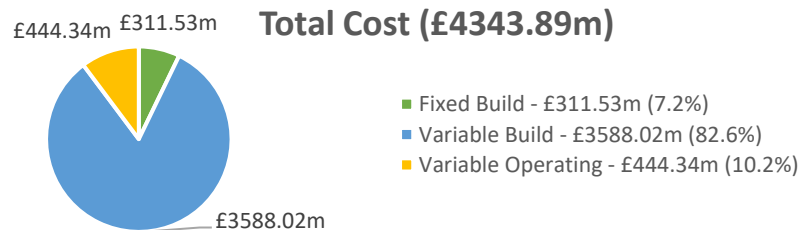
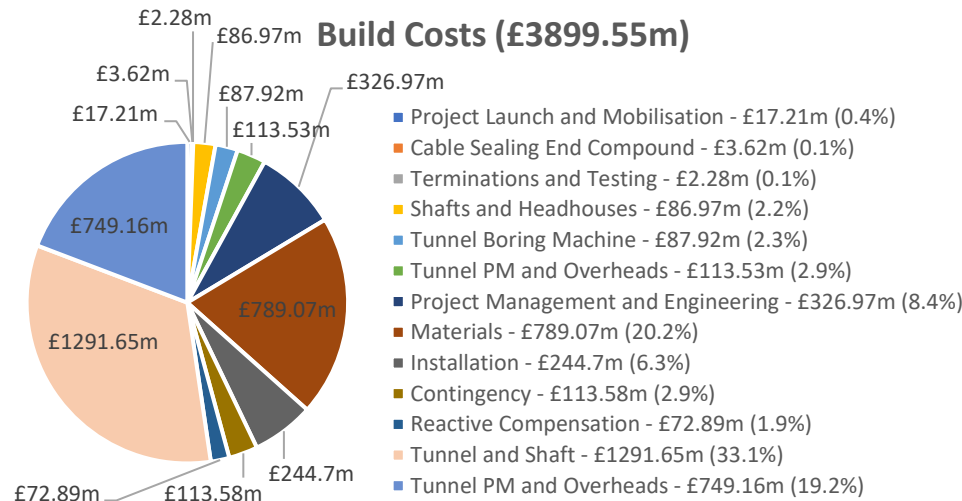

Underground Cable Tunnel – 75 km – High Rating (7,482 MW)

Lifetime Cost
£4,570.56m

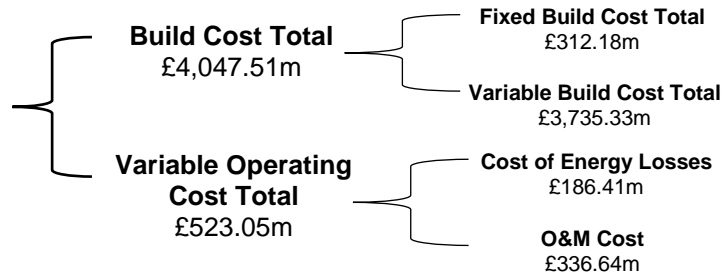

Lifetime Cost per km	£60.94m/km
Lifetime Power Transfer Cost per km	£8,145/MWkm

Data Source: TO and public domain data

Note: Two conductors per phase as per medium rating

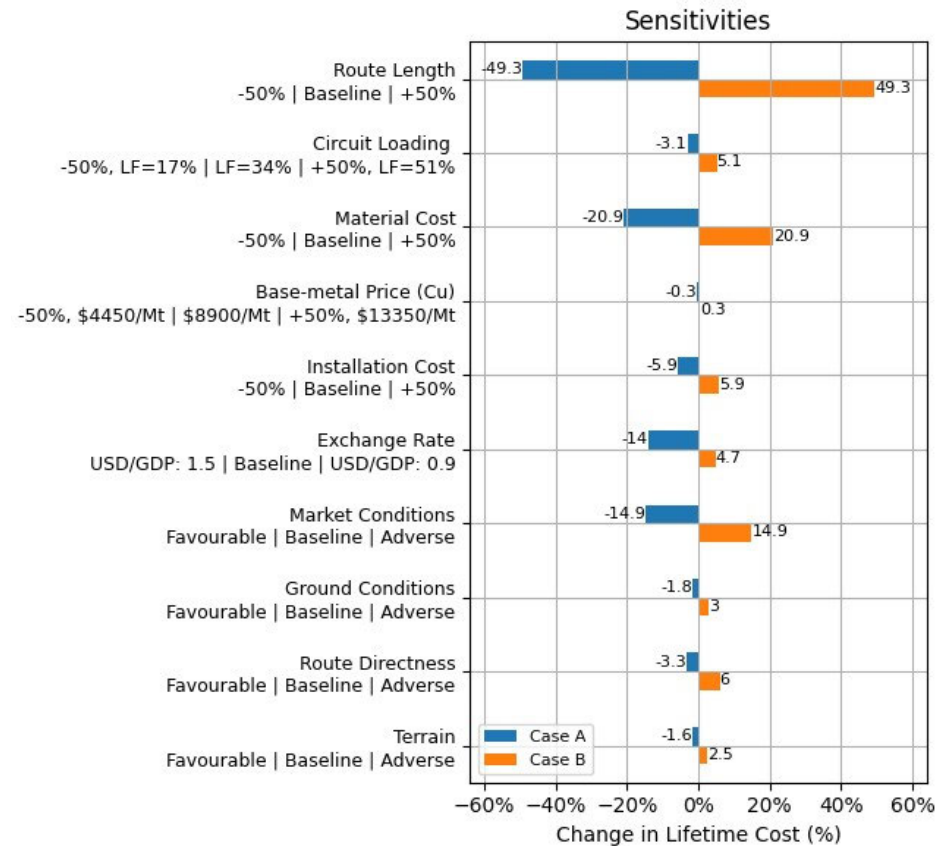
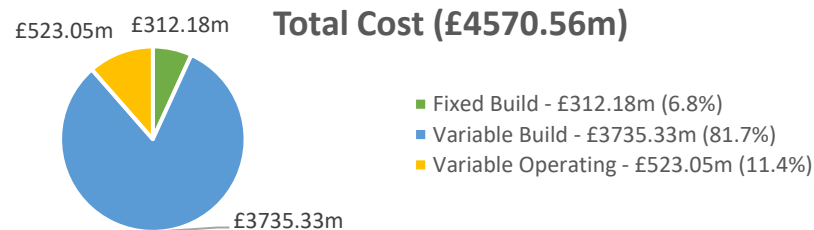
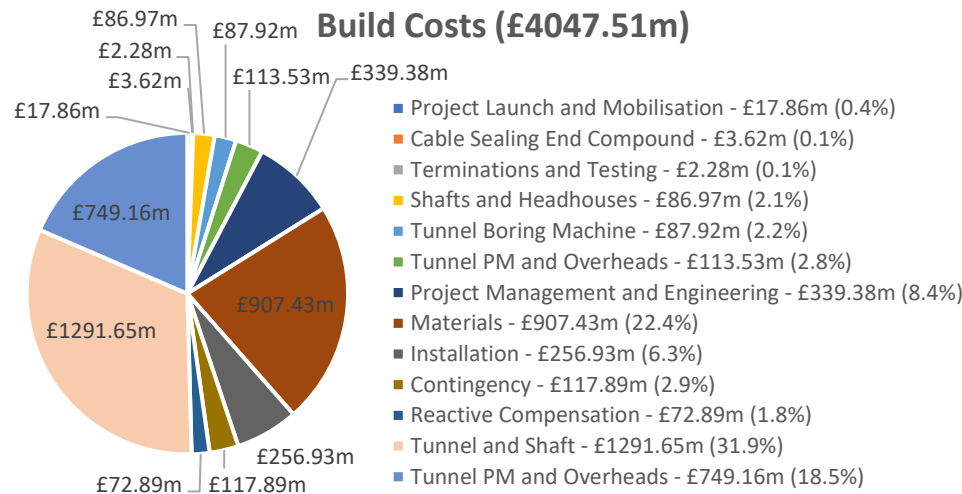

UGC Tunneled Lifetime Cost

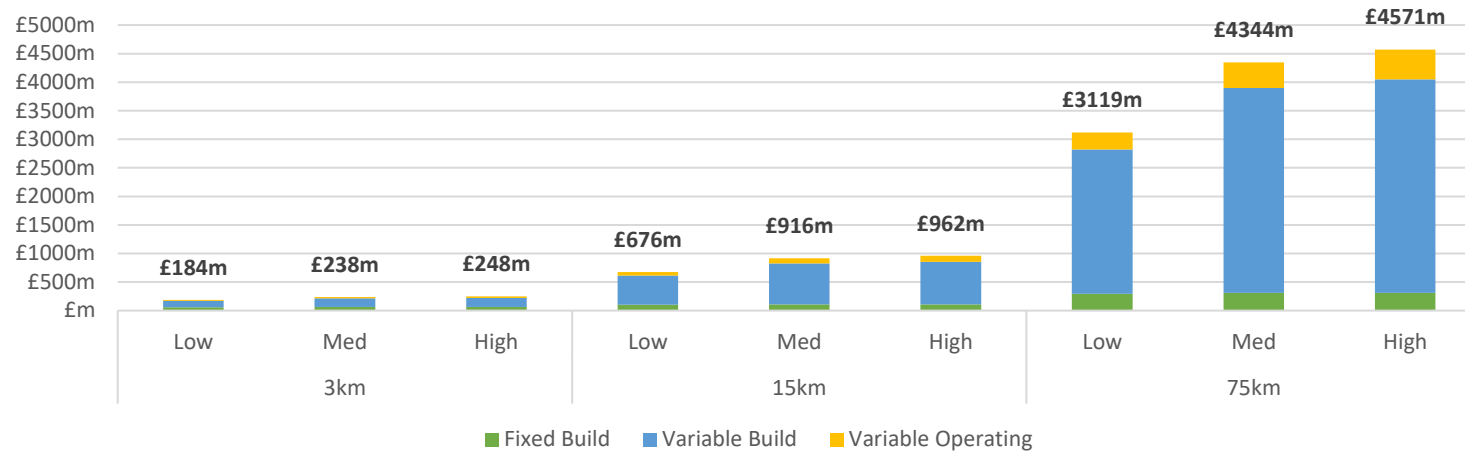

UGC Tunneled Lifetime Cost/km

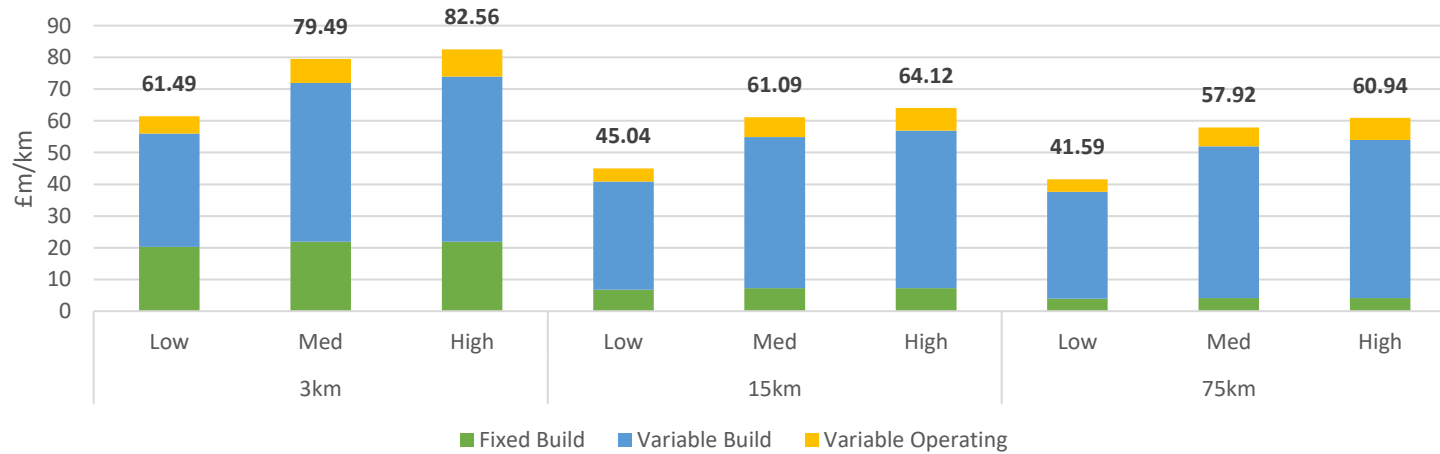

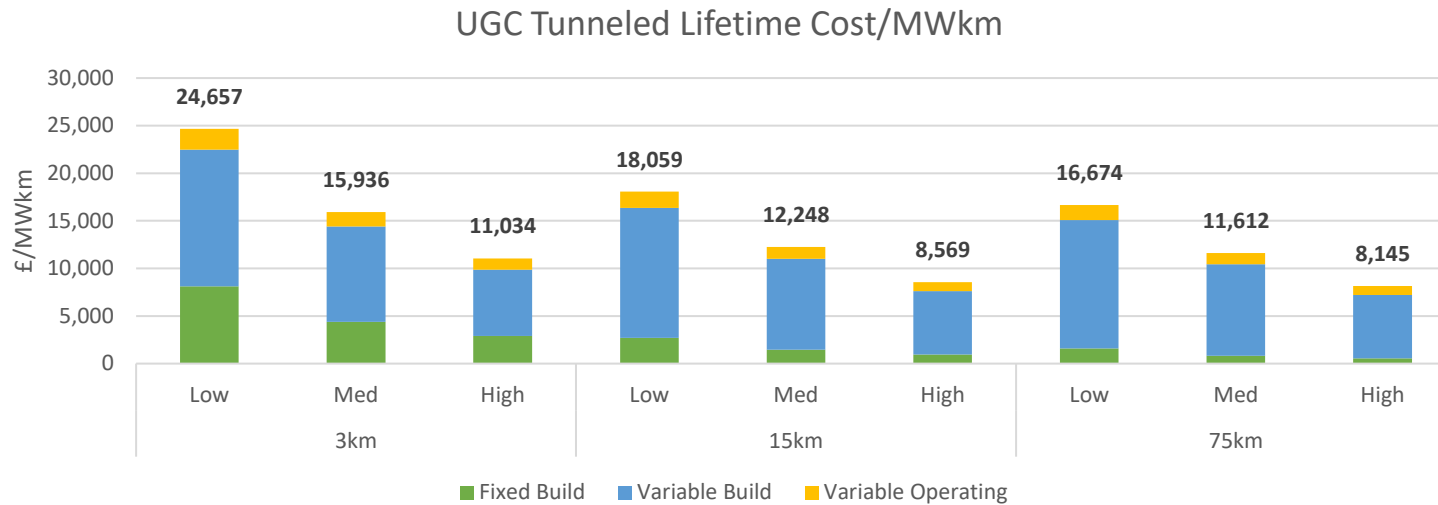

From the figures above we can see that the medium rated construction is around 1.1 to 1.4 times the cost of the low. This is as a result of increasing the tunnel diameter from 3 m to 4 m, and also doubling the number of conductors per phase. However, the ratio of lifetime cost between the high and medium ratings is around 0.69. This is due to the fact that the 4 m tunnel diameter and the number of conductors, are both the same as for the medium case, with cost increases primarily as a result of the forced ventilation system. However, the initial capital cost of constructing a cable system in a tunnel is very high, with costs between £108m and £243m for a short route length, £390m, and £1,085m for a medium route length, and £1,750m and £4,247m for a long route length. This is between two and ten times higher than the build cost of an underground cable system.

Offshore HVAC Submarine Cable – 90 km – Low Rating (500 MW)

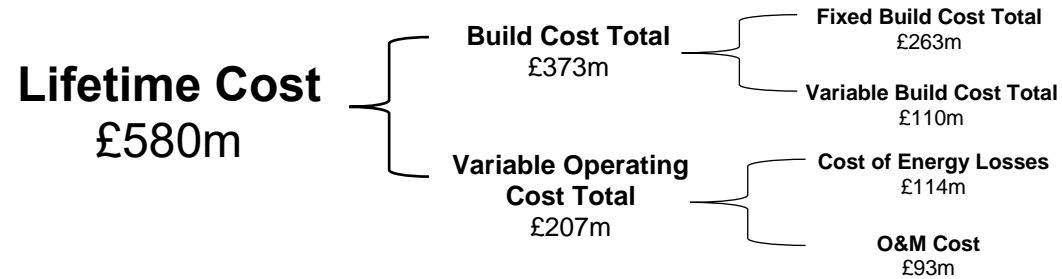

Lifetime Cost per km	£6.45m/km
Lifetime Power Transfer Cost per km	£12,891/MWkm

Data Source: [public domain data](#)

90km Low (500MW) (£580.1m)

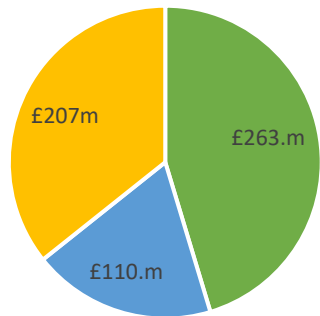

- Fixed Build - £263m (45.3%)
- Variable Build - £110m (19%)
- Variable Operating - £207m (35.7%)

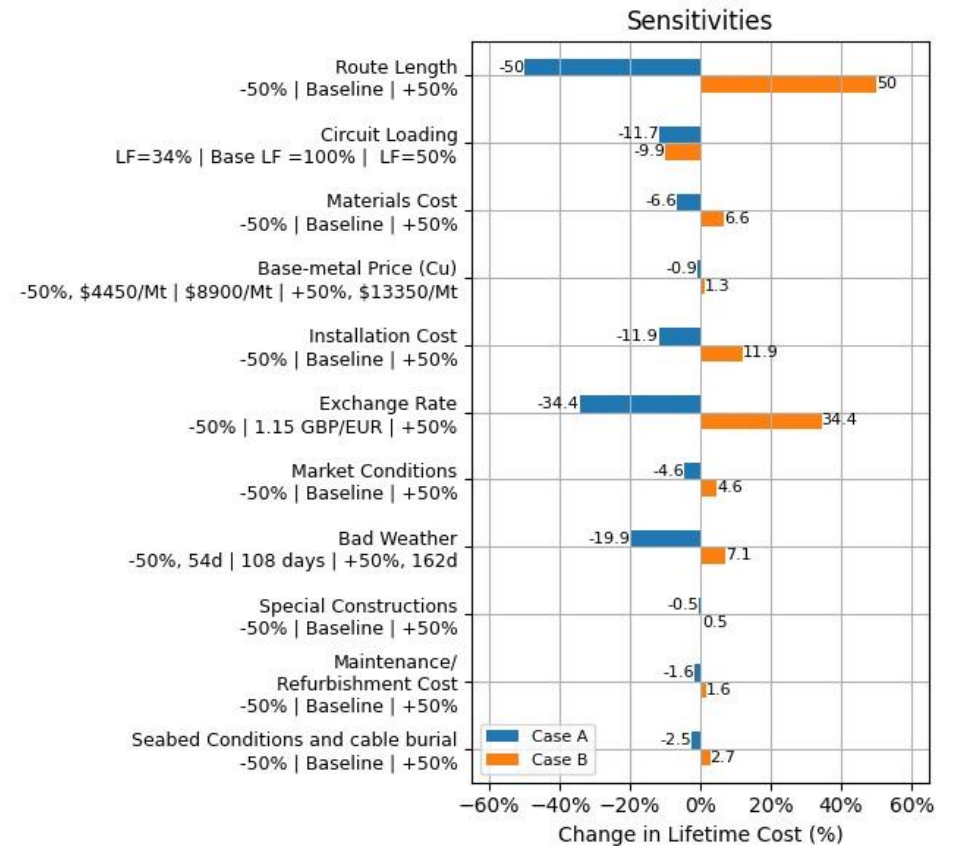

Offshore HVAC Submarine Cable – 90 km – Medium Rating (1,000 MW)

Lifetime Cost
£1,264m

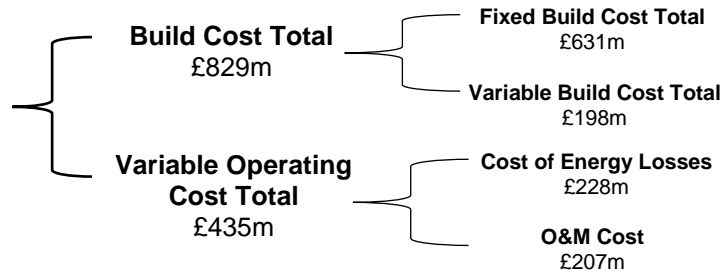

Lifetime Cost per km	£14.04m/km
Lifetime Power Transfer Cost per km	£14,043/MWkm

Data Source: [public domain data](#)

90km Med (1000MW) (£1263.9m)

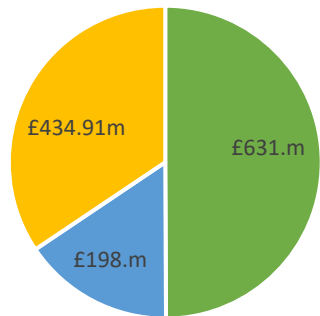

- Fixed Build - £631m (49.9%)
- Variable Build - £198m (15.7%)
- Variable Operating - £435m (34.4%)

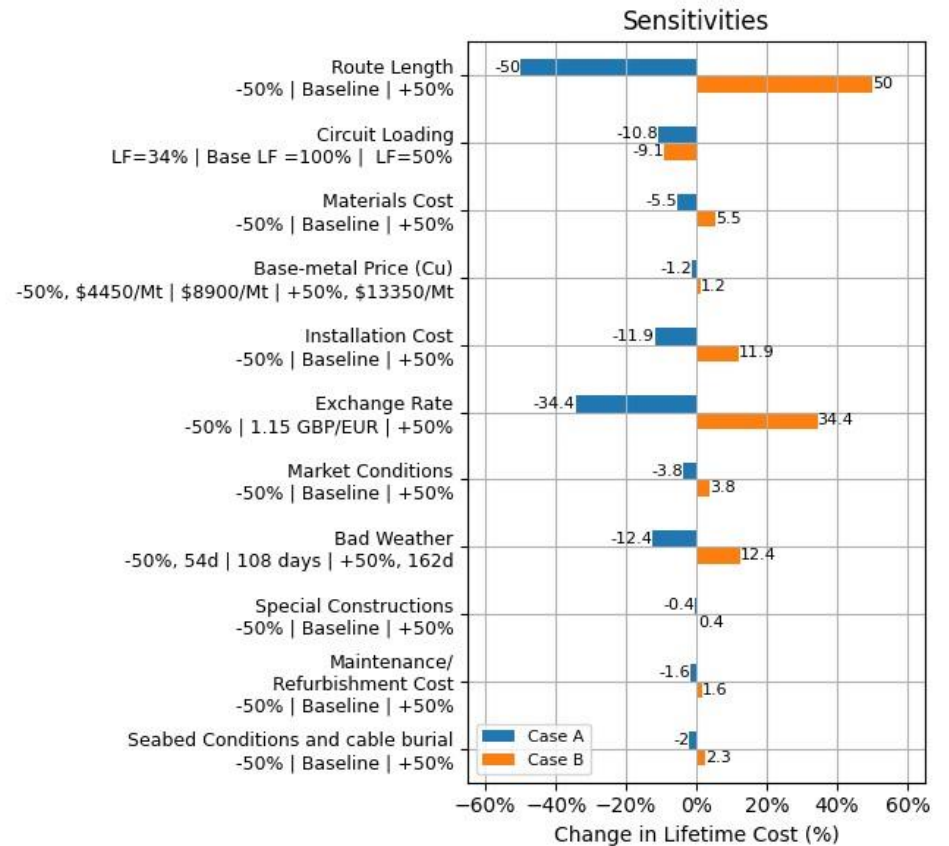

Offshore HVAC Submarine Cable – 90 km – High Rating (2,000 MW)

Lifetime Cost
£2,660m

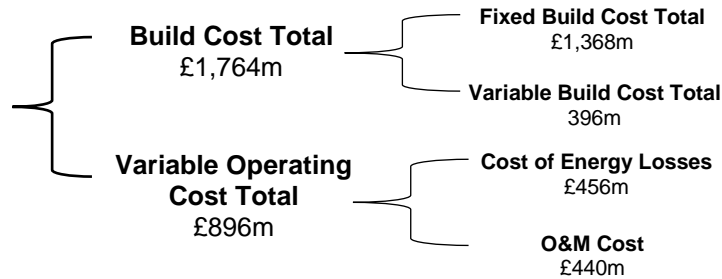

Lifetime Cost per km	£29.56m/km
Lifetime Power Transfer Cost per km	£14,779/MWkm

Data Source: [public domain data](#)

90km High (2000MW) (£2660.3m)

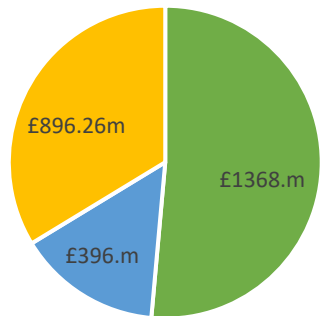

- Fixed Build - £1368m (51.4%)
- Variable Build - £396m (14.9%)
- Variable Operating - £896m (33.7%)

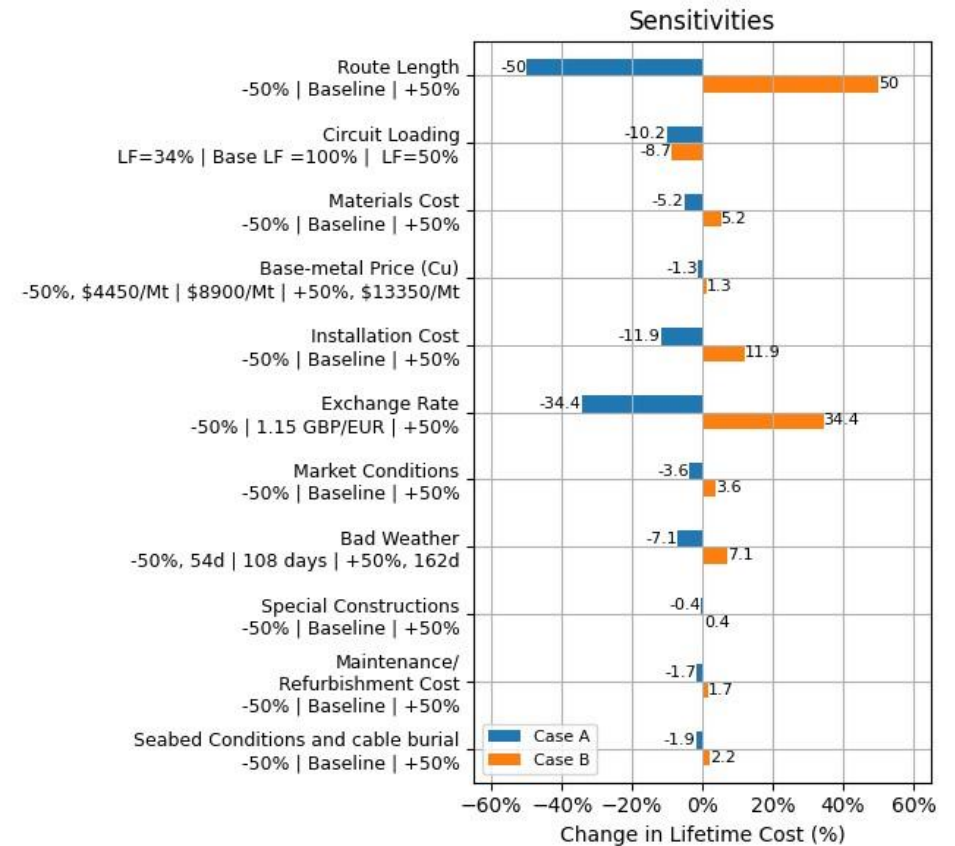

Offshore HVAC Submarine Cable – 180 km – Low Rating (500 MW)

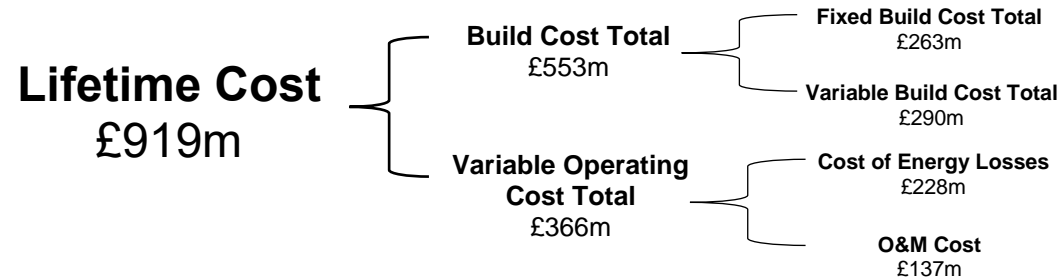

Lifetime Cost per km	£5.11m/km
Lifetime Power Transfer Cost per km	£10,212/MWkm

Data Source: [public domain data](#)

180km Low (500MW) (£919.1m)

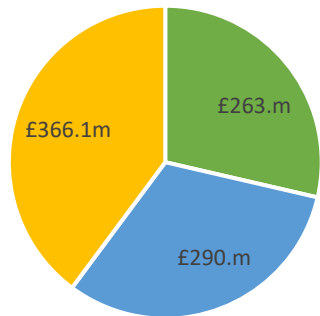

- Fixed Build - £263m (28.6%)
- Variable Build - £290m (31.6%)
- Variable Operating - £366m (39.8%)

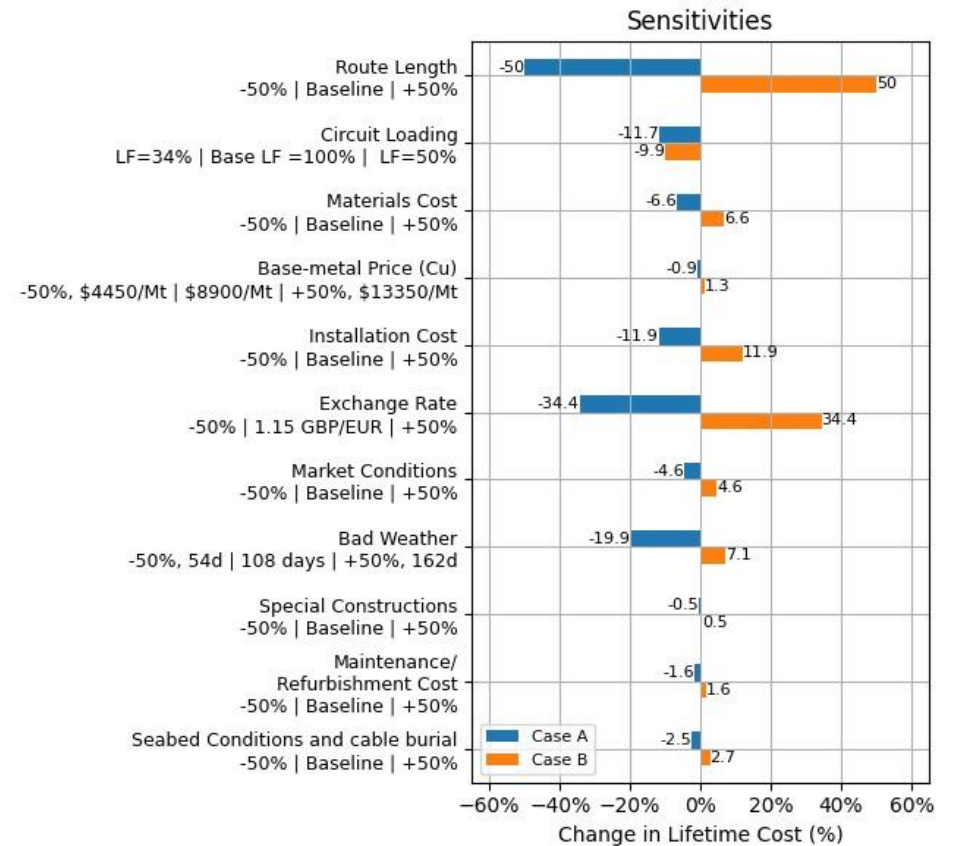

Offshore HVAC Submarine Cable – 180 km – Medium Rating (1,000 MW)

Lifetime Cost
£1,868m

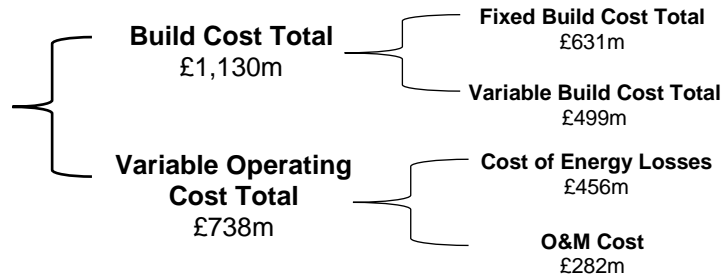

Lifetime Cost per km	£10.38m/km
Lifetime Power Transfer Cost per km	£10,379/MWkm

Data Source: [public domain data](#)

180km Med (1000MW) (£1868.2m)

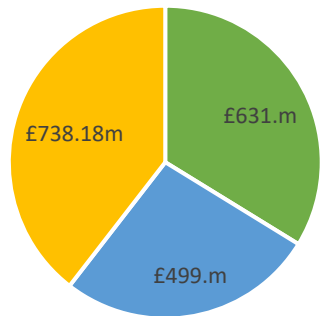

- Fixed Build - £631m (33.8%)
- Variable Build - £499m (26.7%)
- Variable Operating - £738m (39.5%)

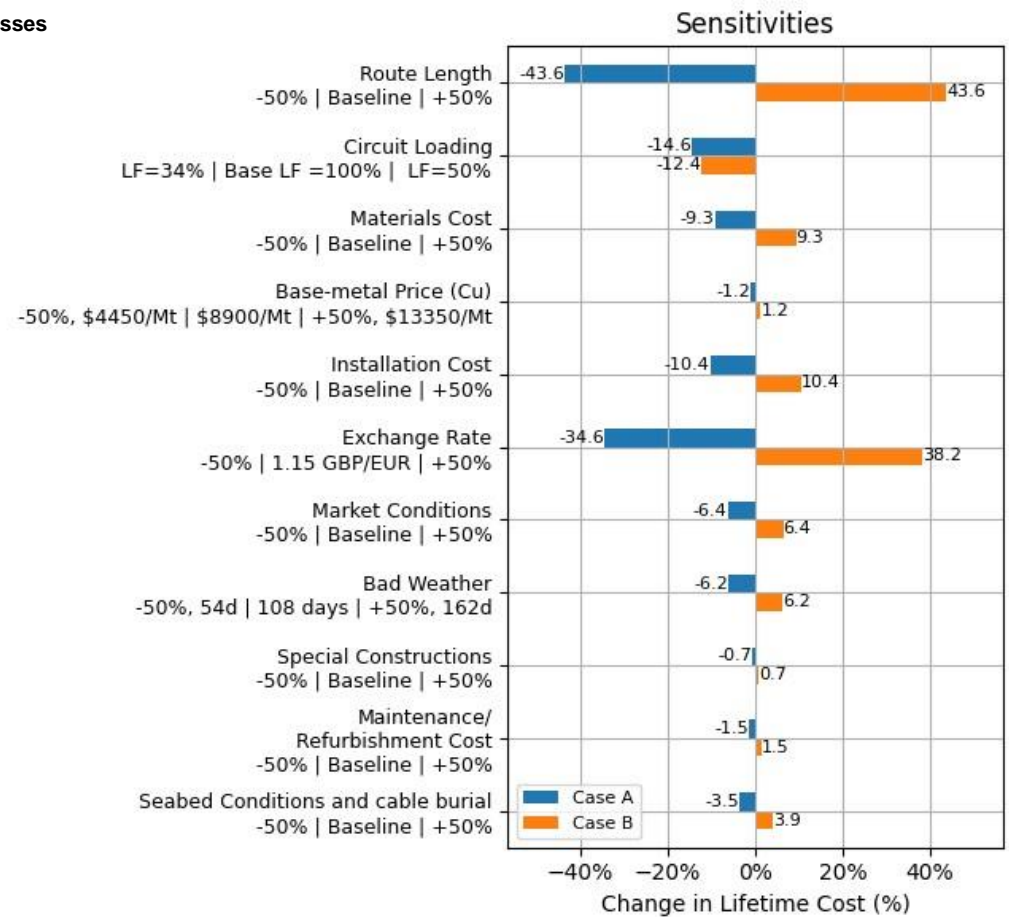

Offshore HVAC Submarine Cable – 180 km – High Rating (2,000 MW)

Lifetime Cost
£3,870m

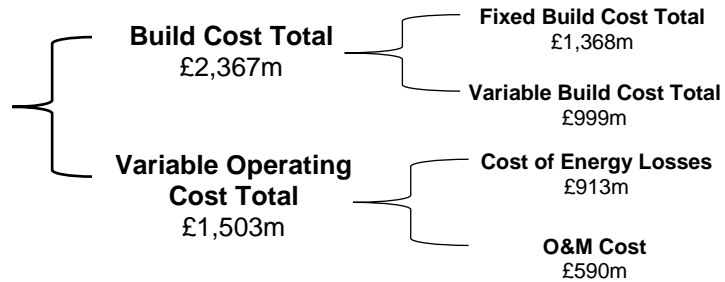

Lifetime Cost per km	£21.50m/km
Lifetime Power Transfer Cost per km	£10,750/MWkm

Data Source: [public domain data](#)

180km High (2000MW) (£3870m)

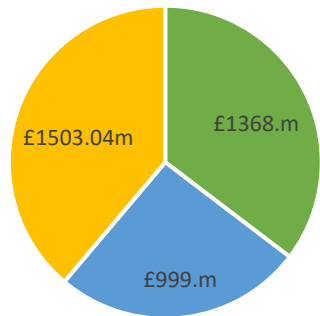

- Fixed Build - £1368m (35.3%)
- Variable Build - £999m (25.8%)
- Variable Operating - £1503m (38.8%)

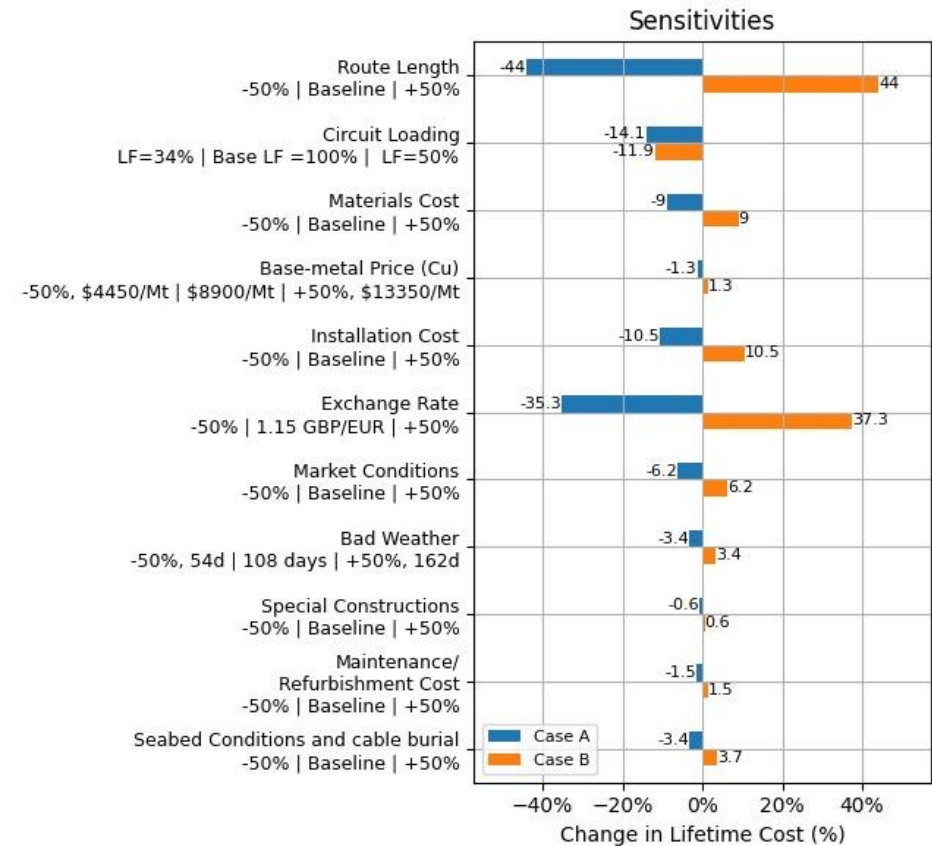

Offshore HVAC Submarine Cable – 275 km – Low Rating (500 MW)

Lifetime Cost
£1,266m

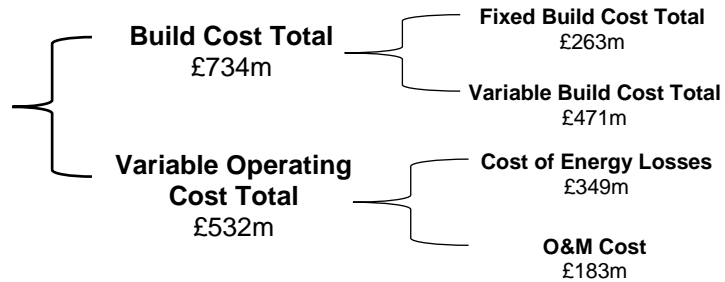

Lifetime Cost per km	£4.60m/km
Lifetime Power Transfer Cost per km	£9,205/MWkm

Data Source: [public domain data](#)

275km Low (500MW) (£1265.7m)

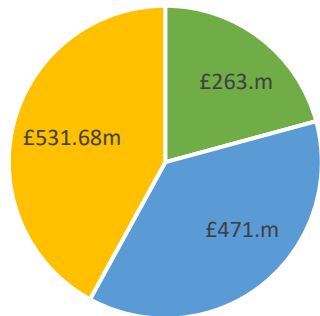

- Fixed Build - £263m (20.8%)
- Variable Build - £471m (37.2%)
- Variable Operating - £532m (42%)

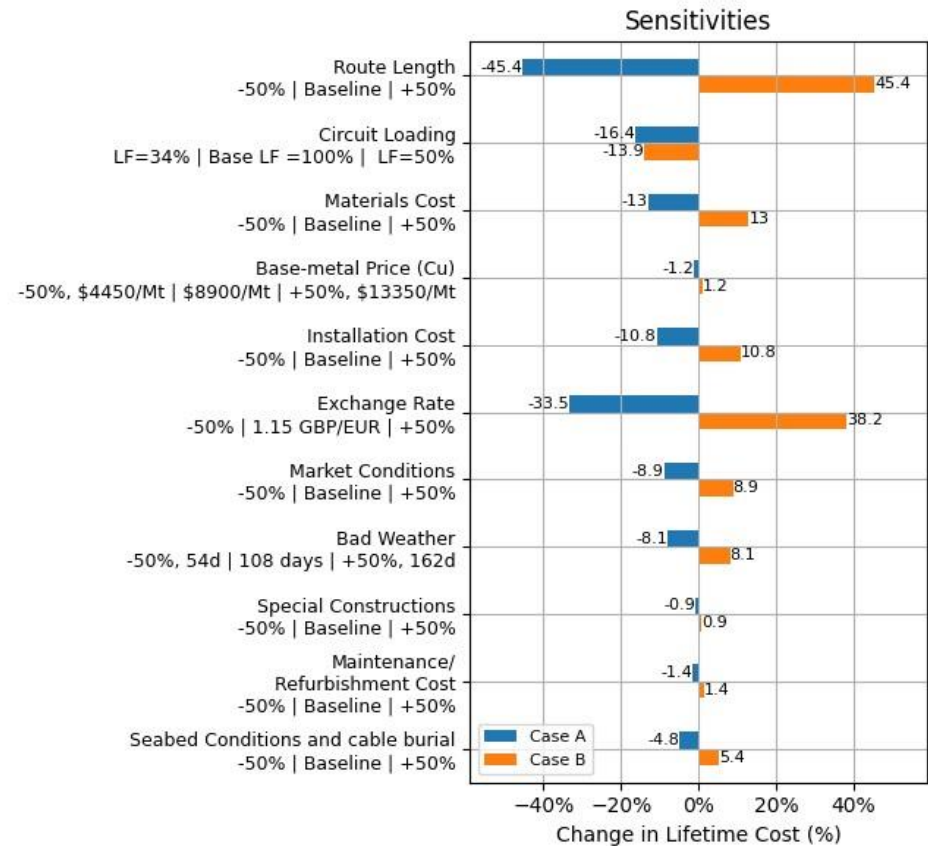

Offshore HVAC Submarine Cable – 275 km – Medium Rating (1,000 MW)

Lifetime Cost
£2,488m

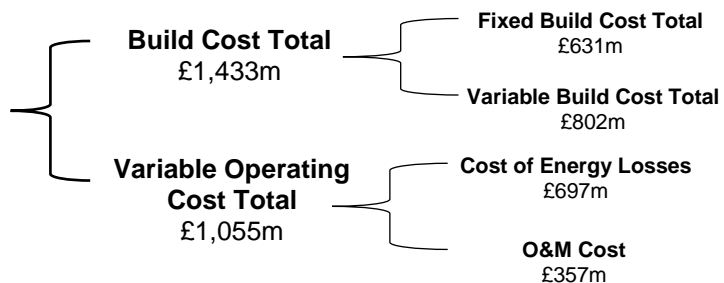

Lifetime Cost per km	£9.05m/km
Lifetime Power Transfer Cost per km	£9,046/MWkm

Data Source: [public domain data](#)

275km Med (1000MW) (£2487.6m)

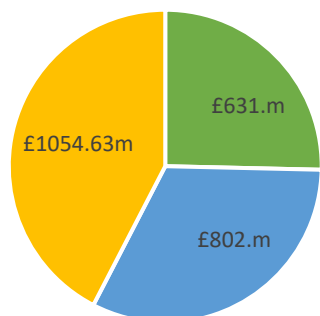

- Fixed Build - £631m (25.4%)
- Variable Build - £802m (32.2%)
- Variable Operating - £1055m (42.4%)

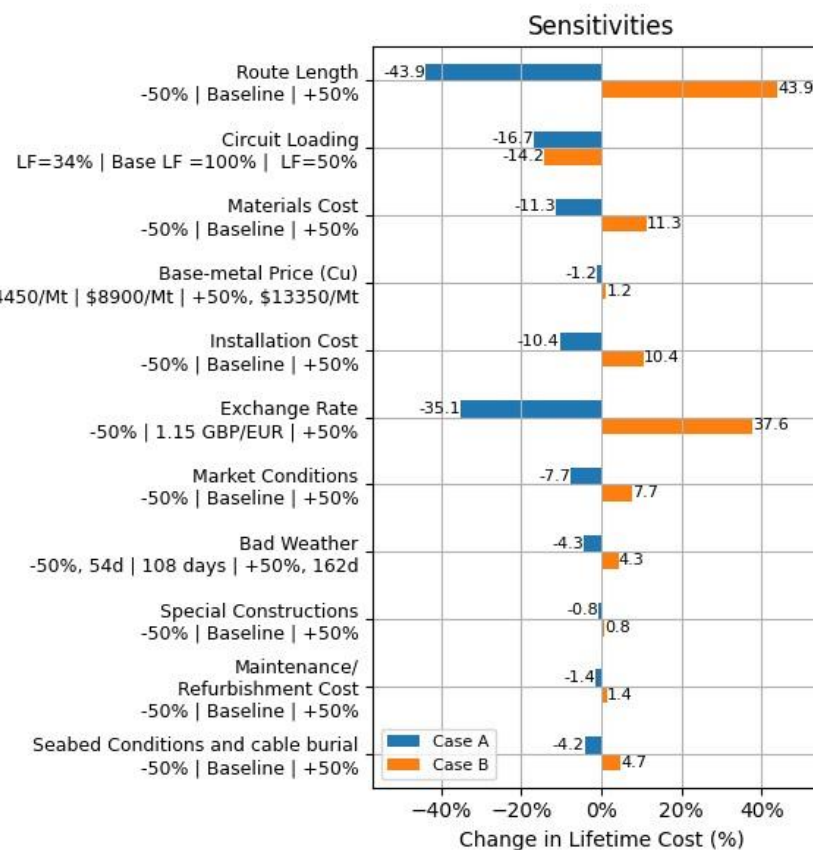

Offshore HVAC Submarine Cable – 275 km – High Rating (2,000 MW)

Lifetime Cost
£5,109m

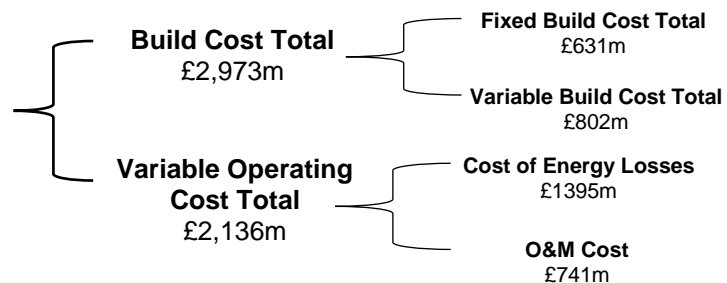

Lifetime Cost per km	£18.58m/km
Lifetime Power Transfer Cost per km	£9,289/MWkm

Data Source: [public domain data](#)

275km High (2000MW) (£5108.9m)

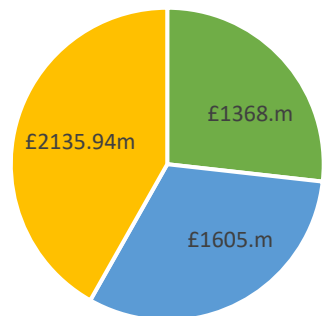

- Fixed Build - £1368m (26.8%)
- Variable Build - £1605m (31.4%)
- Variable Operating - £2136m (41.8%)

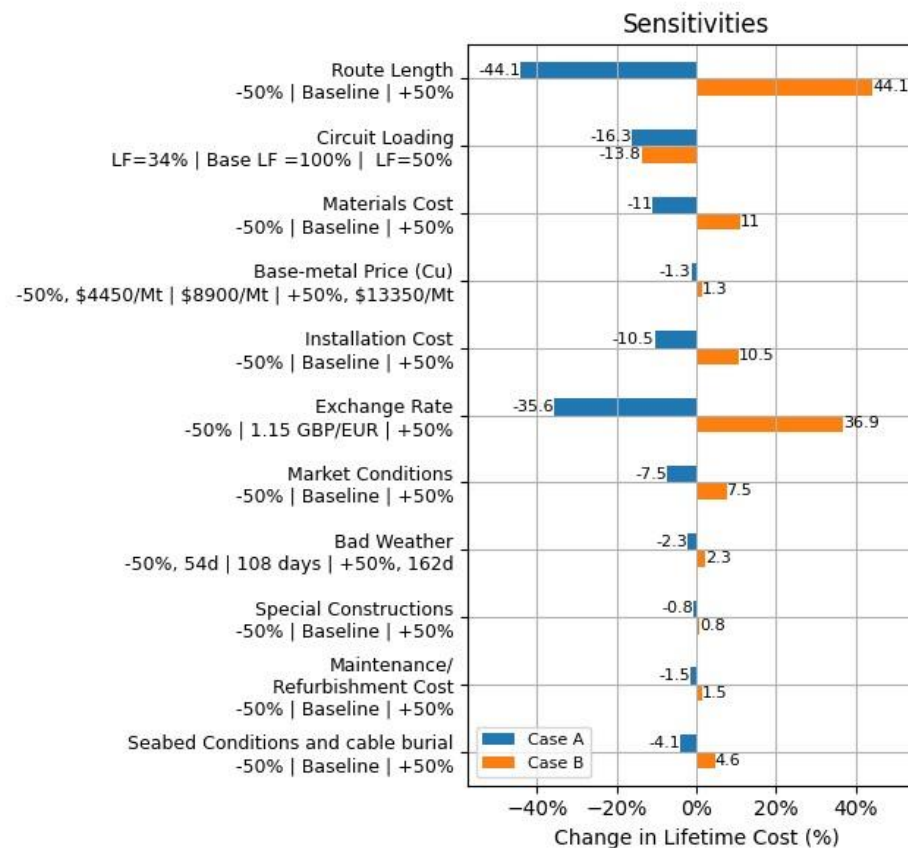

HVAC Lifetime Cost £m

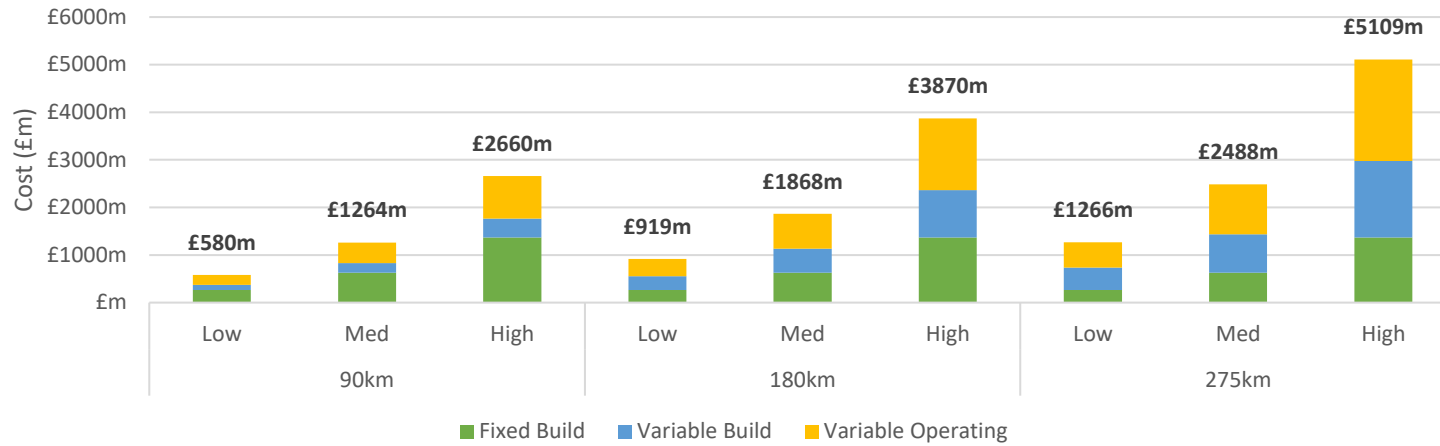

HVAC Lifetime Cost £m/km

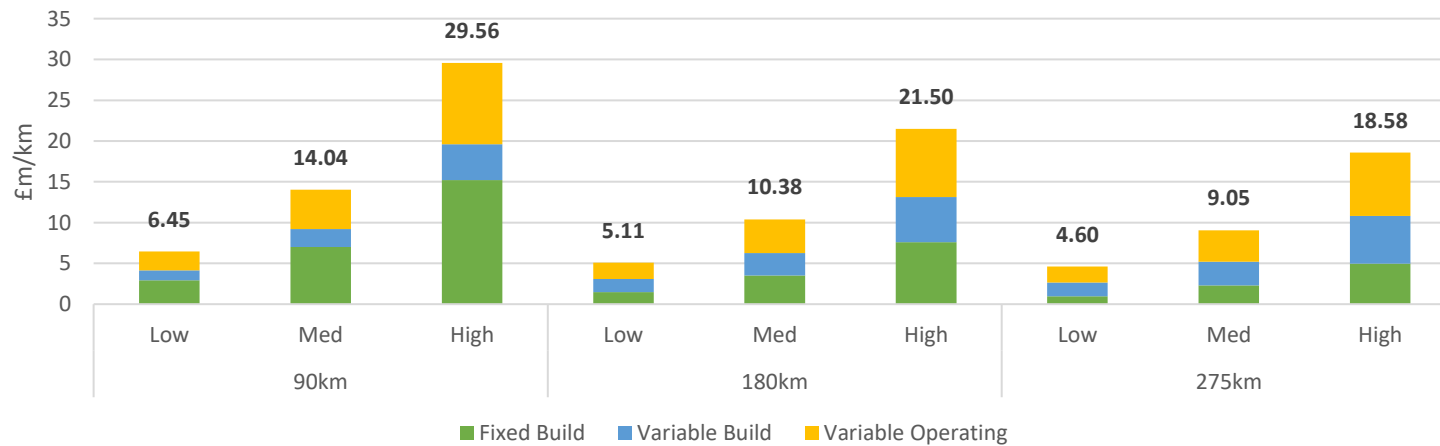

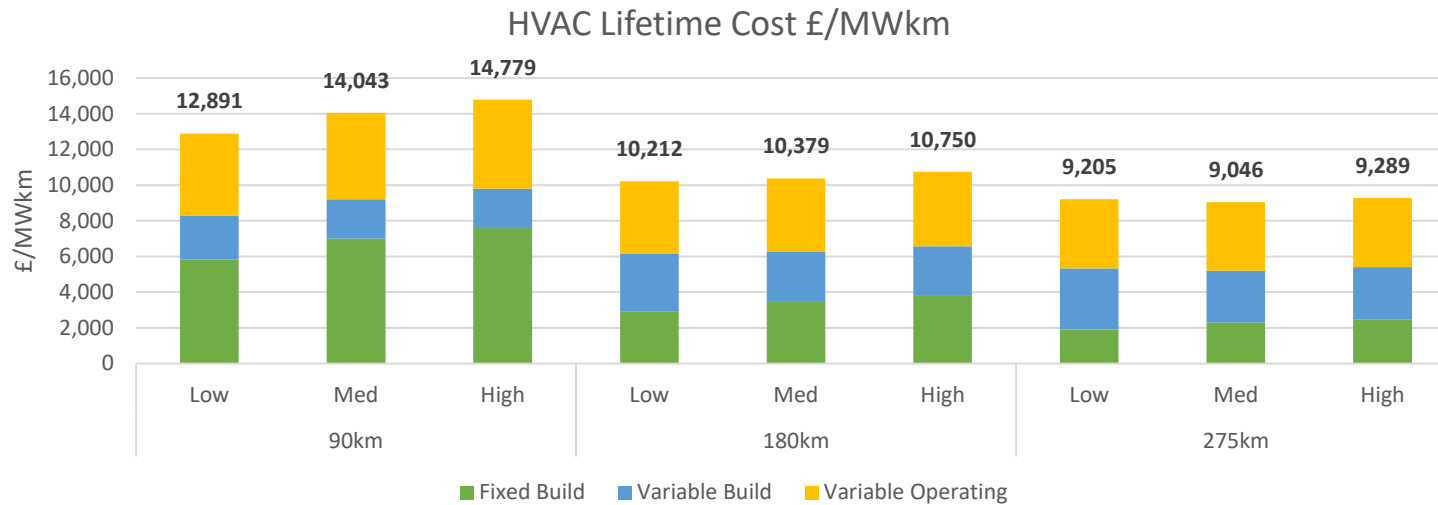

From the figures above we can see that the medium rated construction is around 2 to 2.2 times the cost of the low, and the same applies for high and medium. However, when the amount of power which is transferred is considered it shows that for the medium and high route length the lifetime costs are similar irrespective of rating. In this instance we are doubling the quantity of conductors for each rating increment, but also doubling the power transfer capacity, and thus the losses are even across a given route length. For the short route lengths there is a high upfront capital cost which is dominant. However, when considering the longer route lengths, this is less pronounced and is also balanced out by some economies of scale in respect of cable costs.

HVDC VSC Onshore-Offshore Radial Link – 90 km – Low Rating (500 MW)

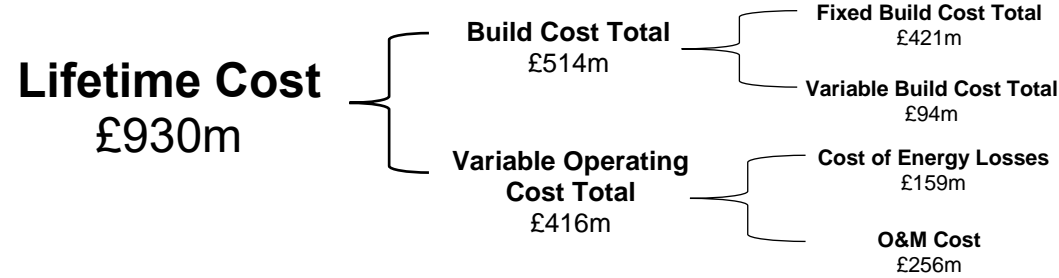

Lifetime Cost per km	£10.33m/km
Lifetime Power Transfer Cost per km	£20,662/MWkm

Data Source: [public domain data](#)

90km Low (500MW) (£929.8m)

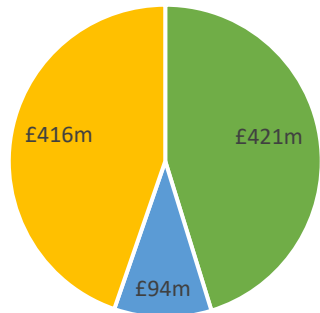

- Fixed Build - £421m (45.2%)
- Variable Build - £94m (10.1%)
- Variable Operating - £416m (44.7%)

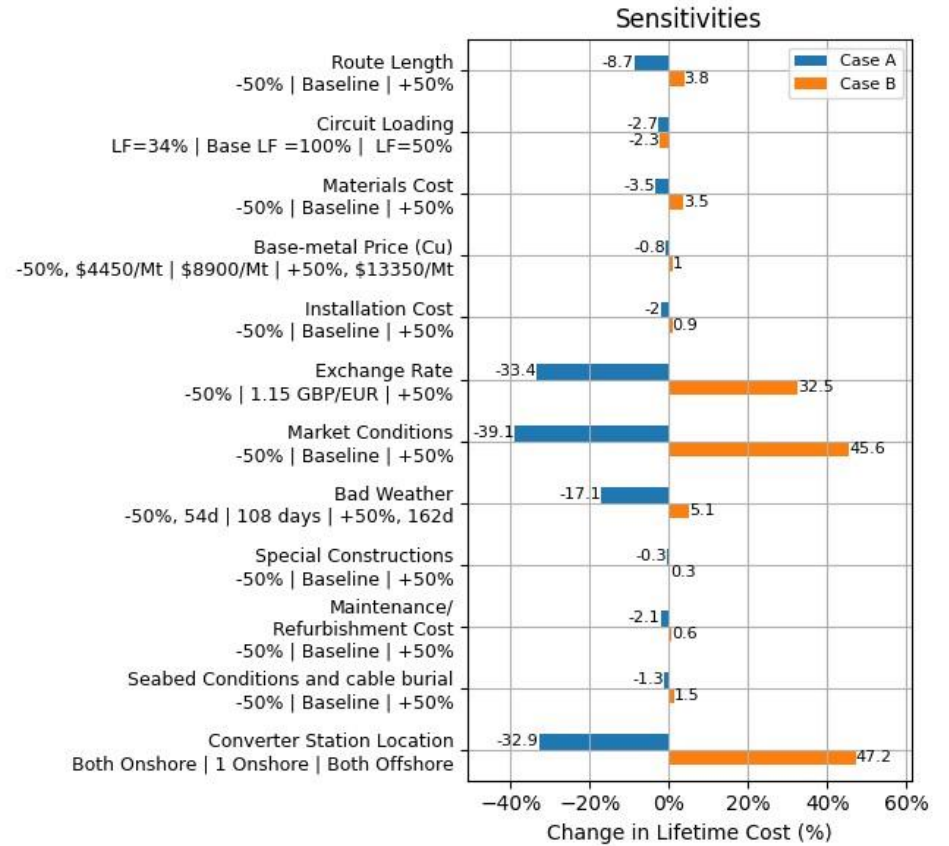

HVDC VSC Onshore-Offshore Radial Link – 90 km – Medium Rating (1,000 MW)

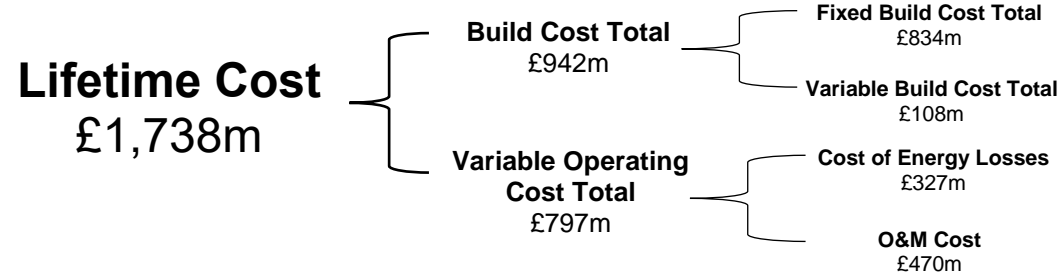

Lifetime Cost per km	£19.32m/km
Lifetime Power Transfer Cost per km	£19,317/MWkm

Data Source: [public domain data](#)

90km Med (1000MW) (£1738.5m)

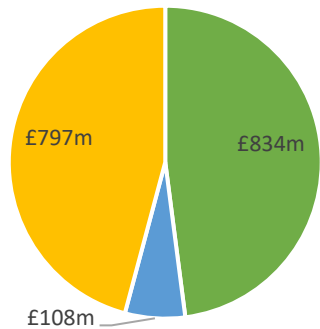

- Fixed Build - £834m (47.9%)
- Variable Build - £108m (6.2%)
- Variable Operating - £797m (45.8%)

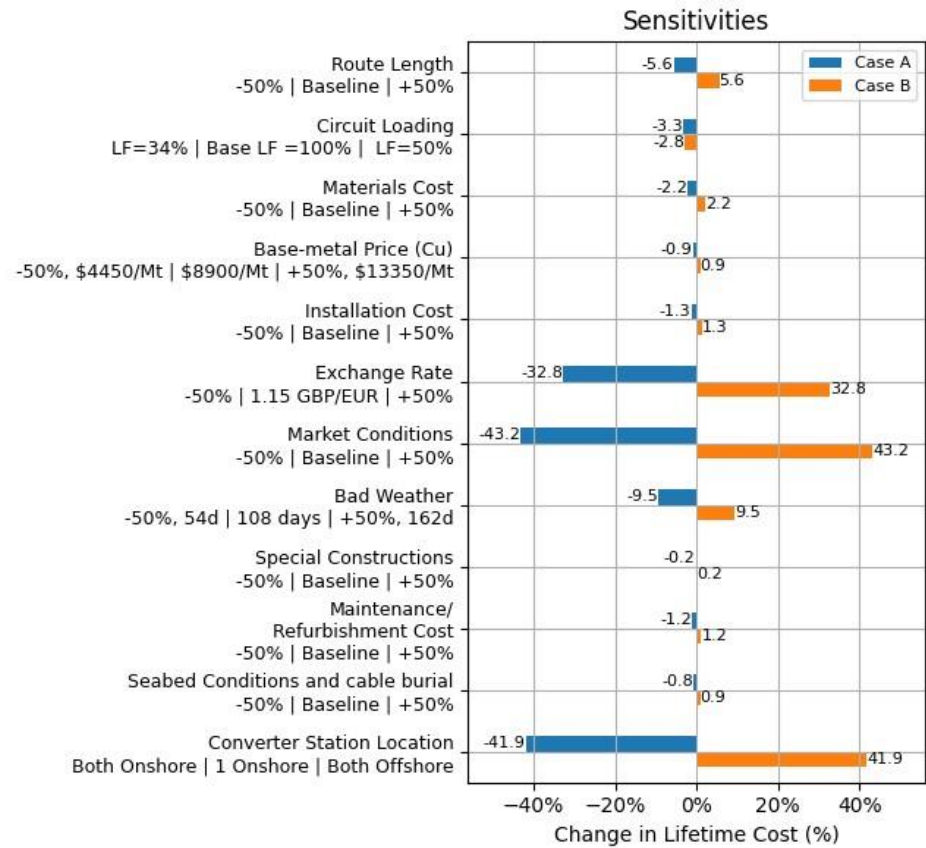

HVDC VSC Onshore-Offshore Radial Link – 90 km – High Rating (2,000 MW)

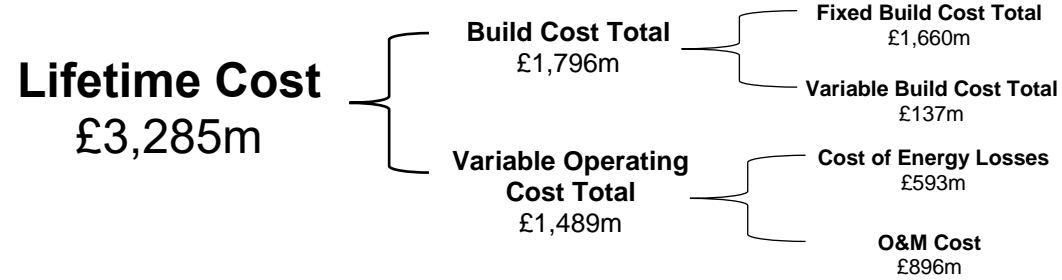

Lifetime Cost per km	£36.50m/km
Lifetime Power Transfer Cost per km	£18,252/MWkm

Data Source: [public domain data](#)

90km High (2000MW) (£3285.4m)

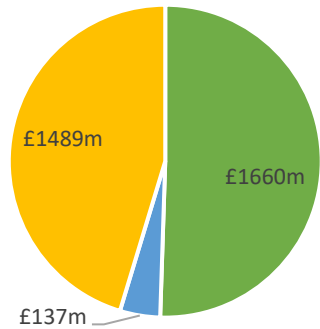

- Fixed Build - £1660m (50.5%)
- Variable Build - £137m (4.2%)
- Variable Operating - £1489m (45.3%)

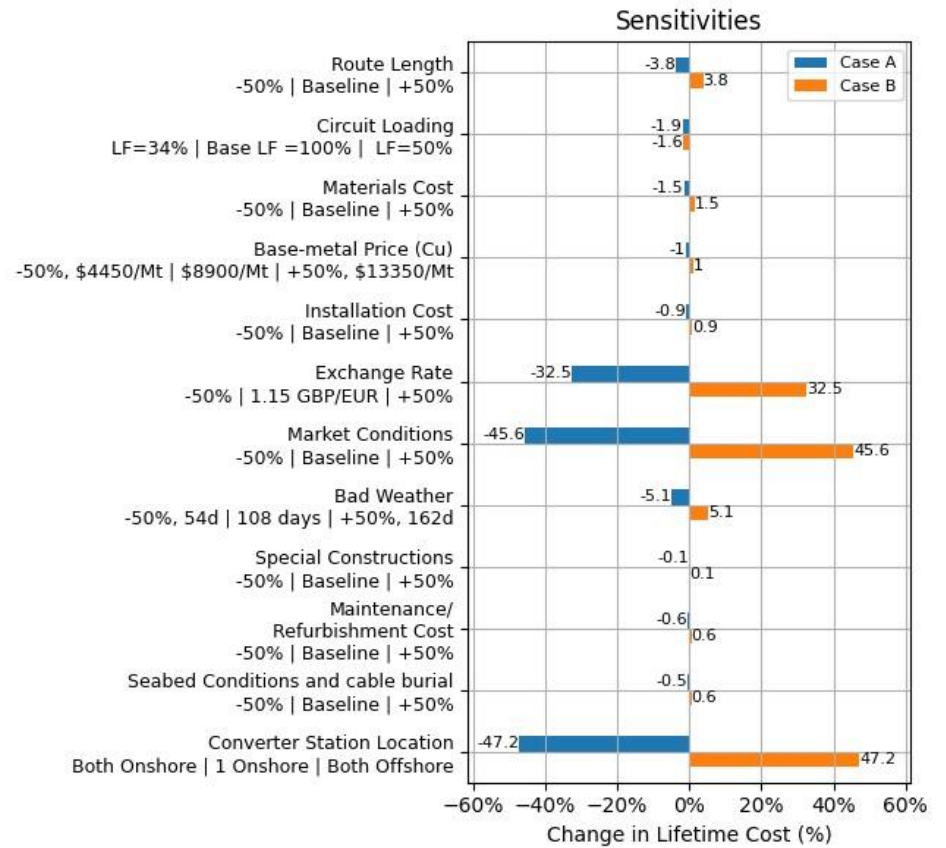

HVDC VSC Onshore-Offshore Radial Link – 180 km – Low Rating (500 MW)

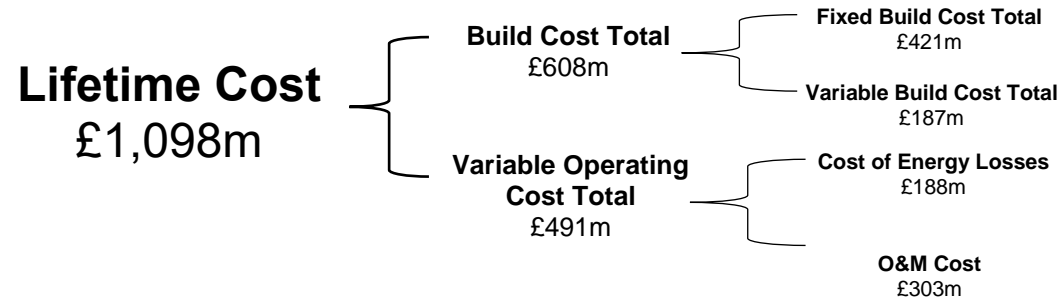

Lifetime Cost per km	£6.10m/km
Lifetime Power Transfer Cost per km	£12,204/MWkm

Data Source: [public domain data](#)

180km Low (500MW) (£1098.3m)

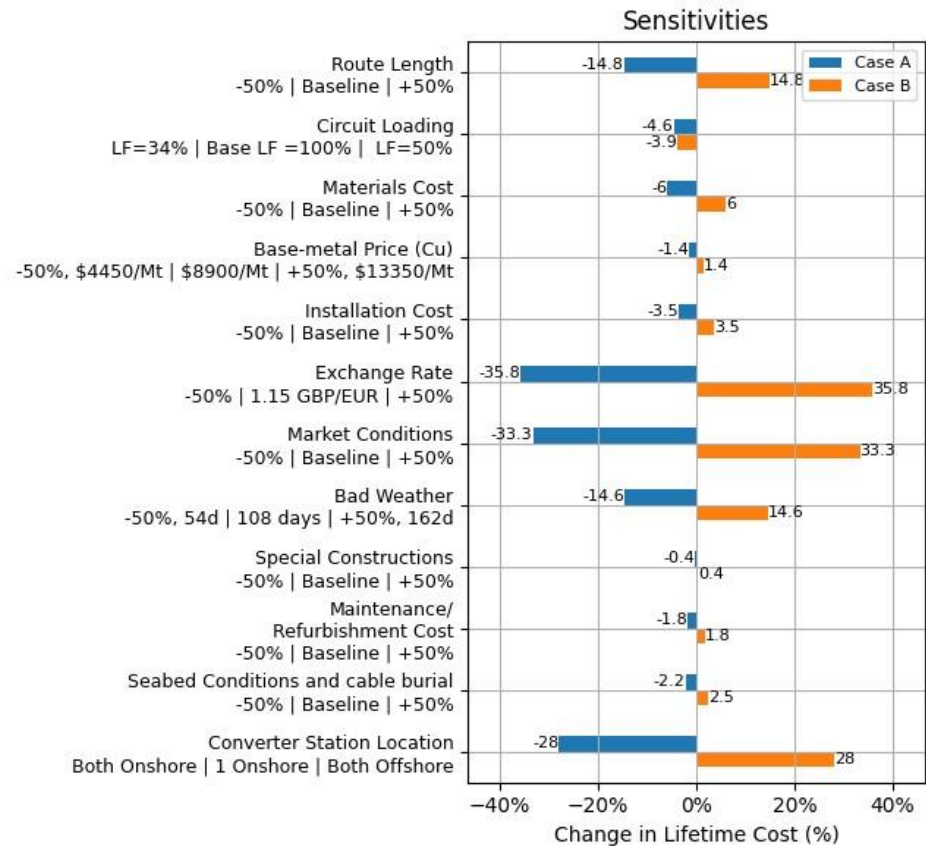
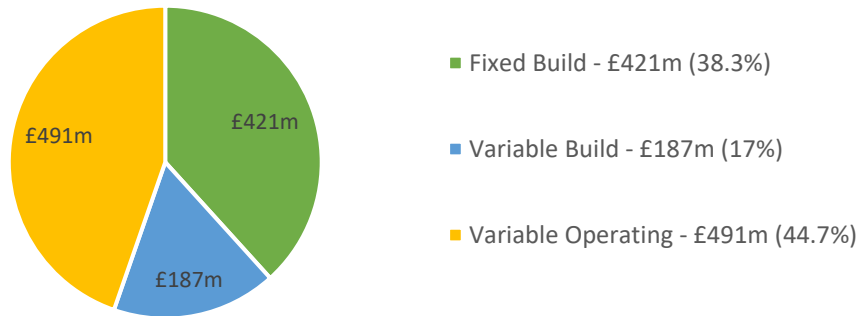

HVDC VSC Onshore-Offshore Radial Link – 180 km – High Rating (2,000 MW)

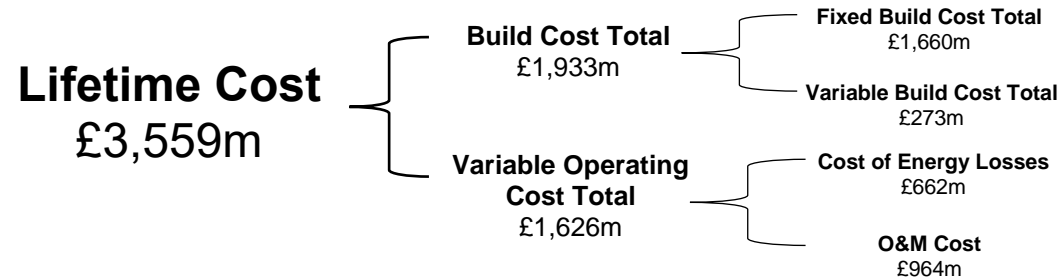

Lifetime Cost per km	£19.77m/km
Lifetime Power Transfer Cost per km	£9,887/MWkm

Data Source: [public domain data](#)

180km High (2000MW) (£3559.2m)

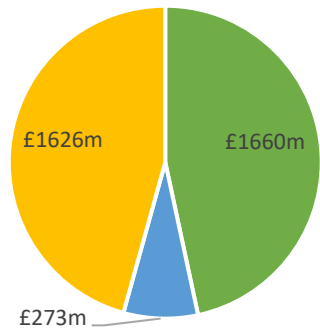

- Fixed Build - £1660m (46.6%)
- Variable Build - £273m (7.7%)
- Variable Operating - £1626m (45.7%)

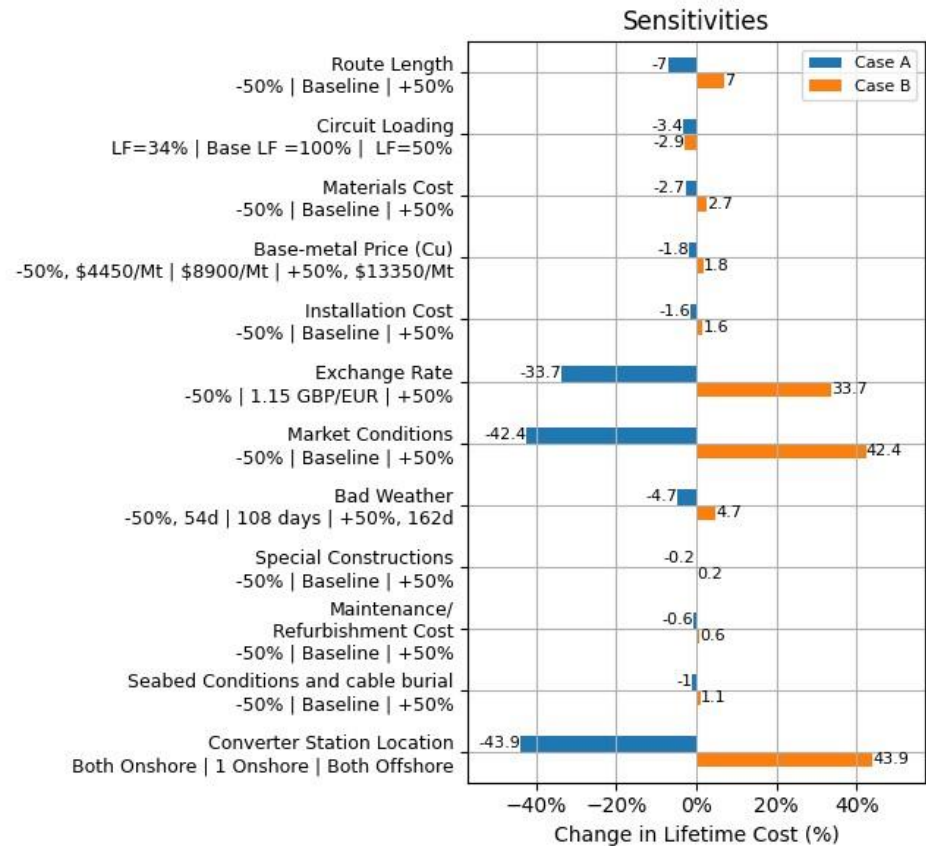

HVDC VSC Onshore-Offshore Radial Link – 275 km – Low Rating (500 MW)

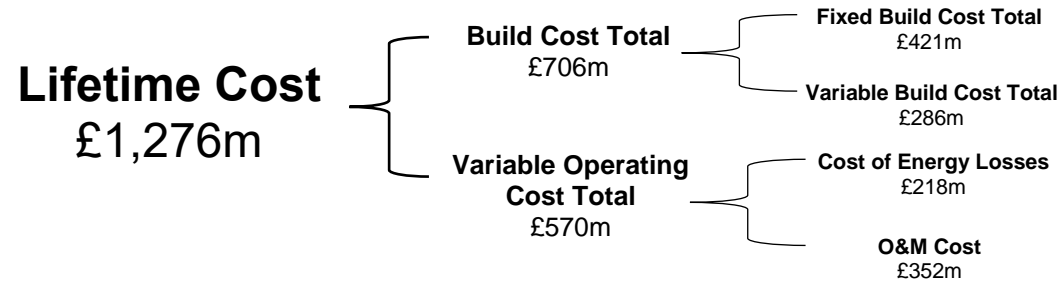

Lifetime Cost per km	£4.64m/km
Lifetime Power Transfer Cost per km	£9,282/MWkm

Data Source: [public domain data](#)

275km Low (500MW) (£1276.2m)

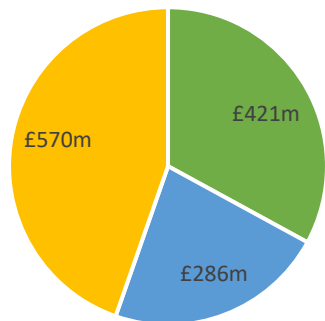

- Fixed Build - £421m (32.9%)
- Variable Build - £286m (22.4%)
- Variable Operating - £570m (44.7%)

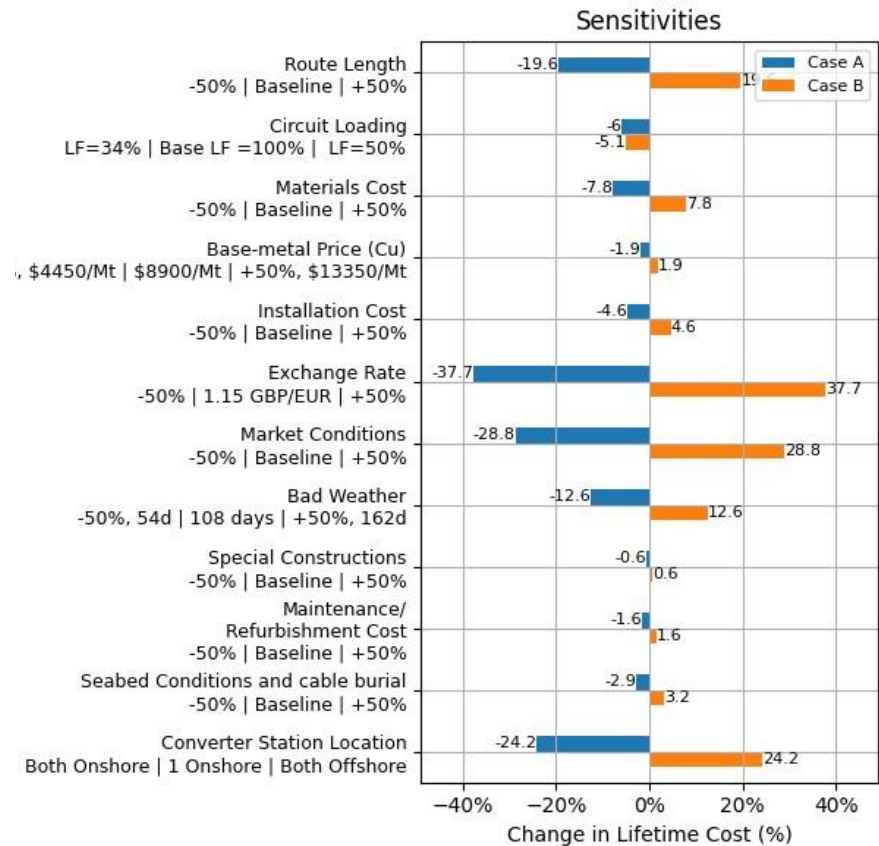

HVDC VSC Onshore-Offshore Radial Link – 275 km – Medium Rating (1,000 MW)

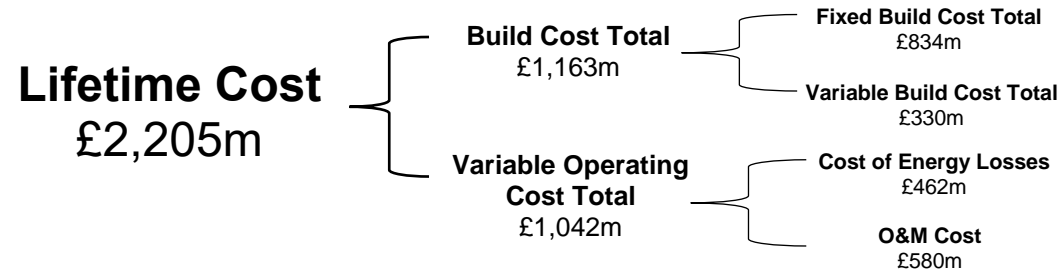

Lifetime Cost per km	£8.02m/km
Lifetime Power Transfer Cost per km	£8,019/MWkm

Data Source: [public domain data](#)

275km Med (1000MW) (£2205.4m)

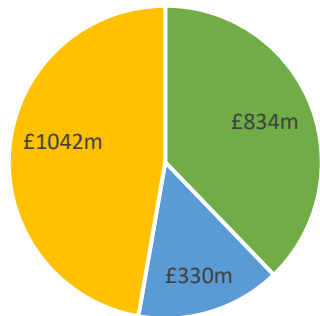

- Fixed Build - £834m (37.8%)
- Variable Build - £330m (15%)
- Variable Operating - £1,042m (47.2%)

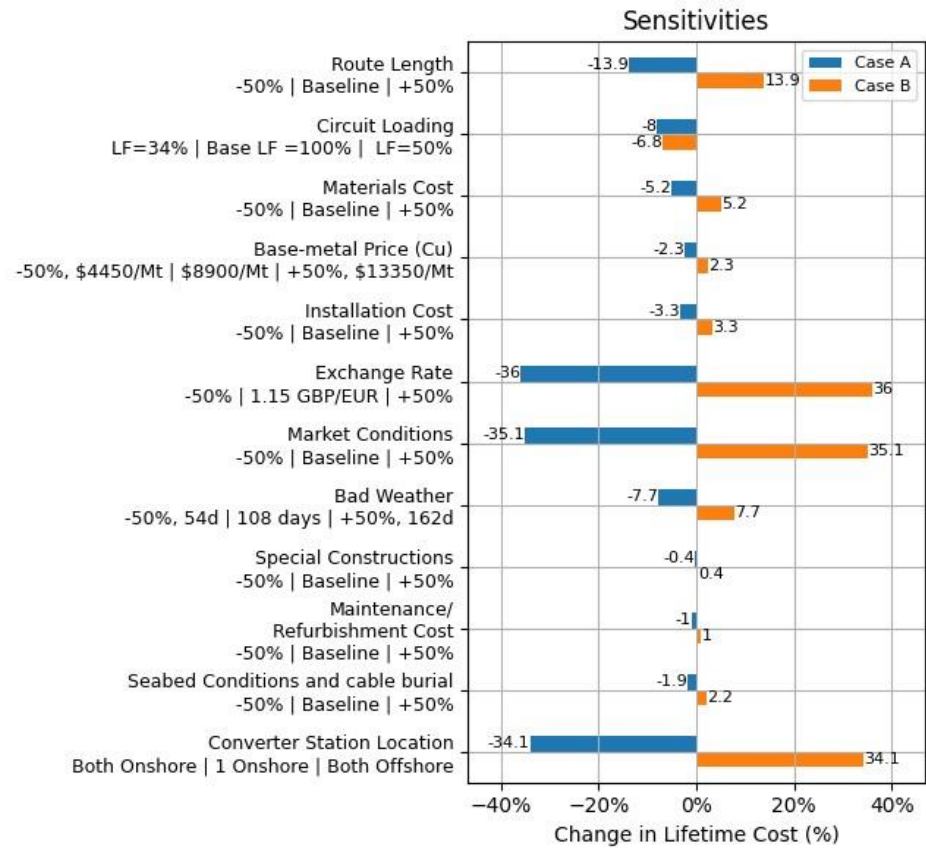

HVDC VSC Onshore-Offshore Radial Link – 275 km – High Rating (2,000 MW)

Lifetime Cost
£3,848m

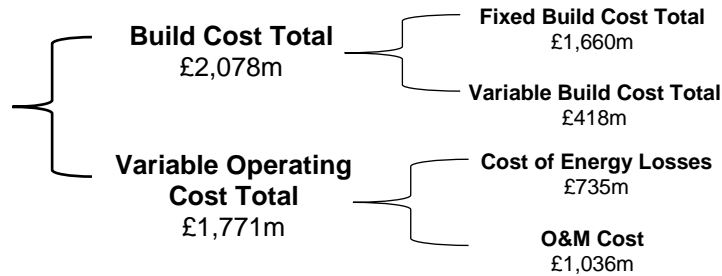

Lifetime Cost per km	£13.99m/km
Lifetime Power Transfer Cost per km	£6,997/MWkm

Data Source: [public domain data](#)

275km High (2000MW) (£3848.2m)

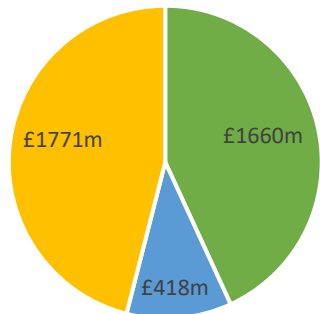

- Fixed Build - £1660m (43.1%)
- Variable Build - £418m (10.9%)
- Variable Operating - £1771m (46%)

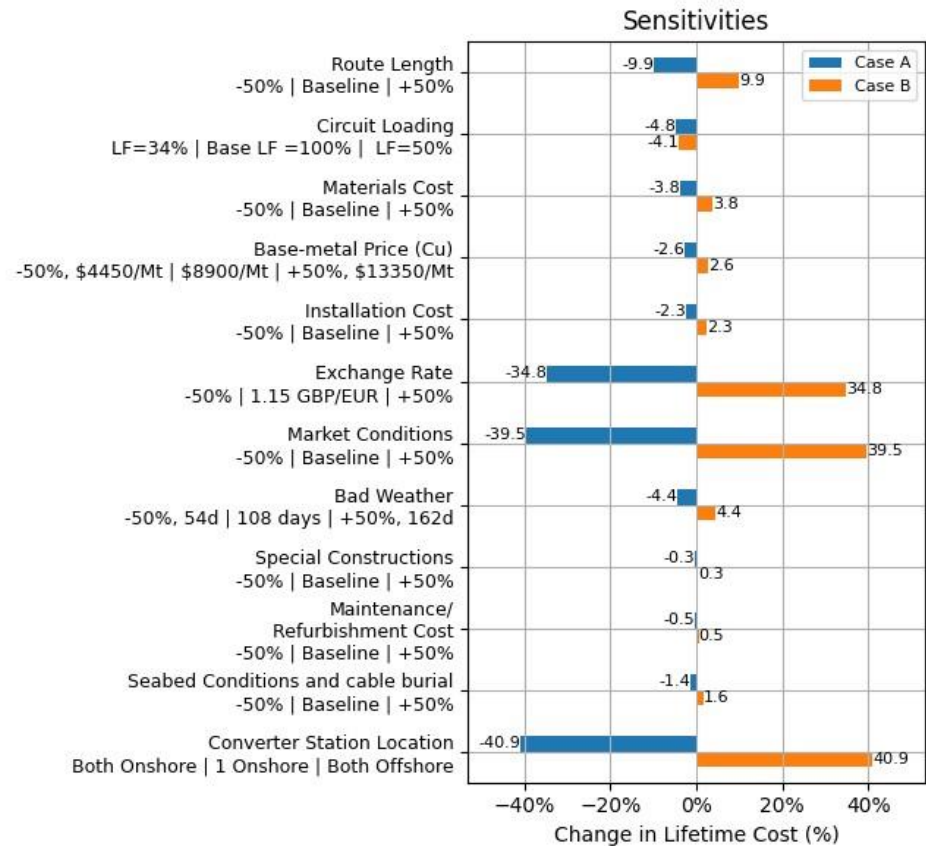

HVDC Lifetime Cost £m

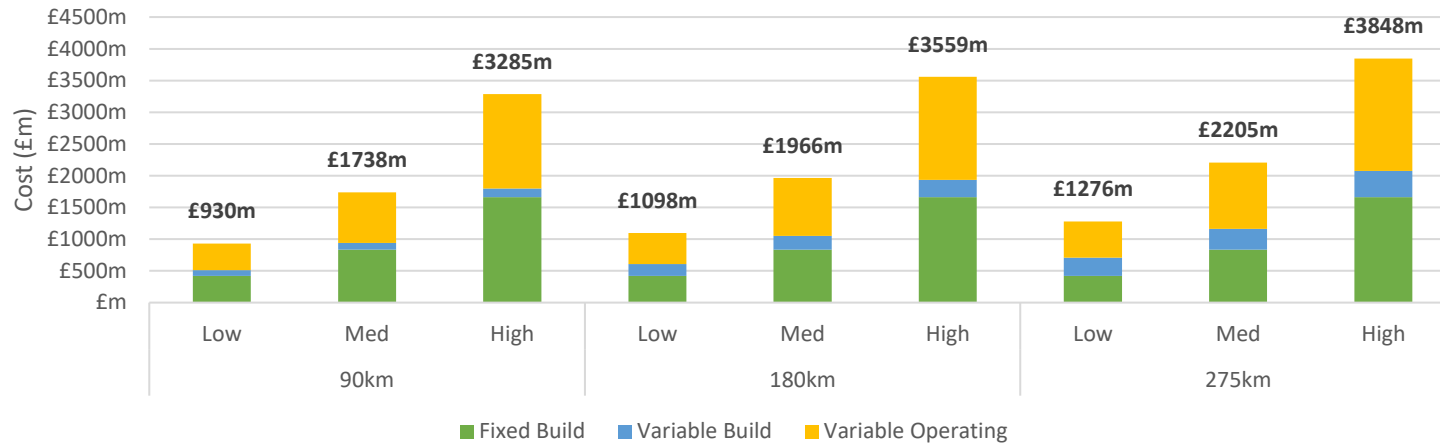

HVDC Lifetime Cost £m/km

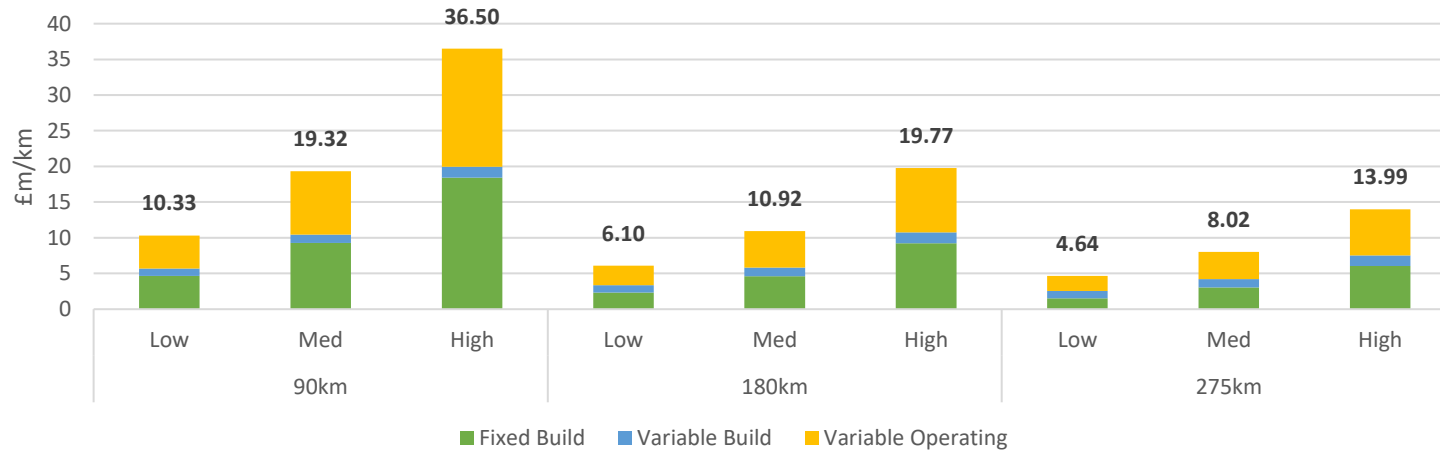

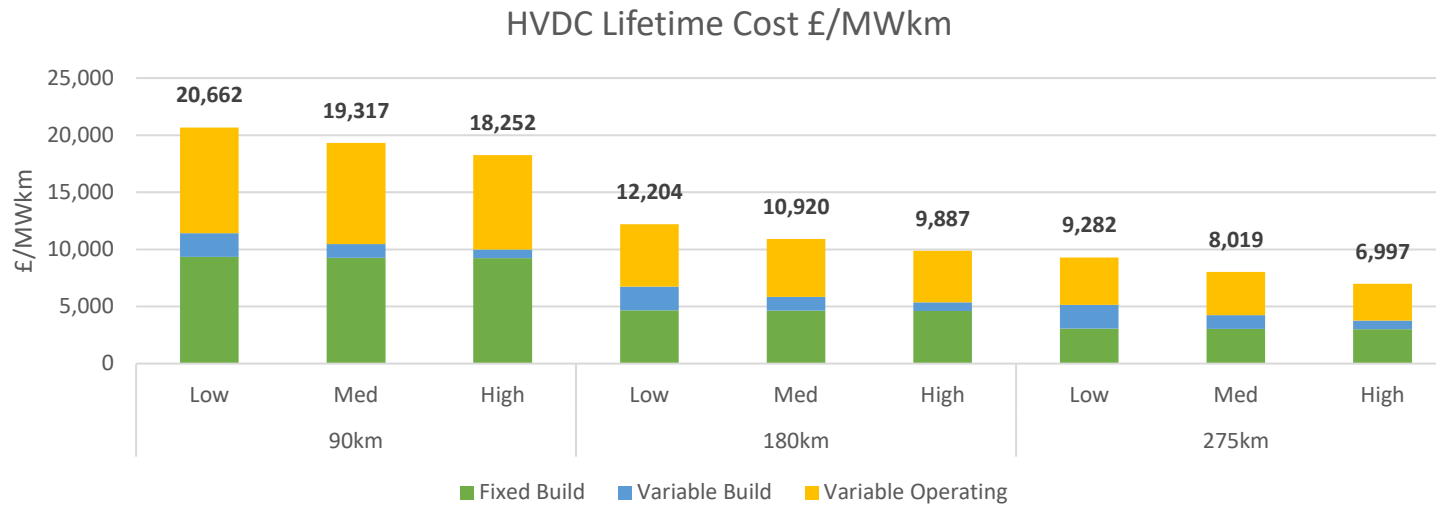

From the figures above we can see that the ratio of lifetime cost between the different ratings cases is similar for a given route length, but that efficiencies increase with route length. For the short route length the ration between medium/low and high/medium is around 0.94. For the medium route length it is approximately 0.9, and for the long route length it is around 0.86. Thus, the longer the route length, and the higher the amount of power to be transferred, the better value for money is achieved with this technology. This is because there is a high upfront capital cost for the technology, along with a fixed quantity of losses for each converter station. However, the variable losses as a result of the cable are relatively low, but a certain circuit length must be achieved in order for these to become a dominant factor. It should be noted that, in particular in the case of the 2 GW solution, costs are indicative as explained in Section C.3.1 due to a limited dataset, and as a result of such solutions not having been constructed yet.

HVDC VSC “embedded link” – 90 km – Rating 2,000 MW

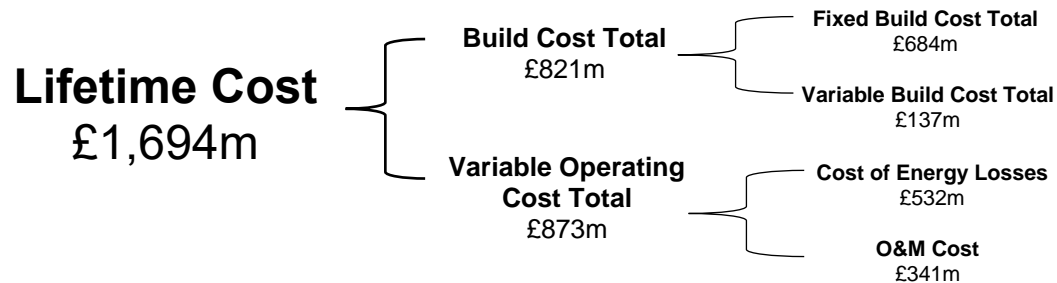

Lifetime Cost per km	£18.82m/km
Lifetime Power Transfer Cost per km	£9,411/MWkm

90km (2000MW) (£1694m)

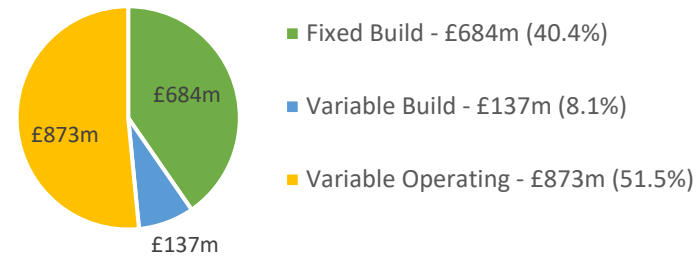

Data Source: public domain data

HVDC VSC “embedded link” – 180 km – (2,000 MW)

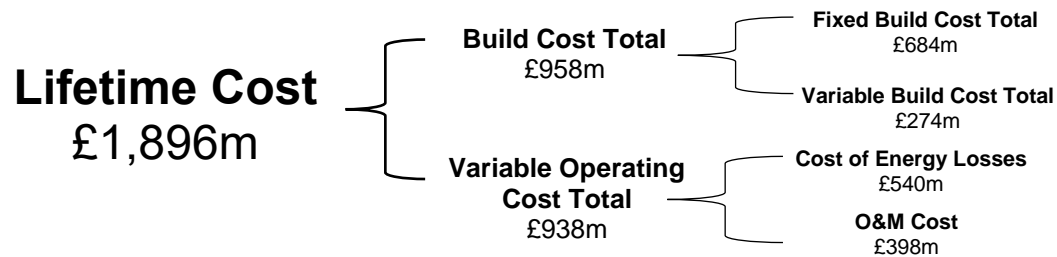

Lifetime Cost per km	£10.53m/km
Lifetime Power Transfer Cost per km	£5,266/MWkm

180km (2000MW) (£1895.7m)

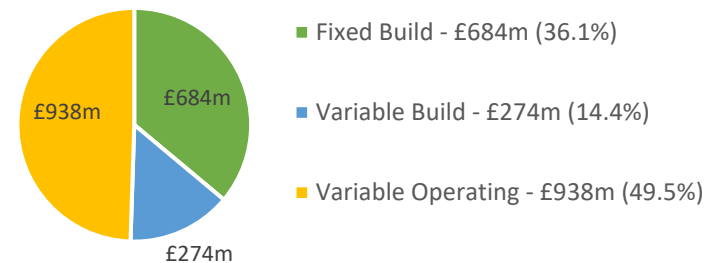

Data Source: public domain data

HVDC VSC “embedded link” – 275 km – (2,000 MW)

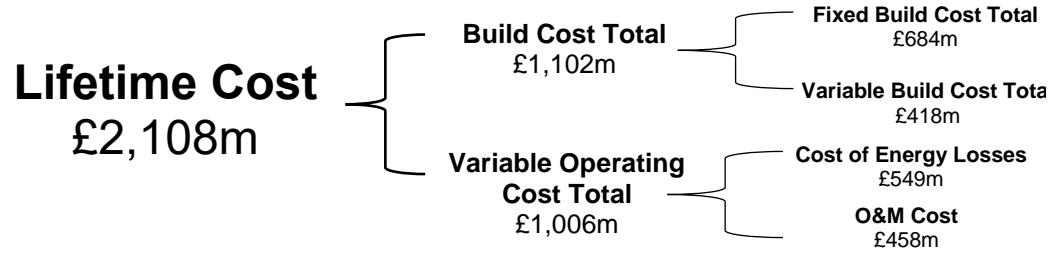

Lifetime Cost per km	£7.67m/km
Lifetime Power Transfer Cost per km	£3,834/MWkm

275km (2000MW) (£2108.5m)

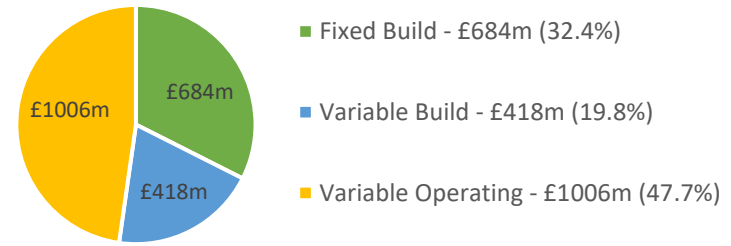

Data Source: public domain data

HVDC Lifetime Cost £m

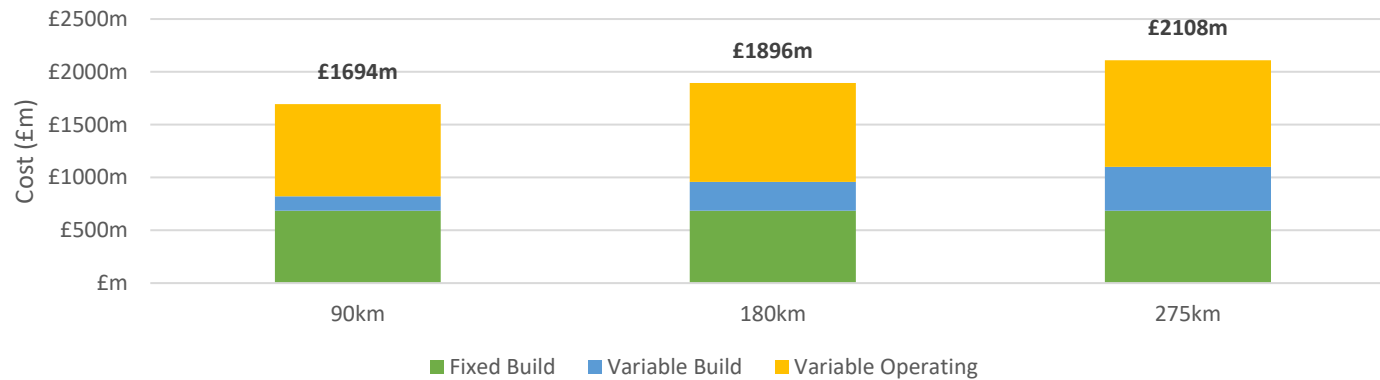

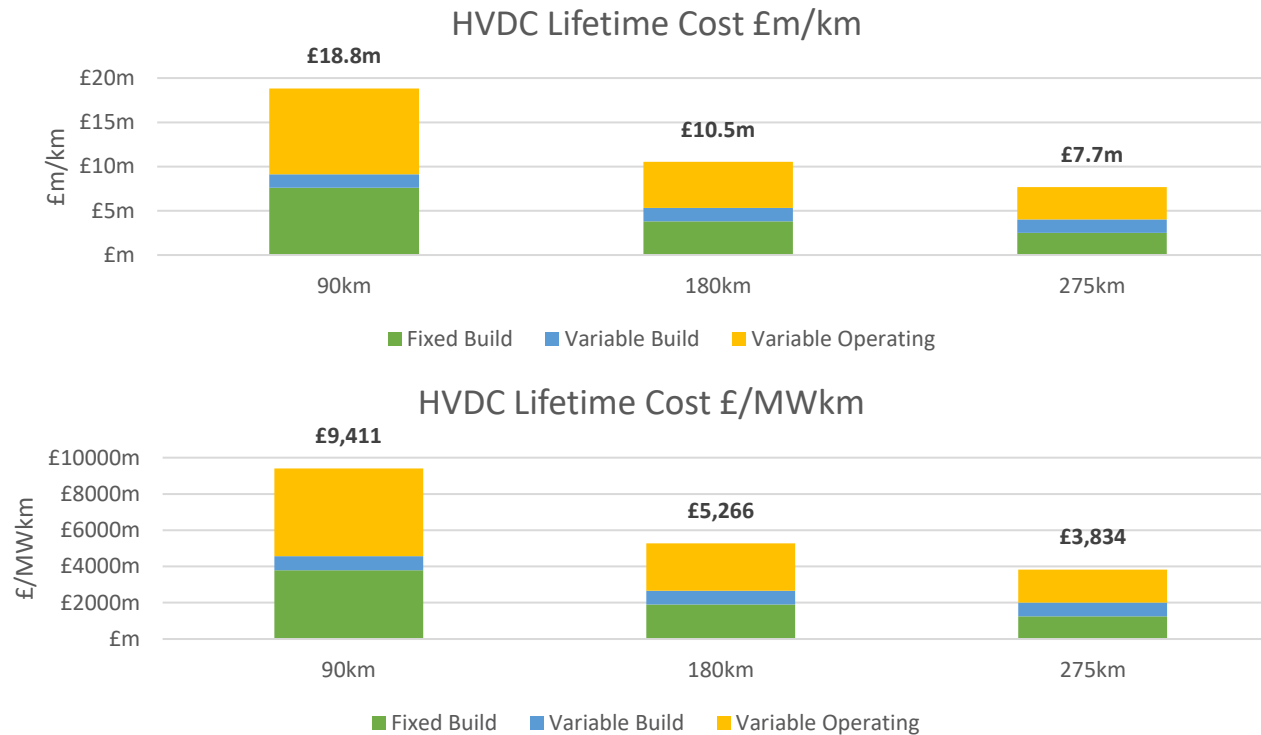

This technology has only been evaluated for a high rating case, meaning that the fixed build component does not change, with the difference being the cable length and losses. Whilst the build cost increases from £821m for 90 km to £1,102m for 275 km, the lifetime cost per km, and lifetime power transfer cost both reduce significantly with length, with a factor of around 0.6 between the medium and short route length, and 0.7 between the long and medium route lengths. Thus, the longer the route length, the better value for money is achieved with this technology. When compared to a HVDC solution with one end located offshore it is possible to see that the magnitude of cost increase due to offshore assets is significant. The build costs for the solution with an offshore platform are around 1.9 to 2.2 times higher, with lifetime costs being around 1.7 to 1.9 times higher. As mentioned in Section C.3.1, there is a limited data-set for 2 GW offshore substations as none have been built yet. As stated in Appendix I, the costs are presented assuming 34% loading as these systems are expected to be used to relieve the onshore transmission system. If the loading is increased to 50% then the lifetime power transfer cost increases by 0.5% (90 km), 1% (180 km) and 1.3% (275km). Should it be increased to 100% then the increase as compared to the 34% case is 3.6% (90 km), 6.4% (180 km) or 8.8% (275 km)

Pressurised Air Cable – 3 km – Rating 4,668 MW

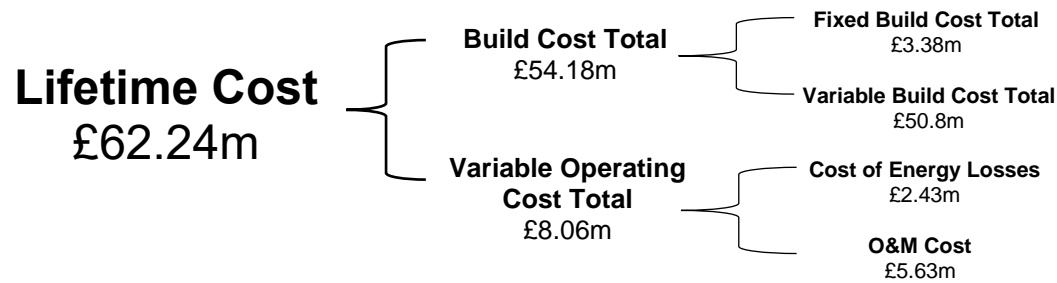

Lifetime Cost per km	£20.75m/km
Lifetime Power Transfer Cost per km	£4,445/MWkm

Data Source: single supplier plus derivation from other technologies – comparatively lower level of cost certainty

Build Costs (£54.18m)

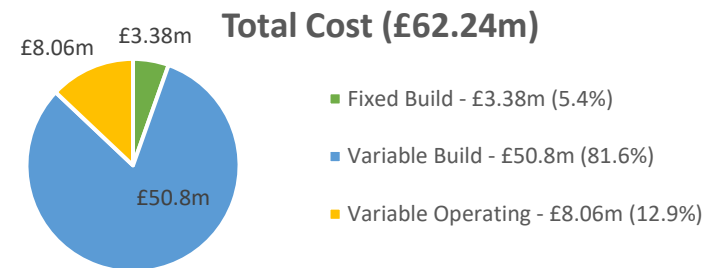
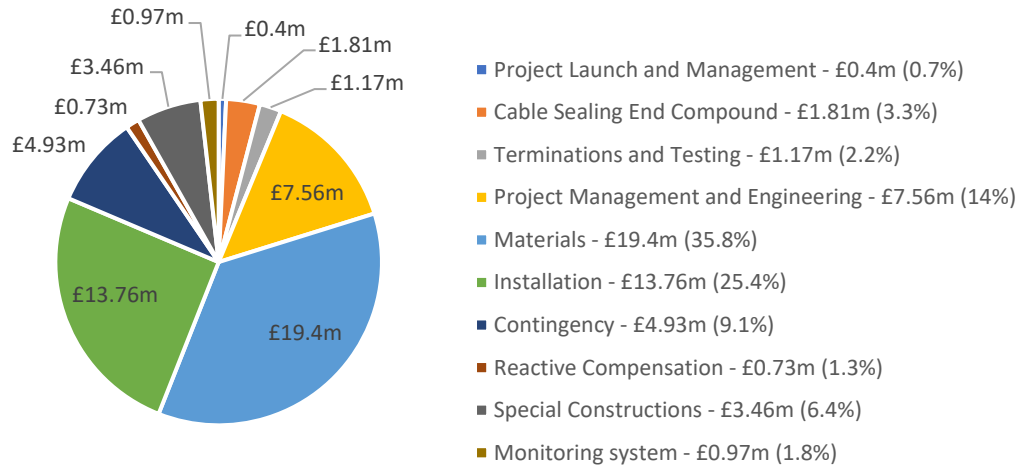

Pressurised Air Cable – 15 km – Rating 4,668 MW

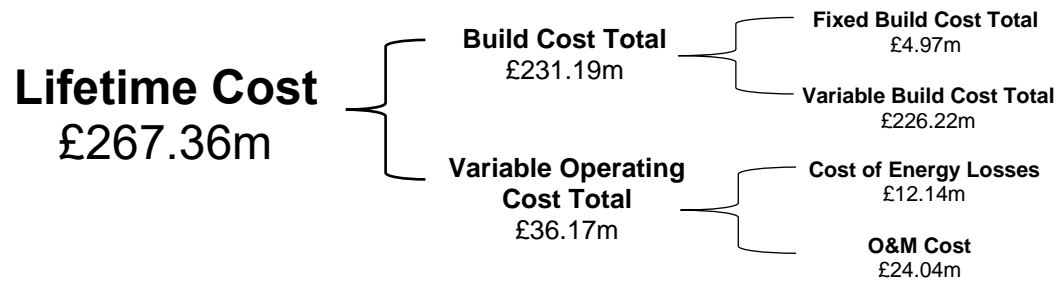

Lifetime Cost per km	£17.82m/km
Lifetime Power Transfer Cost per km	£3,818/MWkm

Data Source: single supplier plus derivation from other technologies – comparatively lower level of cost certainty

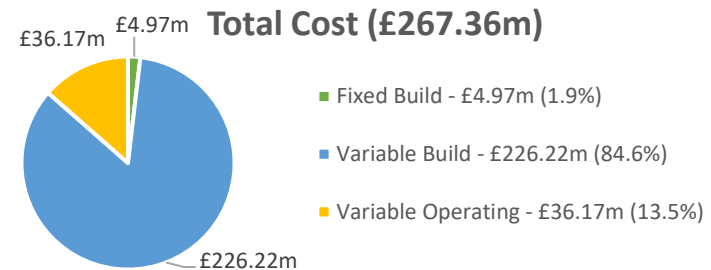
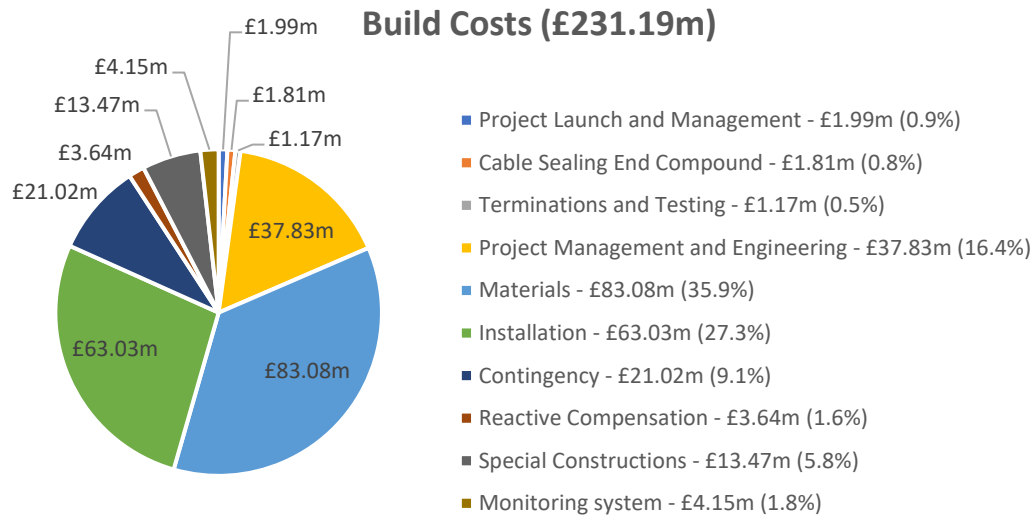

Pressurised Air Cable – 75 km – Rating 4,668 MW

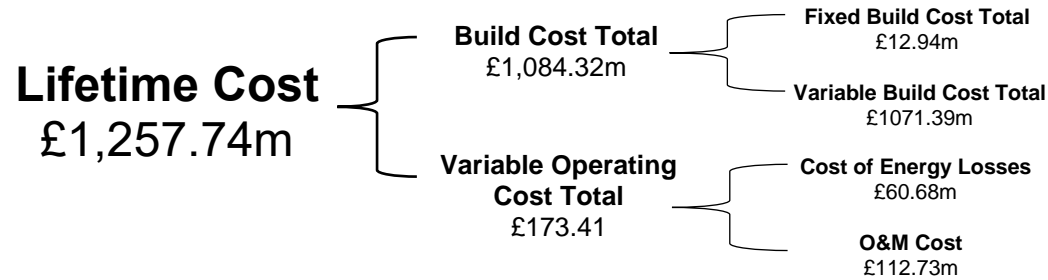

Lifetime Cost per km	£16.77m/km
Lifetime Power Transfer Cost per km	£3,593/MWkm

Data Source: single supplier plus derivation from other technologies – comparatively lower level of cost certainty

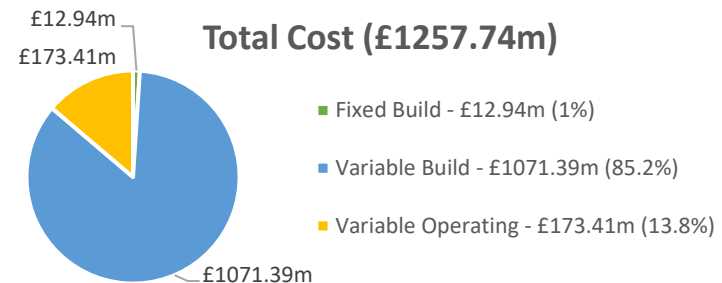
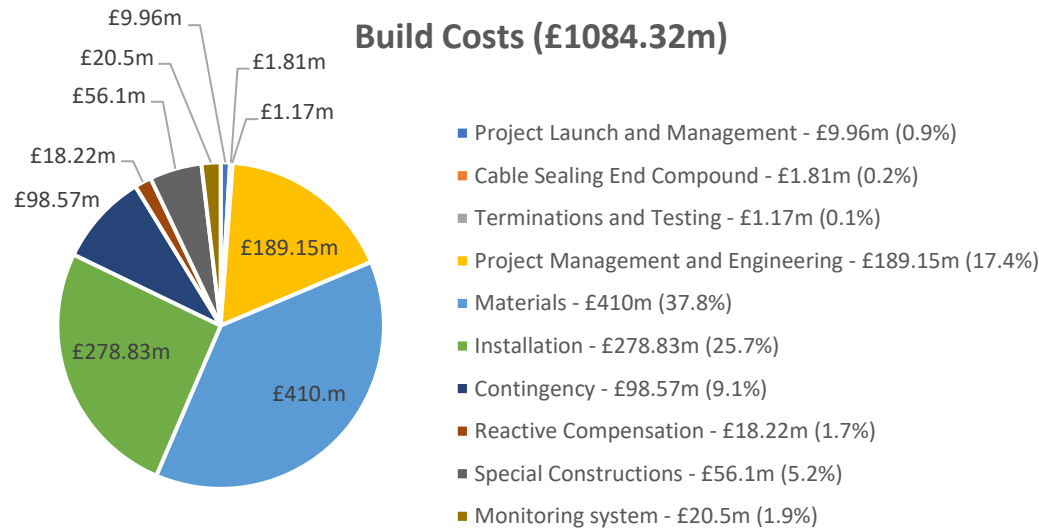

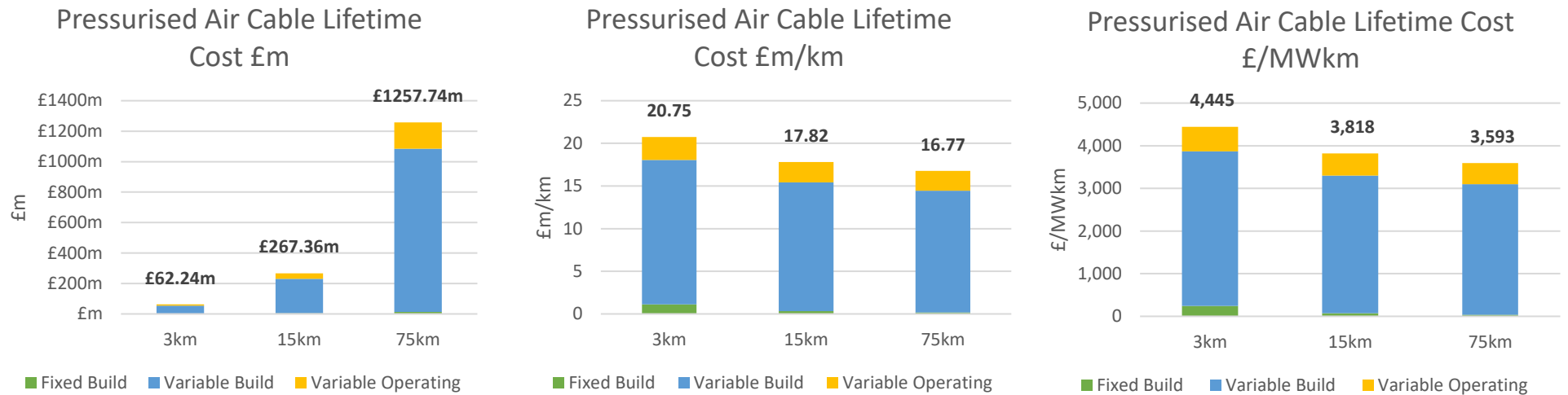

Due to the lack of cost data the level of price certainty is lower for this technology. The manufacturer has supplied data indicating a 5,000 A capacity with ratings up to 300 kV currently available. We have therefore considered a system with a single 5,000 A conductor per phase operating at 275 kV, giving around 2,334 MW of capacity per circuit. This provides a similar power rating to a medium rated 400 kV a.c. cable system, which uses two conductors/phase. When comparing these two technologies, the build cost for the pressurised air cable is expected to be lower as it can be accommodated in a single trench, and is around 0.7 to 0.8 times that of the medium rated cable. This also reflects in the lifetime cost per kilometre which is around 0.7 times that of an a.c. cable, and the lifetime power transfer cost which is around 0.8 times that of an a.c. cable. Given that similar power transfers are being achieved with a single conductor per phase at 275 kV as compared to two conductors per phase at 400 kV, there may be efficiencies as a result of this approach which are not currently recognised in our calculations which could make this an effective solution. For example, this could lead to fewer new substation assets being required. However, the costs in this area should be taken with caution as this technology is not yet fully mature and has not been implemented to date.

Superconducting Cable – 3 km – Rating 2,744 MW

Lifetime Cost
£69.34m

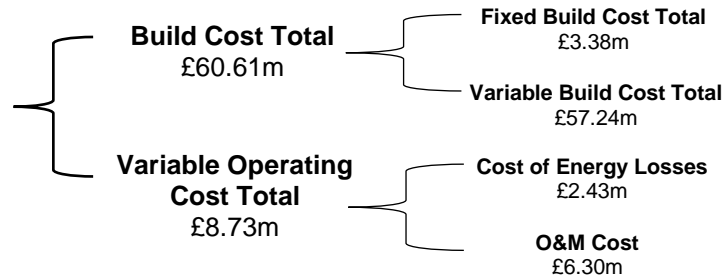

Lifetime Cost per km	£23.11m/km
Lifetime Power Transfer Cost per km	£8,424/MWkm

Data Source: public domain plus derivation from other technologies – comparatively lower level of cost certainty

Build Costs (£60.61m)

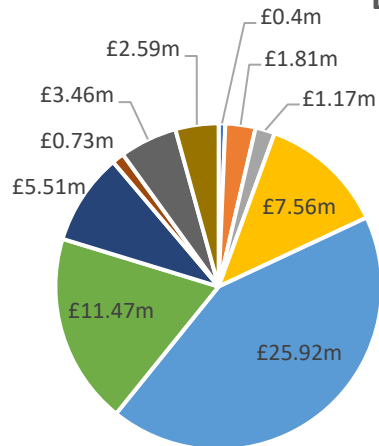

- Project Launch and Management - £0.4m (0.7%)
- Cable Sealing End Compound - £1.81m (3%)
- Terminations and Testing - £1.17m (1.9%)
- Project Management and Engineering - £7.56m (12.5%)
- Materials - £25.92m (42.8%)
- Installation - £11.47m (18.9%)
- Contingency - £5.51m (9.1%)
- Reactive Compensation - £0.73m (1.2%)
- Special Constructions - £3.46m (5.7%)
- Cooling System - £2.59m (4.3%)

Total Cost (£69.34m)

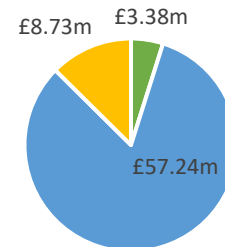

- Fixed Build - £3.38m (4.9%)
- Variable Build - £57.24m (82.5%)
- Variable Operating - £8.73m (12.6%)

Superconducting Cable – 15 km – Rating 2,744 MW

Lifetime Cost
£314.07m

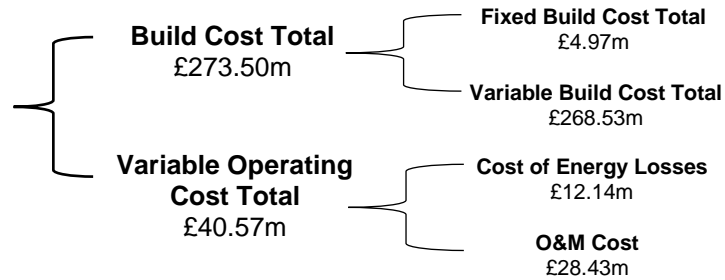

Lifetime Cost per km	£20.94m/km
Lifetime Power Transfer Cost per km	£7,630/MWkm

Data Source: public domain plus derivation from other technologies – comparatively lower level of cost certainty

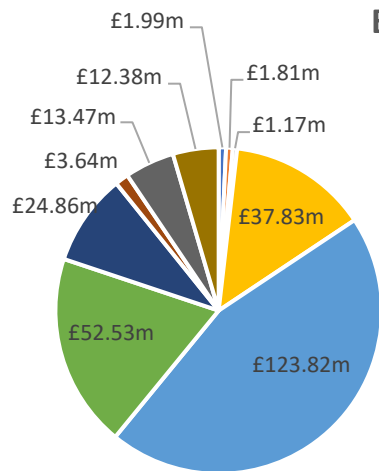

Build Costs (£273.5m)

- Project Launch and Management - £1.99m (0.7%)
- Cable Sealing End Compound - £1.81m (0.7%)
- Terminations and Testing - £1.17m (0.4%)
- Project Management and Engineering - £37.83m (13.8%)
- Materials - £123.82m (45.3%)
- Installation - £52.53m (19.2%)
- Contingency - £24.86m (9.1%)
- Reactive Compensation - £3.64m (1.3%)
- Special Constructions - £13.47m (4.9%)
- Cooling System - £12.38m (4.5%)

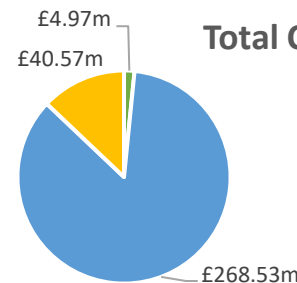

Total Cost (£314.07m)

- Fixed Build - £4.97m (1.6%)
- Variable Build - £268.53m (85.5%)
- Variable Operating - £40.57m (12.9%)

Superconducting Cable – 75 km – Rating 2,744 MW

Lifetime Cost
£1,500.57m

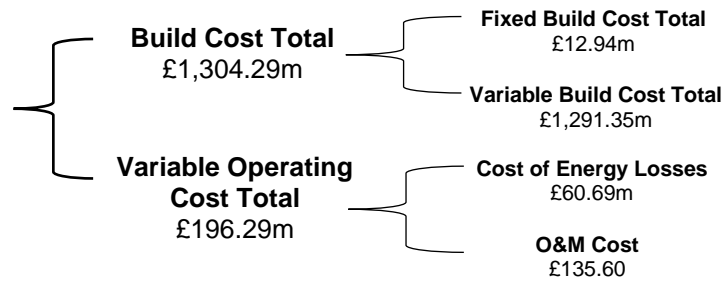

Lifetime Cost per km	£20.01m/km
Lifetime Power Transfer Cost per km	£7,291/MWkm

Data Source: public domain plus derivation from other technologies – comparatively lower level of cost certainty

Build Costs (£1304.29m)

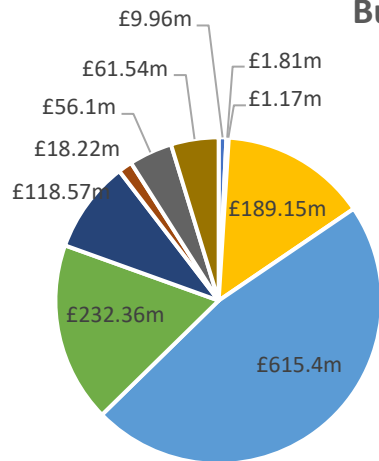

- Project Launch and Management - £9.96m (0.8%)
- Cable Sealing End Compound - £1.81m (0.1%)
- Terminations and Testing - £1.17m (0.1%)
- Project Management and Engineering - £189.15m (14.5%)
- Materials - £615.4m (47.2%)
- Installation - £232.36m (17.8%)
- Contingency - £118.57m (9.1%)
- Reactive Compensation - £18.22m (1.4%)
- Special Constructions - £56.1m (4.3%)
- Cooling System - £61.54m (4.7%)

Total Cost (£1500.57m)

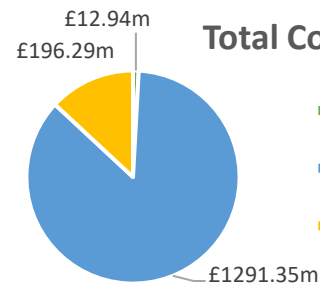

- Fixed Build - £12.94m (0.9%)
- Variable Build - £1291.35m (86.1%)
- Variable Operating - £196.29m (13.1%)

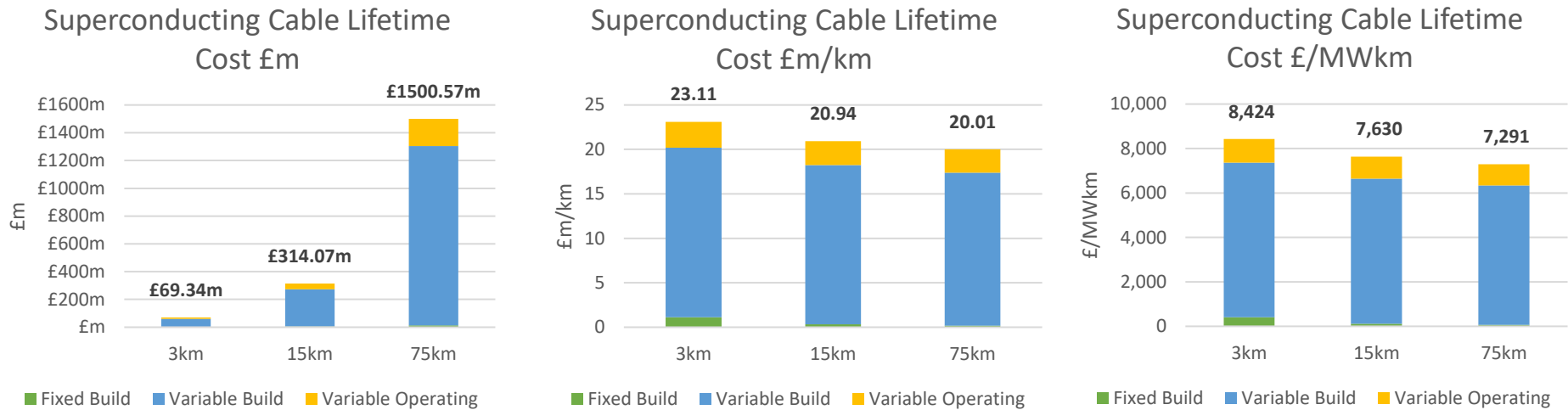

Due to the lack of cost data the level of price certainty is lower for this technology. We have considered a 132 kV system providing around 1,372 MW of capacity per single circuit, similar to a low rated 400 kV underground cable. When comparing these two technologies, the build cost for the superconductor is expected to be higher due to the high cost of the cable system and associated cooling infrastructure. This also reflects in the lifetime cost per kilometre which is around 1.4 times that of an a.c. cable, and the lifetime power transfer cost which is around 1.3 times that of an a.c. cable. Given that similar power transfers are being achieved at 132 kV as compared to 400 kV, there may be efficiencies as a result of this approach which are not currently recognised in our calculations which could make this an effective solution.

Multi-Terminal HVDC – 180 km – Rating 2,000 MW

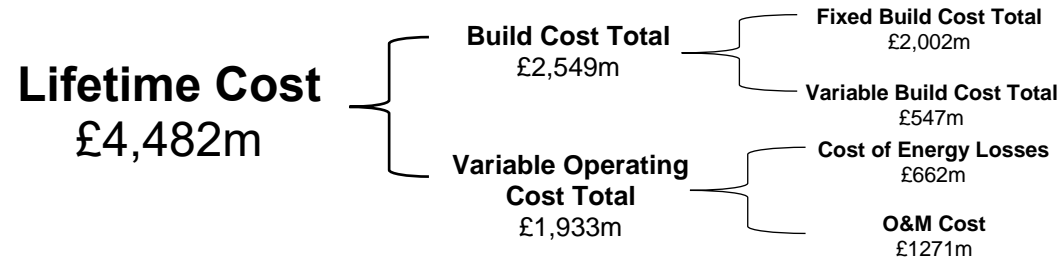

Lifetime Cost per km	£24.90m/km
Lifetime Power Transfer Cost per km	£12,451/MWkm

Data source: indicative estimate based on derivation from public domain information

180km (2000MW) (£4482.4m)

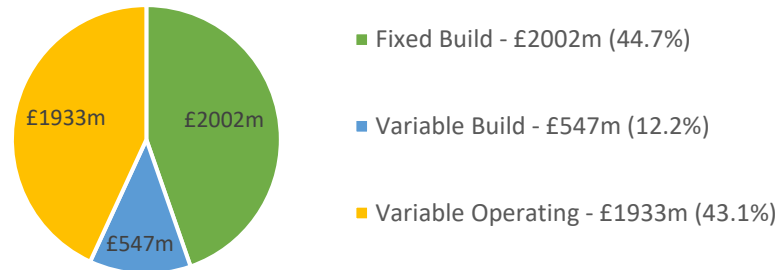

This scenario is based upon an onshore-offshore HVDC link. However, an additional onshore converter station is added and it is assumed that the purpose is to deliver power from an offshore windfarm to two separate onshore locations. Whilst all converter stations are rated for 2 GW, to calculate the losses it is assumed that half the power is delivered to each of the onshore converter stations. The solution is not directly comparable with others. It is noted that the build cost and lifetime cost per km are relatively high due to the construction of the additional infrastructure, but when the power transfer is taken into consideration, the lifetime cost is comparable to that of a medium length, low power point to point link. As for other offshore systems, this calculation is presented with 100% loading. For 50% loading the lifetime power transfer cost reduces to £12,164/MWkm (approximately 2% reduction) and for 34% loading it reduces to £12,113 (approximately 3% reduction)

Reconductoring Using HTLS – 75 km – Additional Capacity of 2,494 MW

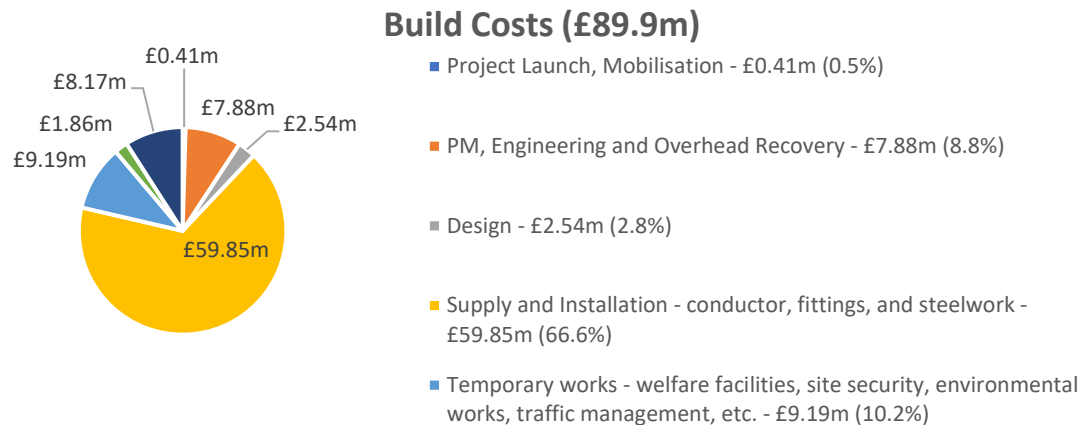
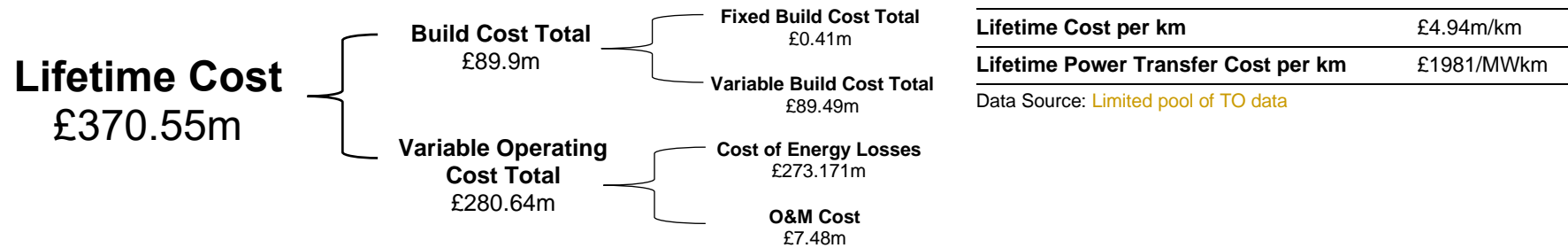

For this case we have assumed a scenario where an overhead line of medium rating is reconducted using high temperature low sag (HTLS) conductor, resulting in a capacity similar to that of a “high” rating. As the towers are re-used and there are minimal costs associated with route planning and similar, the build cost is very low. To calculate the lifetime costs we have only considered the additional capacity which is created, and the associated losses. The lifetime cost of £4.94m/km is of the same order of magnitude as the other 75 km overhead line systems studied, while the lifetime power transfer cost of £1,981/MWkm is slightly higher than that of the other overhead line systems, although still comfortably less than equivalent underground cable circuit.

OHL with T-Pylon Design – 15 km – Medium Rating (4,988 MW)

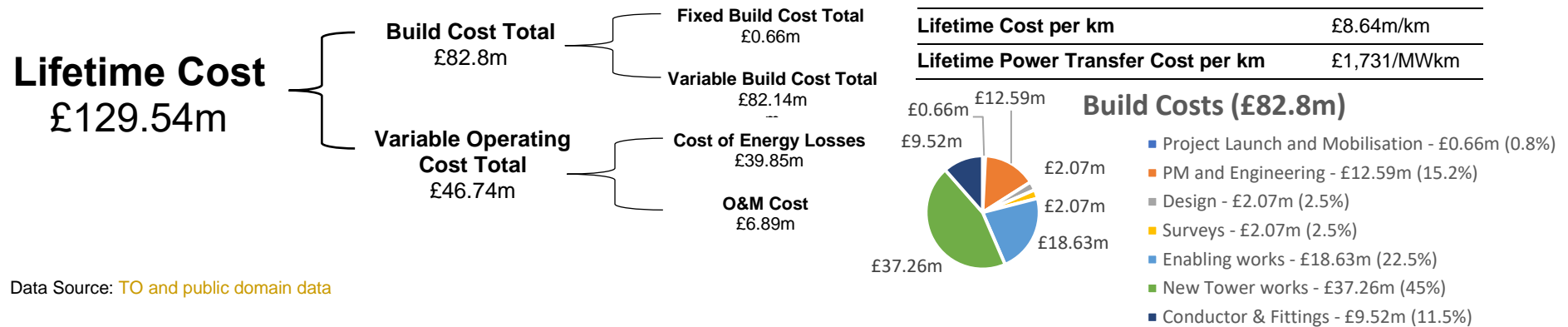

OHL with T-Pylon Design – 75 km – Medium Rating (4,988 MW)

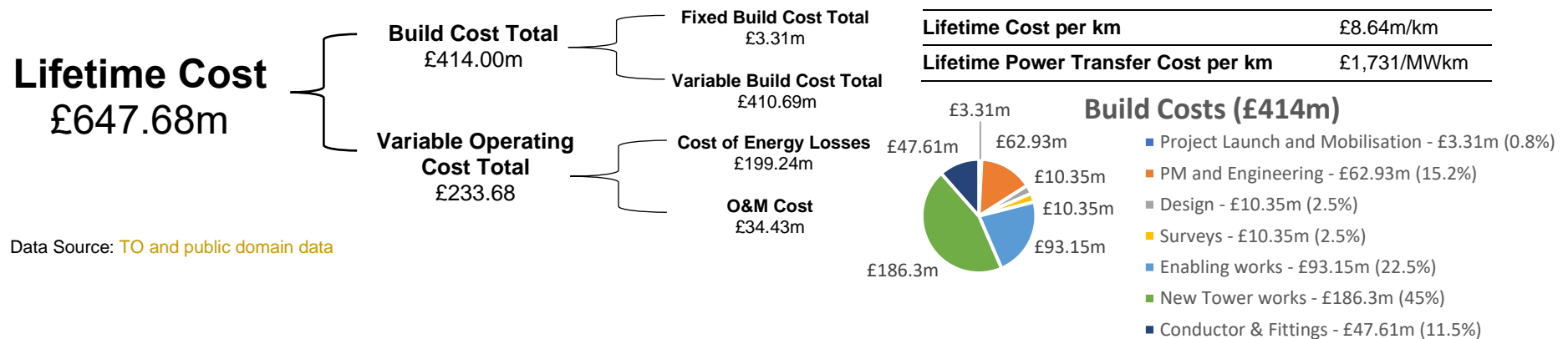

This scenario has been evaluated on the basis of a medium rating solution, as this is what data has been available for. The T-pylons have a greater steel content as compared to conventional towers and this contributes towards a higher build cost, between two and two and half times that of an equivalently rated conventional overhead line. The lifetime costs are also higher, around 1.6 to 1.7 times that of a conventional overhead line, but still significantly less than an equivalent underground cable at around 0.35 to 0.37 times the cost.

Onshore HVDC VSC – 700 km – Rating 2,000 MW

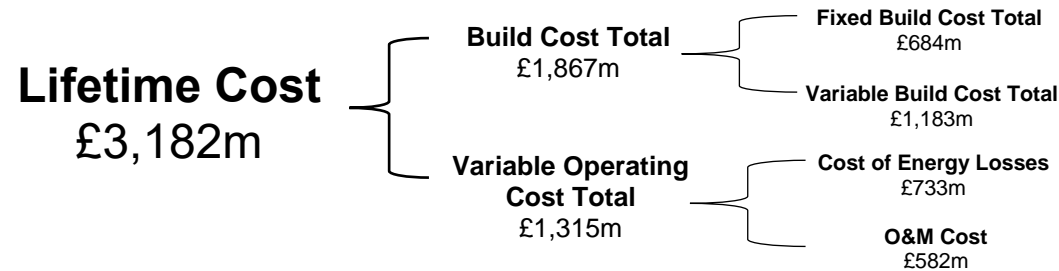

Lifetime Cost per km	£4.55m/km
Lifetime Power Transfer Cost per km	£2,273/MWkm

700km (2GW) (£3182m)

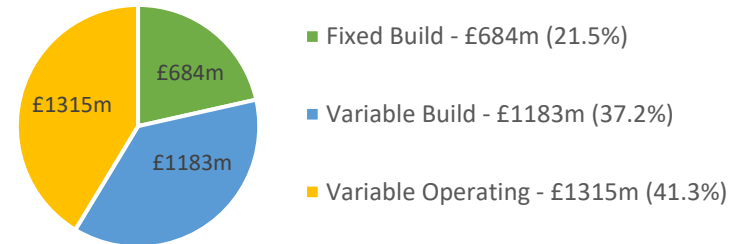

Data Source: derivation from other technologies – comparatively lower level of cost certainty

This scenario uses the same converter station infrastructure as an embedded link, but different costs for HVDC cable as a result of the route being onshore and thus using underground cable as opposed to submarine cable. This case considers a 2 GW onshore HVDC system without metallic return conductor, effectively a single circuit. It is not directly comparable with other technologies studied, although it demonstrates the efficiencies which could be achieved by using HVDC technology for transmitting power over very long distances. Whilst the build cost is high, this is to be expected due to the 700 km length of the circuit. The calculations for onshore a.c. technology are for double circuits, whereas this is effectively a single circuit. However, the lifetime cost of £4.55m/km is significantly lower than the £33.14m to £39.32m per km for a 75 km a.c. underground cable, and only slightly higher than the £3.02m/km for a low rated 75 km overhead line. Considering power transfer capability, the 75 km a.c. cable ranges from £4,429/MWkm to £5,526/MWkm, and the overhead line from £1,210/MWkm to £1,074/MWkm, but it is unlikely that these technologies would be able to deliver the lifetime power transfer cost of £2,273/MWkm over 700 km indicated for the HVDC solution, and they may not be technically feasible over such a distance. However, the cost certainty for the HVDC solution is somewhat less than that of the a.c. solutions, and these conclusions are only valid for the long distance studied, and there is a risk that in practice it may not be possible to secure such a long route in GB. This option is calculated using the onshore loading of 34%. If this is increased to 50% then the lifetime power transfer cost becomes £2,338/MWkm (approximately 3% increase) and for 100% the lifetime power transfer cost becomes £2,696/MWkm (18% increase)

Onshore HVDC LCC – 700 km – Rating 8,000 MW

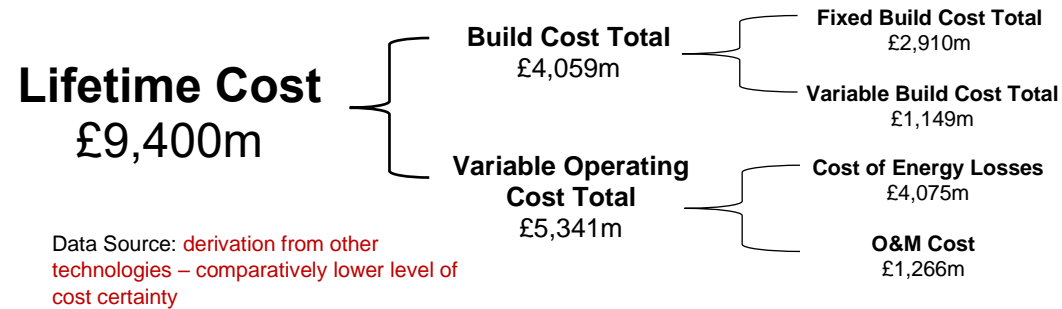

Lifetime Cost per km	£13.43m/km
Lifetime Power Transfer Cost per km	£1,679/MWkm

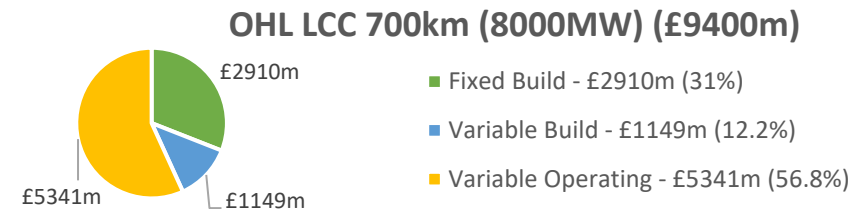

Onshore 765 kV a.c. OHL – 700 km – Rating 8,000 MW

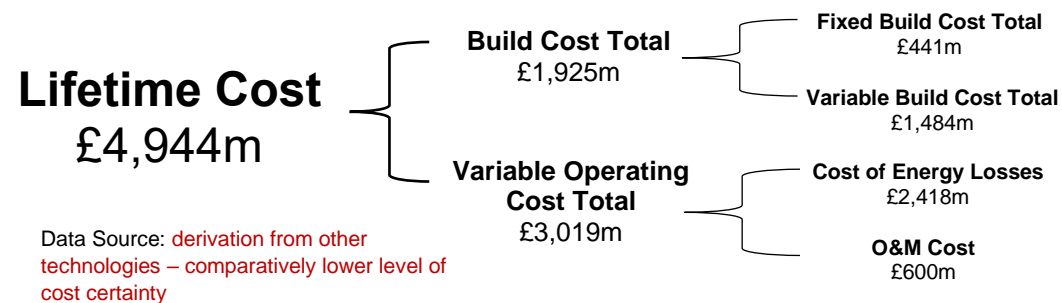

Lifetime Cost per km	£7.06m/km
Lifetime Power Transfer Cost per km	£883/MWkm

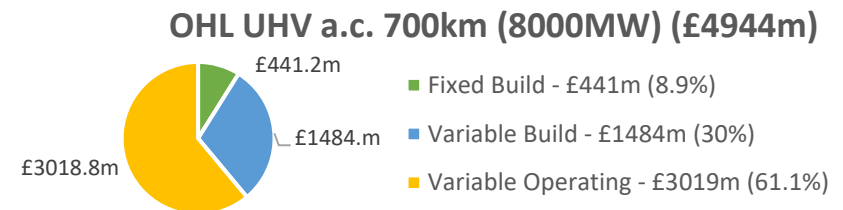

The HVDC scenario considers an overhead line with two phase conductors and a metallic return, providing the functionality for operation at half capacity under certain situations. There is a high build cost due to the long route length and high fixed cost of the converter stations. However, for such a high power transfer, and for such a long route length, the lifetime cost per km and lifetime power transfer costs appear relatively economical. The 765 kV a.c. solution considers only a single circuit, thus if there is a fault then the entire capacity of the circuit is lost. The build cost is not as high as that of the HVDC solution, resulting in lifetime costs which are roughly half that of the HVDC solution. However, if two circuits were constructed to provide redundancy (refer to Section 2.3), which would be more comparable to the HVDC solution, then it is likely that the figures would be comparable.

4.4 Indicative Capital Expenditure Estimates

The following sections present indicative Capital Expenditure (CAPEX) estimates. In general for these categories, the level of data received was minimal and, therefore, only a limited breakdown and an indicative cost-range is provided in tabular format below:

Table 4.2: Indicative CAPEX Estimates

Title	Description	Price-Range	Mott MacDonald Comment
Quadrature Booster	2,750 MVA unit including civil works, switchgear modifications, protection and control modifications.	£35m-£40m	Assumed to be connected to an existing feeder.
Static Series Synchronous Compensator	Based upon a "typical" installation as informed by the data source	£16-£18m	Assumes construction of a small compound to connect into an existing OHL circuit.

4.5 Cost and Ratings Assessment Conclusions

This section presents our conclusions with regards to cost and rating. It should be noted that, when deciding which technology is preferable, the TOs will also consider other factors, some of which are considered in Section 5 of this report. Following the table, a number of charts are provided, giving a visual comparison across the different technologies studied. Section 6 then presents overall conclusions, considering both cost and rating, as well as non-cost factors.

As explained elsewhere, in order to undertake a comparison between different technologies, the costs presented are based on a particular set of assumptions, including items such as the power flows which are expected, circuit design and ratings, and unit cost of energy. The costs are sensitive to variations in these assumptions and information has been presented as to the level of change which may be expected for a range of parameters. Throughout this table, the route length is added in brackets after costs are presented.

4.5.1 Conclusions for Onshore Technologies

Table 4.3: Cost and Ratings Conclusions for Onshore Technologies

Technology	Mott MacDonald Comment
400 kV Overhead Line Data Source: TO and supply chain data	<ul style="list-style-type: none"> This is the most cost-effective technology with a lifetime cost per kilometre of between £3.02m (3 km) and £3.72m (75 km) for a low rating, £5.05m (3 km) and £5.97m (75 km) for a medium rating, and £8.03m (3 km) and £9.02m (75 km) for a high rating. When taking into consideration the amount of power transfer achieved, whilst there is a step-change in cost between a low and medium-rated system, the cost of a medium and high-rated system is similar. This is as a result of the higher cost of losses in the high rated system. For a low-rated system the cost per MWkm is between £1,210 (75 km) and £1,492 (3 km). For medium and high-rated systems, the cost is between £1,196 (medium-rated) and £1,230 (high-rated) for a short route length, £1,073 (medium-rated) and £1,110 (high-rated) for a medium route length, and £1,012 (medium-rated) and £1,074 (high-rated) for a long route length. The ratings considered take into consideration a circuit which also includes an element of underground cable. Should a "pure" overhead line route be achievable, then improvements to the lifetime costs would be seen as compared to the above figures.
400 kV Underground Cable Data Source: TO and supply chain data	<ul style="list-style-type: none"> The lifetime cost per kilometre of UGC is between £13.97m (75 km) and £16.71m (3 km) for a low rating, £28.08m (3 km) and £23.61m (75 km) for a medium rating, and £39.32m (3 km) and £33.14m (75 km) for a high rating. When taking into consideration the amount of power transfer achieved, there is a gradual reduction in costs between low, medium and high ratings, and also by short, medium and long route lengths.

Technology	Mott MacDonald Comment
400 kV cable in tunnel Data Source: TO and public domain data	<ul style="list-style-type: none"> For a low-rated system, the cost per MWkm is between £6,700 (3 km) and £5,601 (75 km); for a medium-rated system the cost is between £5,629 (3 km) and £4,733 (75 km), and for a high-rated system the cost is between £5,255 (3 km) and £4,429 (75 km). Overall, the lifetime cost of an underground cable system is between four and five times that of an equivalently-rated overhead line system. Considering purely build cost, for a low circuit rating the cost of the underground cable system is around six times that of an overhead line. However, for medium and high-rating cases, the build cost of an underground cable system is between eight and ten times that of an overhead line system, as a result of having to install multiple conductors per phase.
Pressurised Air Cable Data Source: single supplier plus derivation from other technologies – comparatively lower level of cost certainty	<ul style="list-style-type: none"> For a low-rated cable system, a 3 m diameter tunnel is used, whereas a 4 m diameter is used for a medium and high-rated tunnel. This reflects in the cost per kilometre, which is between £61.5m (3 km) and £41.59m (75 km) for a low-rated system, between £79.49m (3 km) and £57.92m (75 km) for the medium-rated system, and £82.56m (3 km) and £60.94m (75 km) for the high-rated systems. As a high-rated cable system can be achieved whilst still using two conductors per phase, the difference between a high and medium-rated system is not large. For a low-rated system, the cost per MWkm is between £24,658 (3 km) and £16,674 (75 km); for a medium-rated system the cost is between £15,936 (3 km) and £11,612 (75 km), and for a high-rated system the cost is between £11,034 (3 km) and £8,145 (75 km). Overall, the lifetime cost of a cable in a tunnel is two to three times that of an underground cable system. However, considering purely build costs, a cable in a tunnel is between two and four times that of a direct buried cable.
Superconducting Cable Data Source: public domain plus derivation from other technologies – comparatively lower level of cost certainty	<ul style="list-style-type: none"> Due to a lack of data, there is a low level of cost certainty associated with this technology. The case evaluated is for a 275 kV system at a single rating, which can be considered similar to a “medium” rating UGC. This level of power transfer can be achieved by using a single conductor per phase, accommodated in a single trench, resulting in a lower build cost as compared to the medium rated a.c. cable. The lifetime cost per kilometre reduces by length from £20.75m for the short route length, to £16.77m for the long route length. As a result of the lower build cost, the lifetime power transfer cost is less than that of a similarly rated underground cable. Given that similar power transfers are being achieved with a single conductor per phase at 275 kV, as compared to two conductors per phase at 400 kV, there may be efficiencies as a result of this approach which are not currently recognised in our calculations. This could make this an effective solution, due to factors such as a lower quantity of associated infrastructure being required (e.g., substations, transformers, switchgear).
Reconductoring using HTLS Data Source: Limited pool of TO data	<ul style="list-style-type: none"> Due to a lack of data, there is a low level of cost certainty associated with this technology. We have considered a 132 kV system providing around 1,372 MW of capacity per single circuit, similar to a low rated 400 kV underground cable. Build cost for the superconductor is expected to be higher due to the high cost of the cable system and associated cooling infrastructure. The lifetime cost per kilometre of the superconducting cable is around 1.2 to 1.4 times that of an a.c. cable, and the lifetime power transfer cost is around 1.3 times that of an a.c. cable. Given that similar power transfers are being achieved at 132 kV, as compared to 400 kV, there may be efficiencies as a result of this approach which are not currently recognised in our calculations. This could make this an effective solution, due to factors such as a lower quantity of associated infrastructure being required (e.g., substations, transformers, switchgear).
Reconductoring using HTLS Data Source: Limited pool of TO data	<ul style="list-style-type: none"> Only a limited pool of TO data was available for this technology. The scenario considered is for reconductoring an existing medium-construction overhead line with HTLS, resulting in a capacity similar to that of a “high” rating. Due to re-use of existing infrastructure, the build cost is very low. The lifetime costs only considered the additional capacity which is created and the associated losses. The lifetime cost of £4.94m/km is of the same order of magnitude as the other 75 km overhead line systems studied, while the lifetime power transfer cost of £1,981/MWkm is

Technology	Mott MacDonald Comment
Use of alternative tower technologies (t-pylons) Data Source: TO and public domain data	slightly higher than that of the other overhead line systems, although still comfortably less than equivalent underground cable circuit. <ul style="list-style-type: none"> This is evaluated on the basis of a medium-construction solution and medium route length, as this is what data has been available for. Build cost is approximately 2 to 2.5 times that of an equivalently-rated conventional overhead line. The lifetime costs are around 1.6 to 1.7 times that of a conventional overhead line. It is still significantly less than an equivalent underground cable, at around 0.35 to 0.37 times the cost.
Onshore HVDC VSC (2 GW, 700 km) Data Source: derivation from other technologies – comparatively lower level of cost certainty	<ul style="list-style-type: none"> This case considers a 2 GW onshore HVDC system without metallic return conductor, effectively a single circuit. It is not directly comparable with other technologies studied. There is a high build cost but this is to be expected due to the long circuit length. The lifetime cost of £4.55m/km is significantly lower than those seen for a.c. cable systems over shorter distances, but slightly higher than those seen for a.c. overhead lines over shorter distances. The lifetime power transfer cost of £2,273/MWkm appears to be relatively economical. The 75 km a.c. cable ranges from £4,429/MWkm to £5,601/MWkm, and the overhead line from £1,210/MWkm to £1,074/MWkm, but it is unlikely that these technologies operating at 400 kV would be able to achieve values close to those of the HVDC system over this distance, and they may not be technically feasible.
Onshore HVDC LCC (8 GW, 700 km) Data Source: derivation from other technologies – comparatively lower level of cost certainty	<ul style="list-style-type: none"> Due to a lack of data, there is a low level of cost certainty associated with this technology. This scenario considers an overhead line with two phase conductors and a metallic return, providing the functionality for operation at half capacity under certain situations. Build cost is high due to the long route length and high fixed cost of the converter stations. Lifetime cost per kilometre (£13.43m) and lifetime power transfer costs (£1,679) are relatively economical. Costs associated with diversion of existing circuits into converter stations, or wider system impacts, are not considered, as they are difficult to quantify and highly project specific. However, they could be significant and would need to be taken into account when assessing the viability of such a project.
UHV a.c. transmission (8 GW, 700 km) Data Source: derivation from other technologies – comparatively lower level of cost certainty	<ul style="list-style-type: none"> Due to a lack of data, there is a low level of cost certainty associated with this technology. This solution considers only a single circuit, so if there is a fault then the entire capacity of the circuit is lost. Build cost is not as high as that of the HVDC solution, resulting in lifetime costs of £7.06m/km and £883/MWkm, which are roughly half that of the HVDC solution. However, if two circuits were constructed to provide redundancy, then it is likely that the figures would be comparable. Costs associated with diversion of existing circuits into the substation, or wider system impacts, are not considered, as they are difficult to quantify and highly project specific. However, they could be significant and would need to be taken into account when assessing the viability of such a project.

Considering the technologies which could be used to increase the use of existing thermal capacity, whilst a lifetime cost assessment cannot be carried out, the indicative CAPEX estimate shows that a quadrature booster is likely to be twice the cost of a static series synchronous compensator.

As in the previous cost study, we have identified significant variations in the lifetime cost of the transmission technologies considered. The average costs of onshore technologies over the range of ratings and transmission lengths considered are summarised in Table 4.4. A more detailed analysis of costs over typical circuit lengths (i.e., excluding the 700 km options) is shown in Figure 4.2.

Table 4.4: Onshore Technology £/MWkm Comparison

Technology	Average £/MWkm
400 kV a.c. Overhead Line	£1,186
400 kV a.c. Underground Cable	£5,333
400 kV a.c. Cable in Tunnel	£14,104
275 kV a.c. Pressurised Air Cable (2.3 GW)	£3,952
132 kV a.c. Superconducting Cable (1.4 GW)	£7,782
Reconductoring using HTLS a.c. conductor (75 km only)	£1,981
Use of alternative a.c. tower technologies (15 km and 75 km, 4,988 MW double circuit rating)	£1,731
Onshore HVDC VSC (2 GW, 700 km, single circuit)	£2,273
Onshore HVDC LCC (8 GW, 700 km, single circuit)	£1,679
UHV onshore a.c. transmission (8 GW, 700 km, single circuit)	£883

Scoring Key

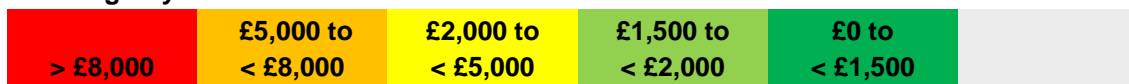
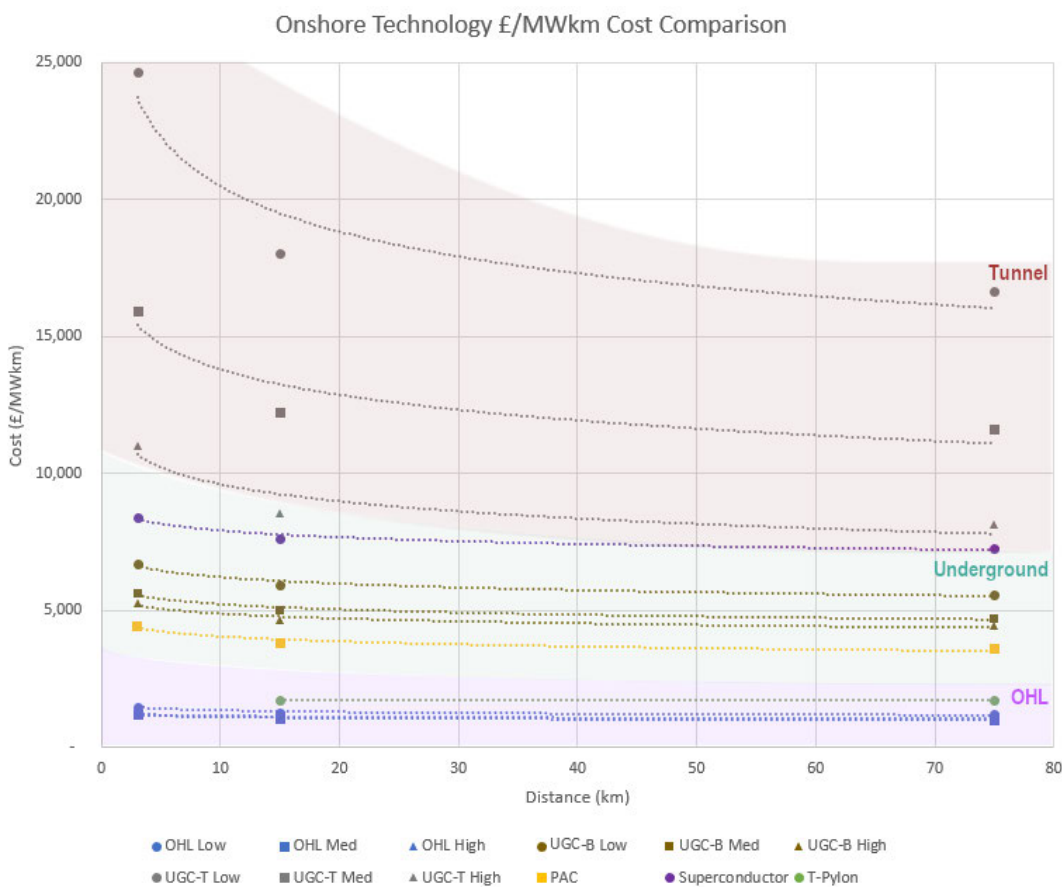

Figure 4.2: Onshore Technology £/MWkm Cost Comparison



It can be concluded from this data that there is a clear differentiation at 400 kV between the costs of overhead lines and buried underground cables, and that cables in tunnels involve a very significant cost premium. It should additionally be noted that these are lifetime costs, considering operational power losses in addition to build costs. Consequently, since losses in cable systems are lower than those in overhead lines, the differential in build costs is greater.

The data presented in Table 4.4 suggests that the long (700 km) high-power technologies would be cost effective in comparison with conventional overhead lines. However, it must be recognised that these options provide limited redundancy and that post-fault operating conditions may constrain their effective utilisation. Furthermore, extensive reconfiguration of the existing network would be required to route 8GW through a single circuit and the costs, and environmental impacts, of these additional works has not been considered in this report. It is also likely that construction of continuous routes of this length would face significant challenges for a number of reasons including from a planning perspective, obtaining the necessary land ownership rights, and avoiding obstacles such as urban areas and existing infrastructure. It is therefore not considered as a realistic technology for deployment within the GB network in the medium term.

The figures in the following pages present a comparison of the different technologies in the form of bar charts using the following abbreviations:

- OHL: Overhead Line
- UGC-B: Underground Cable – Buried
- UGC- T: Underground Cable – in tunnel

Figure 4.3: Onshore Technologies – 3 km Comparison

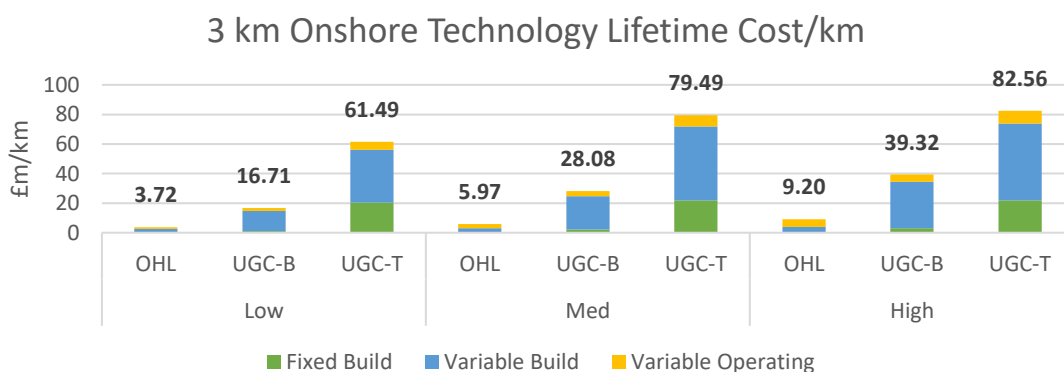
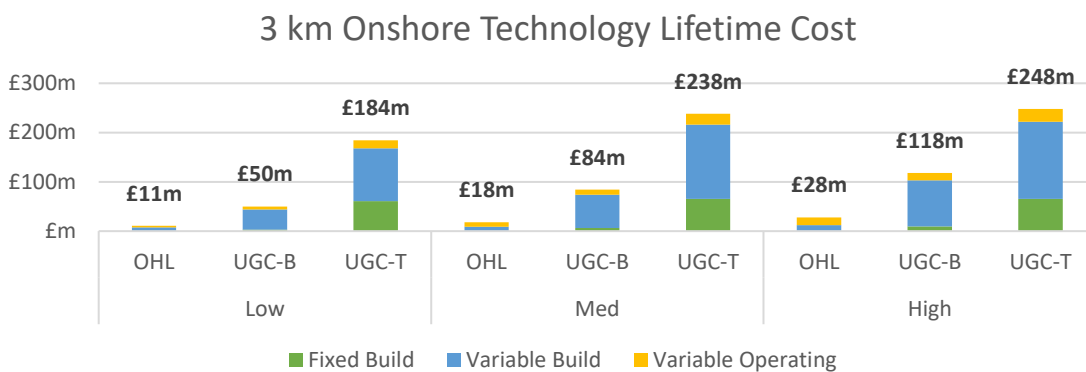

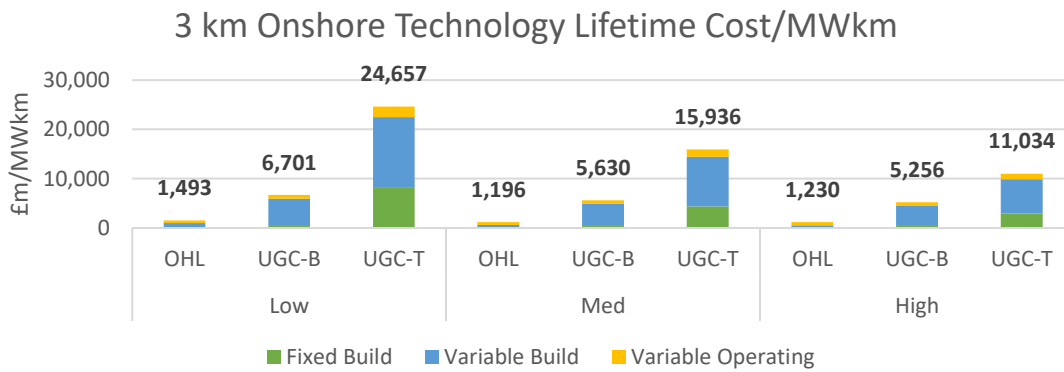
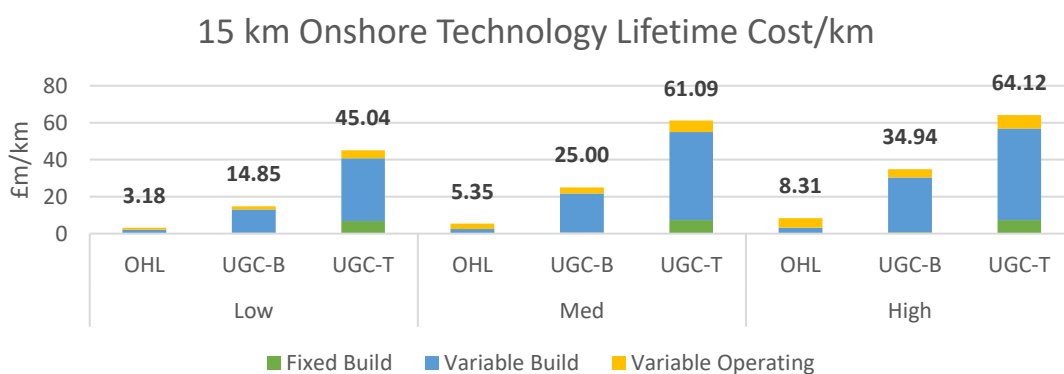
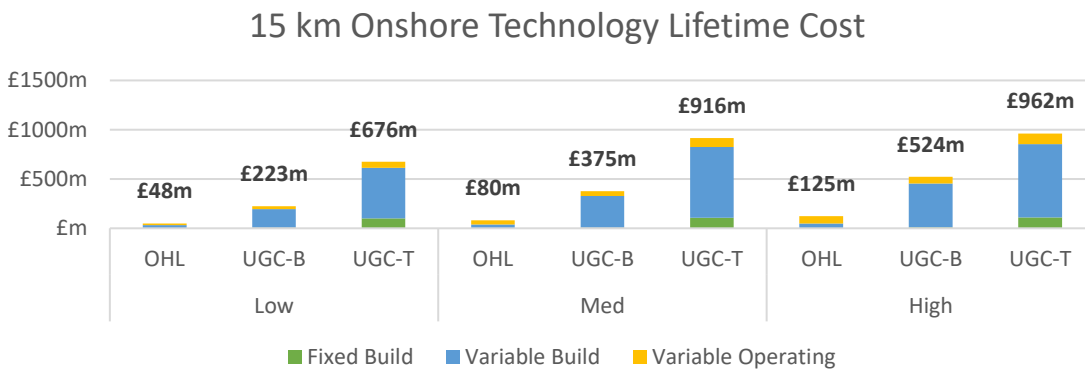

Figure 4.4: Onshore Technologies – 15 km Comparison



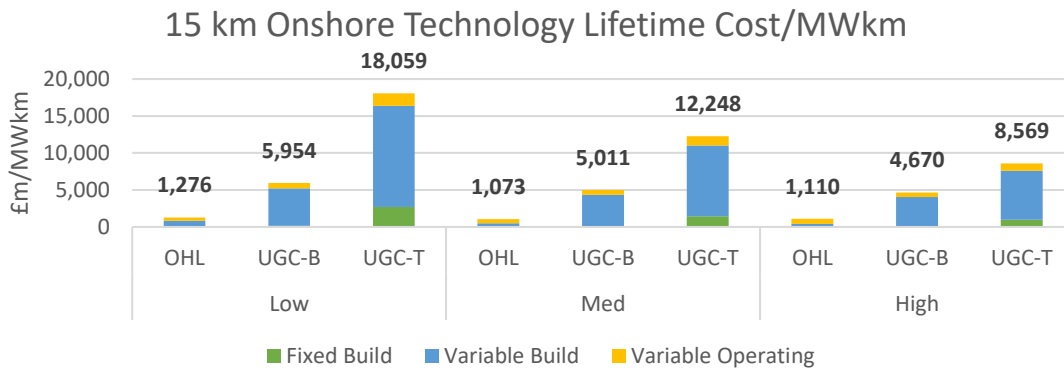
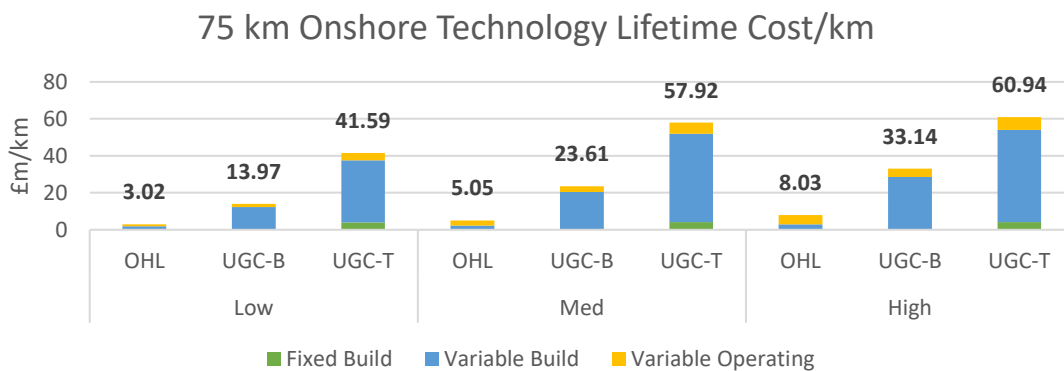
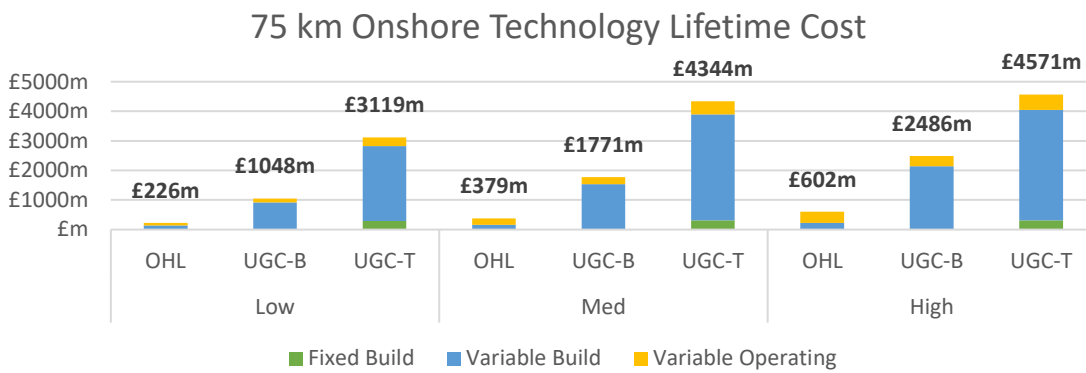

Figure 4.5: Onshore Technologies – 75 km Comparison



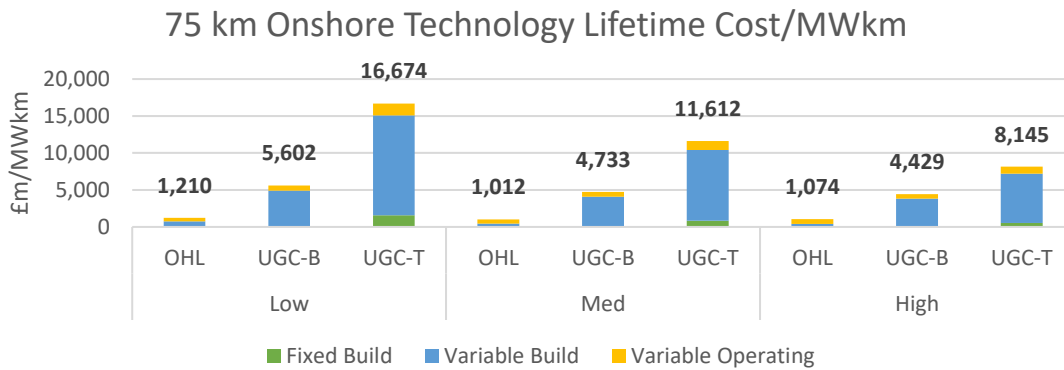
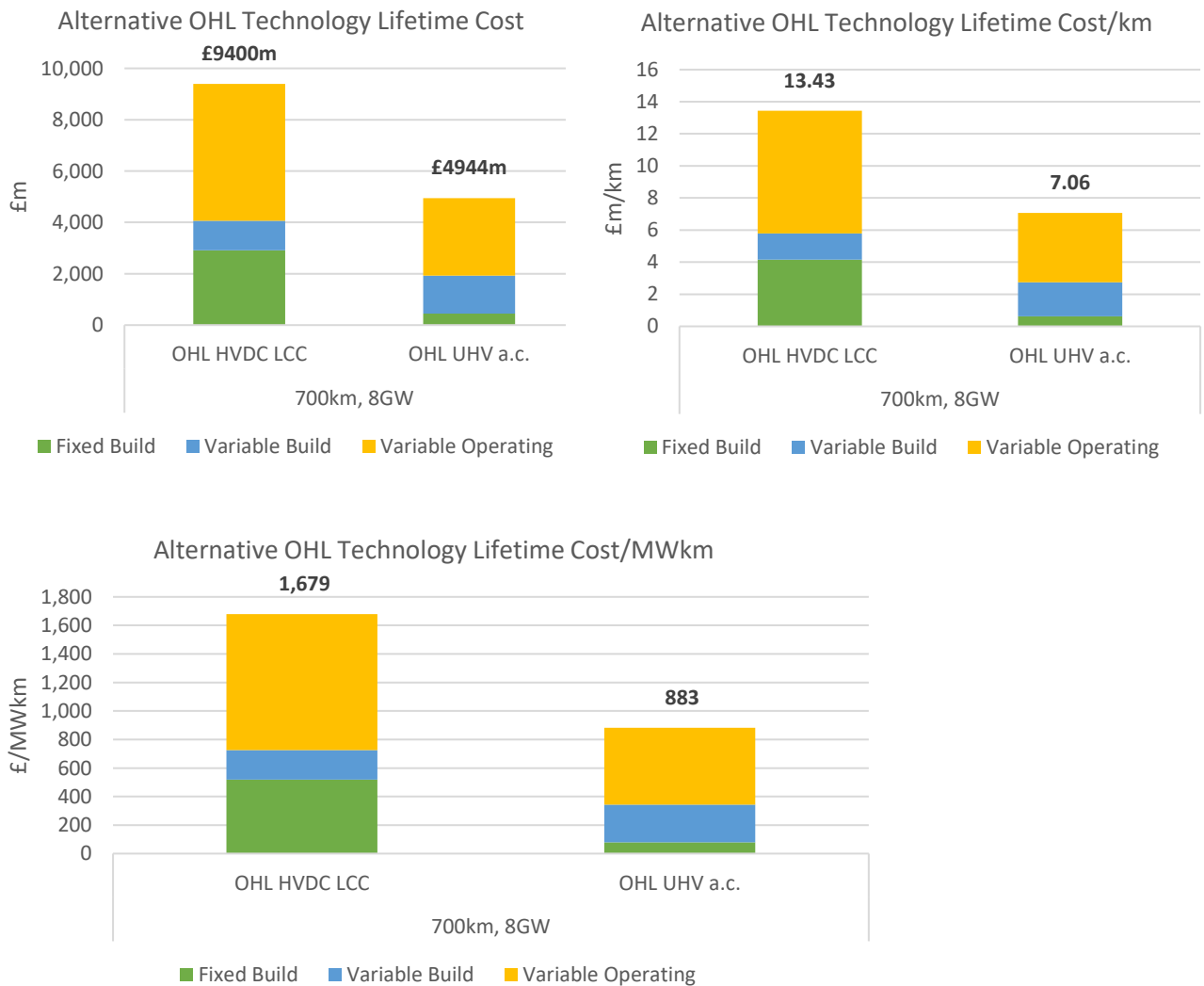

Figure 4.6: Alternative OHL Technologies 700 km, 8,000 MW Comparison



4.5.2 Conclusions for Offshore Technologies

Table 4.5: Cost and Ratings Assessment Conclusions for Offshore Technologies

Technology	Mott MacDonald Comment
275 kV a.c. submarine cable Data Source: public domain data	<ul style="list-style-type: none"> The lifetime cost for this technology is between £6.45m (3 km) and £4.6m (75 km) per kilometre for a low-rated solution; £14.04m (3 km) and £9.05m (75 km) for a medium-rated solution; and £29.56m (3 km) and £18.58m (75 km) for a high-rated solution. When taking into consideration the amount of power transferred, for short route lengths, the higher the rating, the higher the cost per MWkm. This is as a result of the capital cost of the connection infrastructure. However, for medium and long route lengths the lifetime cost per MW km for a given distance is similar, irrespective of the rating. This is because considering the combination of distance and power transfer level, the build costs and operating costs even themselves out. For a 90 km route length, the cost per MWkm is between £12,891 (low rating) and £14,779 (high rating). For a 180 km route length, it is between £10,212 (low rating) and £10,750 (high rating), and for a 275 km route length, it is between £9,046 (medium rating) and £9,289 (high rating), with the medium rating being most cost-effective.
HVDC VSC – onshore-offshore Data Source: public domain data	<ul style="list-style-type: none"> The lifetime cost for this technology is between £10.33m (3 km) and £4.64m (75 km) per kilometre for a low-rated solution; £19.32m (3 km) and £8.02m (75 km) for a medium-rated solution; and £36.5m (3 km) and £13.99m (75 km) for a high-rated solution. When taking into consideration the amount of power transferred, the higher the power, the lower the cost in £/MWkm terms. Similarly, the longer the route length the lower the cost in £/MWkm. Therefore, a high power transfer over a long route length is the most economical over the lifetime of the asset. For a 90 km route length, the cost per MWkm is between £20,662 (low rating) and £18,252 (high rating). For a 180 km route length, it is between £12,204 (low rating) and £9,877 (high rating), and for a 275 km route length, it is between £9,282 (low rating) and £6,997 (high rating). In terms of build cost, for a short route length, with low or medium power transfer the costs are higher than that for an a.c. solution, but for a short route length with high power transfer requirements, the build cost is likely to be similar. For a medium route length, the build cost for both technologies is likely to be comparable for a low rated solution, but a HVDC solution would be lower-cost for a medium or high rating. For long route lengths, the build cost is lower for HVDC in all instances, with this being most pronounced for a high power requirement, where the cost is around 0.7 times that for an a.c. solution. This is also indicated in Figure C.5, which illustrates that, for a high-rated solution, the break-even distance is around 100 km, for a medium-rated solution it is around 140 km, and for a low-rated solution it is around 240 km. In terms of lifetime cost in £/MWkm, the breakeven distance is extended slightly as compared to when only the build cost is considered. For the short route length, the a.c. solution is more cost effective in all instances, which is also the case for the medium route length at low rating. This is as a result of the high upfront cost of converter stations. For the medium route length, at medium rating, and long route length at low rating, the costs are comparable, and in all other instances the HVDC solution is more cost effective. This is as a result of a greater quantity of cables being required for the a.c. solution. This is most pronounced in the high rating, long route length where the HVDC solution is around 0.75 that of the a.c. solution. This is shown graphically in Figure 4.7, which suggests that for a high rating the break-even distance is around 150 km, for a medium rating it is around 180 km, and for the low rating it is around 275 km.
HVDC embedded link – onshore-onshore Data Source: public domain data	<ul style="list-style-type: none"> This technology has only been evaluated for a high rating case, and the lifetime cost is indicated as £18.82m/km for 90 km, £10.53m/km for 180 km and £7.67m/km for 275 km. When taking into consideration the amount of power transferred, the costs are £9,411/MWkm for 90 km, £5,266/MWkm for 180 km and £3,834/MWkm for 275 km. Thus, the longer the route length, the more value for money is achieved. This scenario cannot be directly compared with others. However, it can be used to assess the magnitude of cost increases for locating equipment offshore. As compared to a solution of same rating and length, but with one converter station located offshore, the build costs for that (i.e. the offshore-onshore case) are between 1.9 and 2.2 higher, with lifetime costs being around 1.7 to 1.9 times higher.

Technology	Mott MacDonald Comment
Multi-terminal HVDC Data source: indicative estimate based on derivation from public domain information	<ul style="list-style-type: none"> Due to a lack of data, there is a low level of cost certainty associated with this technology. This technology cannot be directly compared with other scenarios. However, considering a system with three 2 GW converter stations, one of which is located offshore, and two 180 km cable circuits, the lifetime cost per kilometre is indicated as £24.90m, and the lifetime power transfer cost is indicated as £12,541/MWkm. Whilst this provides the greatest system flexibility, it could be considered to only construct 1GW converter stations onshore, resulting in an improvement in the above figures. Whilst this solution is more expensive than a single point to point link, it is more cost effective than constructing two separate point to point links. Multi-terminal solutions are likely to be cost-effective in the event that multiple sources of generation are to be connected.

The figures in the following pages present a comparison of the different technologies in the form of bar charts.

Figure 4.7: Lifetime Cost of HVDC and a.c. solutions in £/MWkm

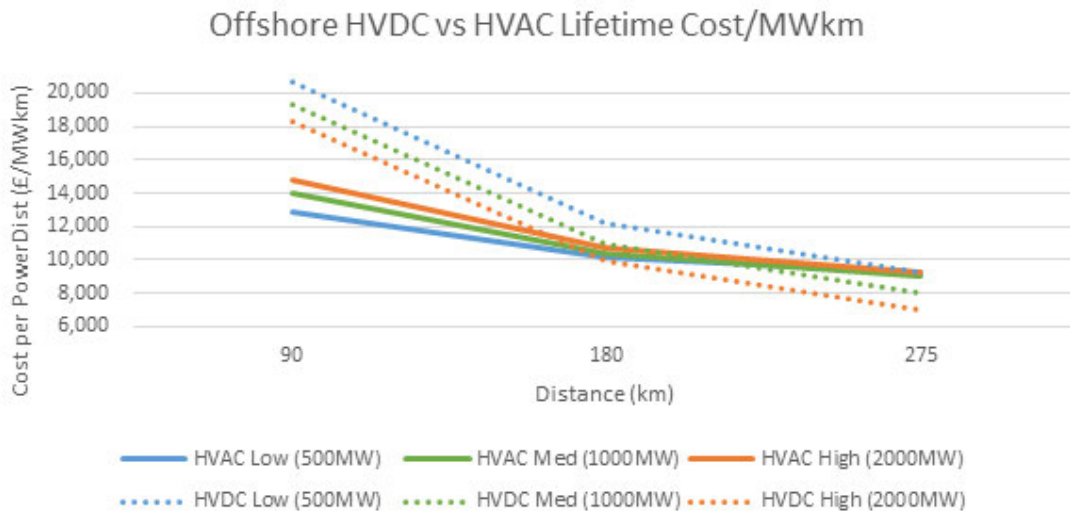
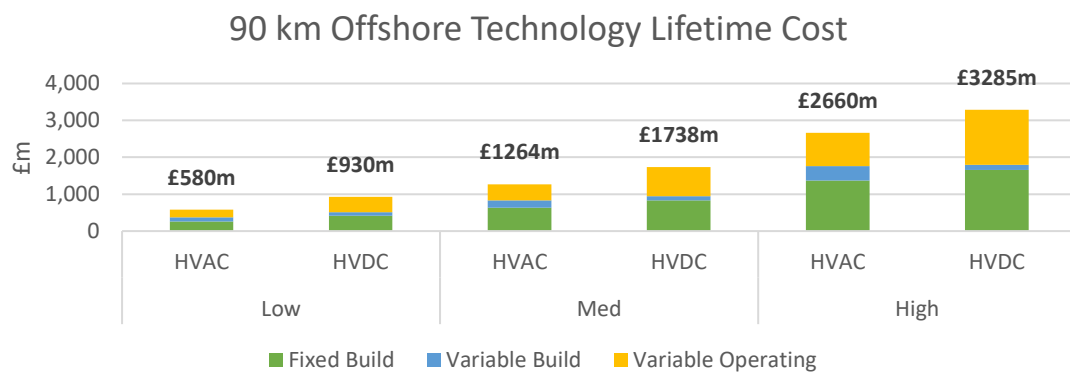
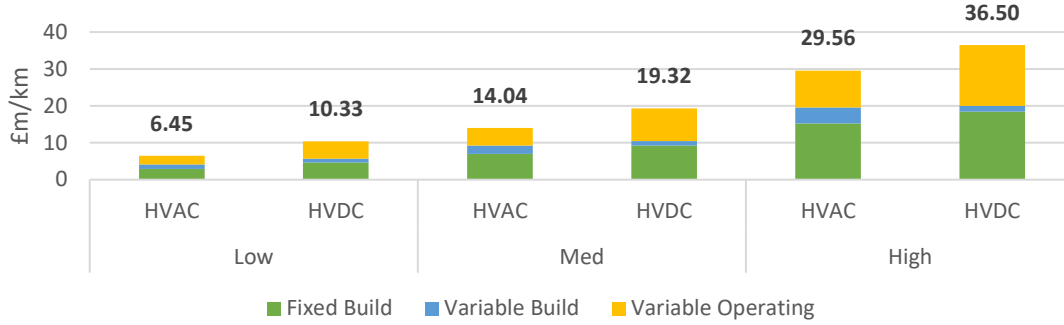

Figure 4.8: Offshore Technologies – 90 km Comparison



90 km Offshore Technology Lifetime Cost/km



90 km Offshore Technology Lifetime Cost/MWkm

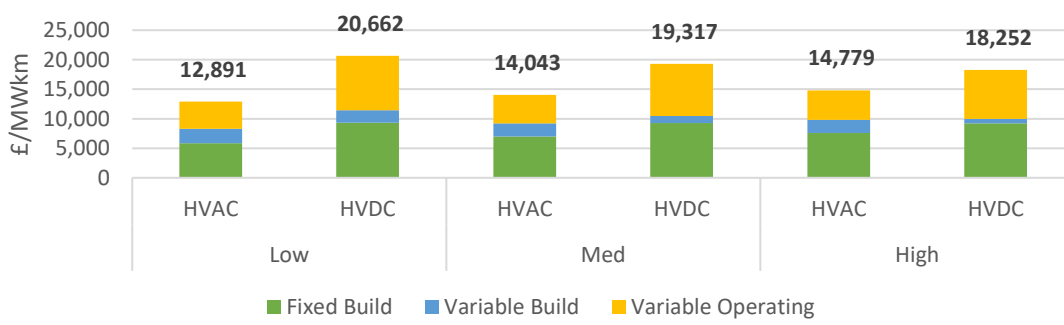

Figure 4.9: Offshore Technologies – 180 km Comparison

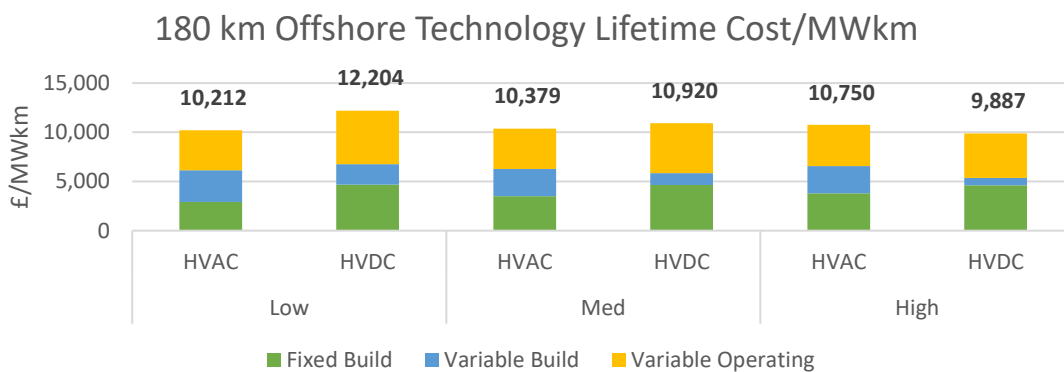
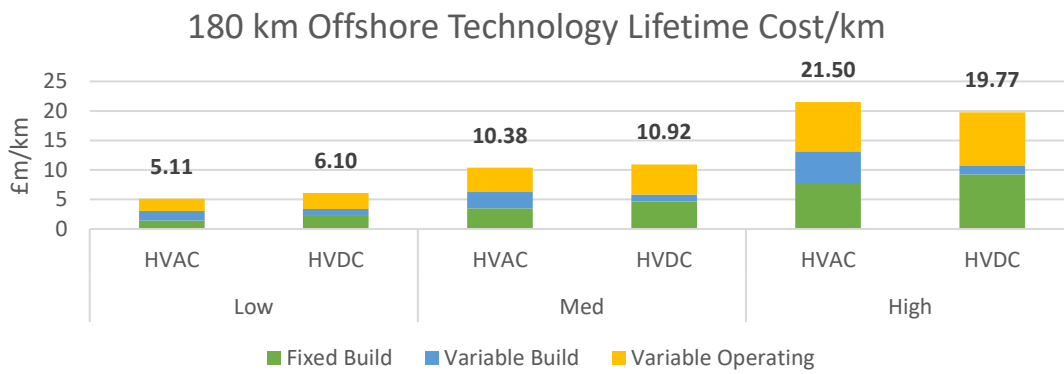
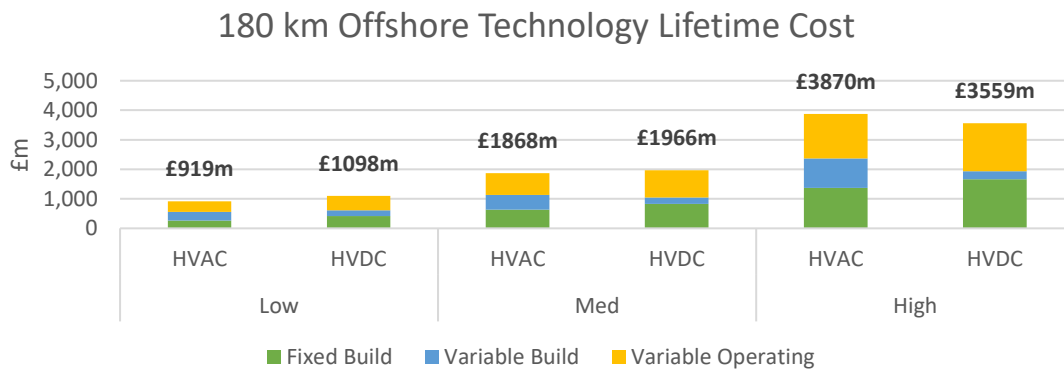
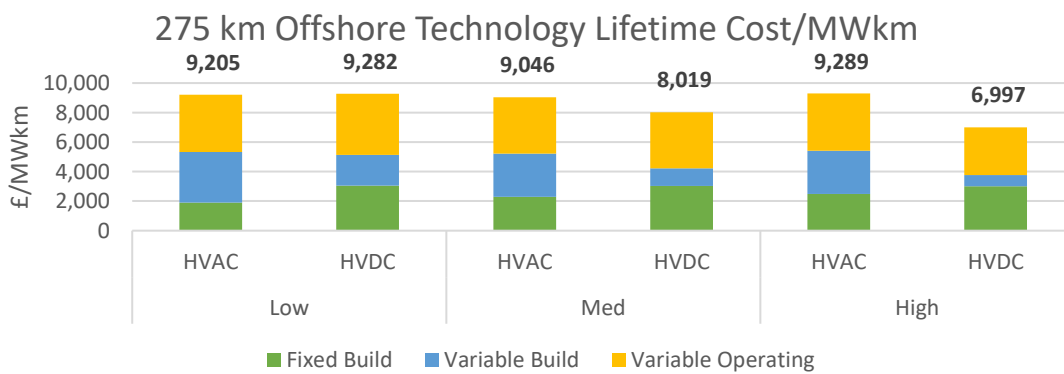
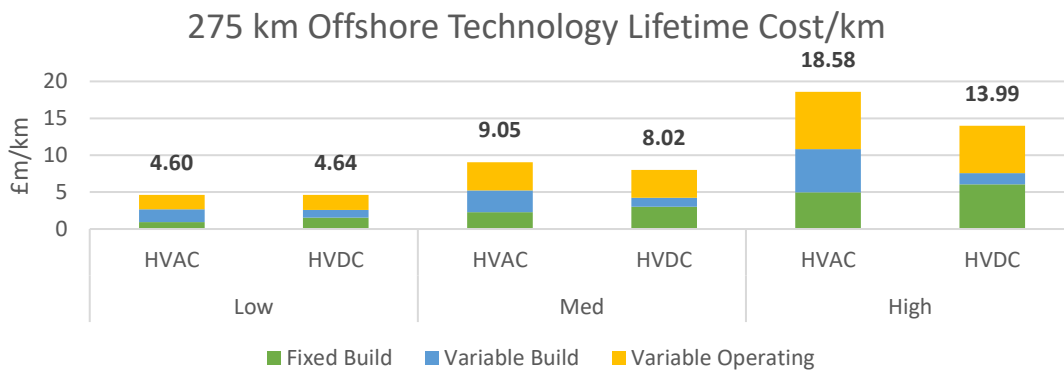
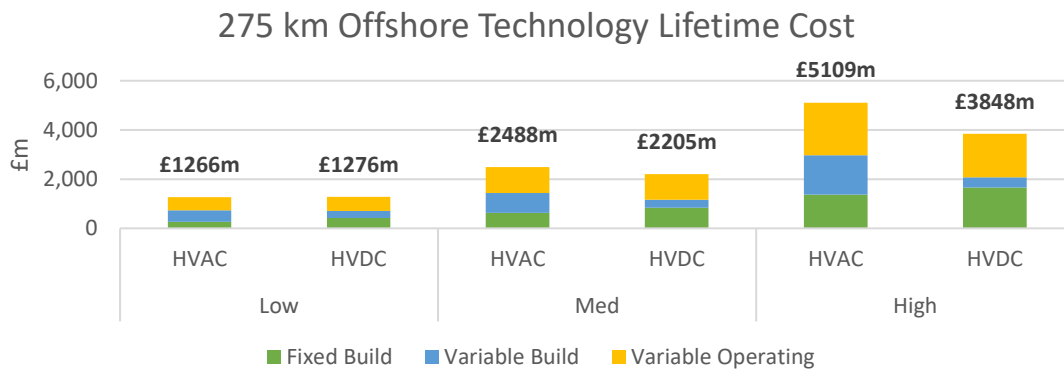

Figure 4.10: Offshore Technologies – 275 km Comparison



5 Discussion of Cost and Non-Cost Characteristics

This section of our report draws upon the findings of the cost and ratings assessment and also adds an evaluation of non-cost characteristics to provide a comparison in relative terms of the different technologies studied.

In addition to cost, technology selection is also influenced by a variety of non-cost characteristics, each of which is contextual and project specific.

In writing this report we have considered the following non-cost characteristics:

Table 5.1: Non-cost factors considered

Criteria	Criteria
Environmental	Direct and indirect impact on the environment during both construction and operation
Carbon	Carbon content during construction and operations
Local Impact	Direct and indirect impact on local communities during construction and operation
Technology Readiness	Considers both the technology readiness level (TRL) and also GB experience
Technology Adaptability	Adaptability during installation and for future system needs
Technology Resilience	Considers resilience to high wind speed and flooding, and mean time to repair (MTTR)
Programme	Considers pre-construction logistics and timeline, as well as construction programme duration

As part of developing this report, we sought to agree, with the Project Board, a methodology for ranking the technologies in respect of their performance against the above criteria. From the work we have done, it is evident that the assessment of non-cost characteristics is highly dependent on the context within which the project is deployed. For example, a project to be deployed in mountainous terrain in Scotland may be assessed in a very different manner to a project in a densely-populated area in England. We have concluded that producing a generic (as opposed to project-specific) ranking methodology, and the appropriate application of different weighting factors, was difficult and potentially misleading. Therefore, a qualitative description of non-cost characteristics of each technology has been included within the report, based on the knowledge and experience of the Mott MacDonald project team.

For technology readiness we have included the technology readiness level (TRL) published by ENTSO-E for the specific technology, as shown in the following table:

Table 5.2: TRL Description

TRL	Definition
1	Basic principles observed.
2	Technology concept formulated.
3	Experimental proof of concept.
4	Technology validated in lab.
5	Technology validated in relevant environment (industrially relevant environment in the case of key enabling technologies).
6	Technology demonstrated in relevant environment (industrially relevant environment in the case of key enabling technologies).
7	System prototype demonstration in operational environment.

TRL	Definition
8	System complete and qualified.
9	Actual system proven in operational environment (competitive manufacturing in the case of key enabling technologies; or in space).

Source: "Technology Readiness Levels", ENTSO-E. Available: <https://www.entsoe.eu/Technopedia/trls/>

The following table presents each technology considered in the study, lists the range of costs calculated, and presents our conclusions, taking into consideration both these and the non-cost characteristics. We have also indicated the average lifetime power transfer cost of the cases studied for each technology, rounded to three significant figures. Colour coding is used to indicate the source of the data used for estimating as introduced in Section 4.1.

As described elsewhere, the comparison is presented in relative terms and, whilst it is valid to compare some technologies directly against others (such as overhead lines against underground cables), a simple comparison would not be valid in all instances (for example, an offshore embedded HVDC link against an onshore overhead line) as the technologies contribute to the overall network capability in different ways. However, the assessment is considered to be indicative of broad trends for each technology. It is assumed that the technology is being deployed in a situation to which it is suited, noting that not all technologies can be deployed across all environments.

Table 5.3: Cost and non-cost characteristics – onshore technologies

Technology and Cost	Criteria	Mott MacDonald Comments
Onshore Technologies – double circuit installation evaluated for 3, 15 and 75 km and high/medium/low rating unless otherwise stated		
400 kV Overhead Line <ul style="list-style-type: none"> ● Build: £7m - £221m ● Lifetime: £11m - £602m ● Lifetime £/km: £3m - £9m ● Lifetime £/MWkm: £1,012 - £1,492 ● Average Lifetime £/MWkm: £1,190 ● Data Source: TO and supply chain data 	Cost Commentary	Over the distances evaluated, this is the most cost-effective method of bulk power transmission.
	Rating/Capacity/Distance	OHL can achieve higher ratings than underground cables. The rating of the circuits in this study is limited by the assumption that a circuit will generally include a cable section. If a pure overhead line route can be achieved then improvements on the cost ranges can be realised.
	Environmental Impact	During construction, vegetation clearance is required to establish a route. However, as compared to cables, continuous excavation along the route is not required, with excavations confined to tower locations. During operation, there is a need for vegetation clearance to maintain a “corridor” with adequate clearance for the high-voltage conductors.
	Carbon Intensity	Embodied carbon content for OHL is considered to be similar to that of UGC. Whilst there is a low amount of civil works and associated concrete required, this is offset by a larger quantity of metal. Aluminium alloy conductor and steel towers make up a large proportion of the embodied carbon content.
	Local Impact	Continued visual impact during the operational period. During construction, as compared to underground cables, there is likely to be less noise and less traffic, due to the lower amount of excavation. If the route includes a cable section, then it is necessary to establish a permanent compound to transition from overhead line to underground cable.
	Technology Readiness	TRL 9. The technology is well established having been used for many decades with technological advances continuing to be implemented.
	Technology Adaptability	It is not well suited to negotiating obstacles such as urban areas, although it is generally straightforward to cross watercourses, roads or railways and undulating terrain. Once a route is established, there is potential for this to be adjusted to a different voltage level, different conductor type, or changed from HVAC to HVDC, subject to appropriate design. Relatively straightforward to tee into an existing OHL circuit or divert into a nearby new facility.
	Technology Resilience	Simple technology, proven over many decades. Whilst it is exposed to the elements, it is reasonably resilient and repair times are relatively quick. A fault can usually be restored within hours or days, thus restoring the system to its full level of redundancy much more quickly than an underground cable system. However, more susceptible to extreme wind and temperatures than other technologies.
	Programme	As compared to underground cable systems, the construction programme is expected to be quicker. However, the pre-construction programme can be lengthy, and, depending on the location, there can be challenges around securing the necessary planning permissions. Conductors and fittings are generally commodity items with no significant lead time. However, towers are likely to take longer to supply. Once construction has commenced, the overall programme can be relatively efficient.

Technology and Cost	Criteria	Mott MacDonald Comments
400 kV Underground Cable <ul style="list-style-type: none"> ● Build: £44m - £2,147m ● Lifetime: £50m - £2,486m ● Lifetime £/km: £14m - £39m ● Lifetime £/MWkm: £4,429 - £6,700 ● Average Lifetime £/MWkm: £5,330 ● Data Source: TO and supply chain data 	Cost Commentary	The build cost for a cable system is between six and ten times that of an equivalent overhead line system, with the difference being greater for longer distances and higher power transfers. The lifetime cost of an underground cable system is around four to five times that of an equivalently-rated overhead line system.
	Rating/Capacity/Distance	It is technically challenging to match the power transfer capacity of an overhead line. Reactive compensation equipment and, depending on the length of the circuit, multiple intermediate stations may be required. There is a physical limitation as to the distance over which it can be used without an intermediate station. Where higher power transfers are required, which necessitate multiple conductors per phase, space restrictions can become an issue. As per figure E4, for a high power application with three conductors per phase, the land requirement could be up to 60m wide for the final installation, with 80m or more required for construction. For an overhead line we would expect this to be in the region of approximately 50m (refer to Section D.3).
	Environmental Impact	The impact during installation is considered greater than that of an overhead line due to the need for continuous excavations along the route, with the impact getting worse for higher ratings. Disposal of excavated material may be required. However, once completed the environmental impact is typically less than that of an OHL (although this may not be the case in all environments). There is also a need to manage the makeup of the ground for the life of the asset as a result of the buried equipment (e.g. to maintain a “corridor” in which tree planting must be controlled). In the event of a repair further excavations would be required.
	Carbon Intensity	Embodied carbon content for UGC is considered to be similar to that of OHL. Whilst there is a larger amount of civil works and associated concrete required for an UGC, this is offset by a lower quantity of metal. The cable materials and the backfill material make up the majority of the carbon content.
	Local Impact	Underground cables are effective at minimising the visual impact of transmission infrastructure, following post-construction land remediation. However, as with overhead lines, a ‘corridor’ must be maintained in which tree planting must be controlled with an associated visual impact. Due to the need for excavation along the entire route, it can take some time for the land to recover and, in some instances, “scarring” can remain visible. Following completion of construction, small-scale vegetation can be allowed to grow back. During construction there could be a greater amount of noise and traffic movements due to the need for excavations along the entire route. Required clearance to cable circuits is less than that of overhead lines.
	Technology Readiness	TRL 9. Underground cables are well established technology with technological advances continuing to be implemented.
	Technology Adaptability	Well suited to achieving low power transfers in urban environments but, where higher power transfers are required which necessitate multiple conductors per phase, space restrictions can become an issue. Installation in areas with challenging terrain or ground conditions can be difficult. However, can be direct-buried or installed in ducts to suit different requirements. Special constructions, such as horizontal directional drilling, may be required for negotiating obstacles, such as rivers, roads and railways, which add to the cost and complexity.

Technology and Cost	Criteria	Mott MacDonald Comments
		<p>Installation techniques such as HDD can be used to overcome obstacles. Can be operated at lower voltage levels than designed but not suitable for upgrading to higher voltage levels or changing from HVAC to HVDC. Diversion of UGC circuits requires excavation and cutting into existing circuits.</p> <hr/> <p>Technology Resilience Whilst the technology is buried underground and less susceptible to weather events, in the event of failure repair times can be lengthy, lasting weeks or months. Extreme high temperatures could result in failure if de-rating is not implemented. Fault location, maintenance and repair is more complex than that of overhead lines, generally requiring the faulty section of cable to be excavated, cut out and replaced with a new section. This can be a lengthy process, lasting weeks or months depending on the situation. Statistically a longer cable will have a higher probability of failure.</p> <hr/> <p>Programme The construction programme for an underground cable, including material lead times, is expected to be longer than an overhead line. Lead time on supply of cable can extend the programme due to linear manufacturing processes and limited factories. Programme can be logistically more challenging than overhead lines. Jointing, termination and testing requires specialist resource, with restricted availability providing a programme constraint.</p>
<p>400 kV Underground Cable in Tunnel</p> <ul style="list-style-type: none"> ● Build: £169m - £4,047m ● Lifetime: £185m - £4,570m ● Lifetime £/km: £52m - £83m ● Lifetime £/MWkm: £8,145 - £24,658 ● Average Lifetime £/MWkm: £14,100 ● Data Source: TO and public domain data 	<p>Cost Commentary</p> <hr/> <p>Rating/Capacity/Distance</p> <hr/> <p>Environmental Impact</p> <hr/> <p>Carbon Intensity</p> <hr/> <p>Local Impact</p>	<p>The build cost for a cable in a tunnel is very high, being around two to four times higher than an equivalently-rated underground cable system. Going from a low-rated design to a medium results in increased costs, due to the increase in tunnel diameter from 3 m to 4 m, and quantity of conductors per phase from one to two. However, a high-rated tunnel can still be achieved with a 4 m diameter and two conductors per phase, thus the construction cost only increases slightly between these options. Therefore, a tunnel with a high rating provides greater value for money.</p> <p>It is technically challenging to match the power transfer capacity of an overhead line. However, higher ratings are achievable per cable than in a direct buried application (due to better heat dissipation from the cable).</p> <p>Reactive compensation equipment and, depending on the length of the circuit, multiple intermediate stations may be required.</p> <p>Physical limitation as to the distance over which it can be used without an intermediate station.</p> <p>During construction it is not necessary to undertake open excavations along the route, only at shaft locations, although the construction sites for these tend to be significant. The above-ground environmental impact during construction is generally limited to the shafts and head-house locations. Shafts are required at regular intervals, thus the greater the route length, the greater the environmental impact. The construction of the tunnel for the length of the route results in removal of significant quantities of earth, and generally a substantial amount of excavated material must be disposed of. The tunnel is a significant permanent below-ground structure and thus there is an impact on the makeup of the ground for the life of the asset with associated impact on hydrology, below-ground habitats and similar.</p> <p>The large amount of civil work, quantity of excavated material, and associated transportation to/from site, results in an increased carbon content as compared to underground cables or overhead lines.</p> <p>During construction, it is not necessary to excavate along the route, only at shaft locations, although the construction sites for these tend to be significant. There are likely to be reasonable volumes of construction traffic, including heavy plant movements at these locations.</p>

Technology and Cost	Criteria	Mott MacDonald Comments
		The visual impact following completion of construction is limited to the shafts and head-houses. Shafts are required at regular intervals, thus the greater the route length, the greater the visual impact.
	Technology Readiness	TRL9. Well-established technology which has been in use since the 1960s in GB, thus providing significant operational in-service history and in-country experience. However, use in GB to date is not substantial and is generally restricted to dense urban areas or the crossing of obstacles, such as watercourses.
	Technology Adaptability	Tunnels are well suited to navigating obstacles, such as significant watercourses and densely populated urban areas. Once built, alterations to tunnel infrastructure are difficult to implement. If planned in advance, additional cables can be installed in the tunnel at a later stage. Cables can be removed from tunnels making space for new assets. Tunnels can be extended to be routed to new locations. Cable system design can be optimised due to the consistent installation environment, whereas direct buried ratings are limited by the worst-case conditions.
	Technology Resilience	Due to being installed underground, generally resilient in respect of extreme weather events, although: Tunnels are equipped with ventilation systems to manage cable temperatures, the effectiveness of which could be impacted by extreme high temperatures or increased ambient temperatures. Tunnels are equipped with drainage systems and could be impacted by flooding or extreme rainfall if not appropriately designed, operated and maintained. Fault location and repair is more complex than for overhead lines and is similar to that of standard cable systems. Whilst excavation is not necessary, equipment will need to be transported into the tunnel system itself, and staff may need to be suitably trained for tunnel access. Repair times may be extended due to working in a confined space. Statistically a longer cable will have a higher probability of failure.
	Programme	Planning and consenting process for tunnel systems can be of significant duration. Enabling works, including construction of head-houses and access points, requires significant upfront works. Complex logistical exercise due to scale of civil works required. Extent of civil works means programme is likely to be longer than that of OHL or UGC for a given circuit length.
275 kV Pressurised Air Cable (2.3 GW) <ul style="list-style-type: none">● Build: £54m - £1,084m● Lifetime: £62.24m - £1,257m● Lifetime £/km: £17m - £21m● Lifetime £/MWkm: £3,593 - £4,445● Average Lifetime £/MWkm: £3,950● Data source: single supplier plus derivation from other technologies – comparatively lower level of cost certainty	Cost Commentary Rating/Capacity/Distance Environmental Impact	This is an emerging technology and, due to the lack of cost data, the level of price certainty is lower for this technology. When compared with a medium-rated underground cable system, the build cost for the pressurised air cable is expected to be lower as it can be accommodated in a single trench, and the lifetime cost per km is also lower. The overall lifetime power transfer cost is around 0.8 times that of a similarly rated a.c. underground cable. Given that similar power transfers are being achieved with a single conductor per phase at 275 kV as compared to two conductors per phase at 400 kV, there may be efficiencies as a result of this approach which are not currently recognised in our calculations, which could make this an effective solution. A manufacturer has supplied data indicating a 5,000 A capacity with ratings up to 300 kV currently available. We have therefore considered a system with a single 5,000 A conductor per phase operating at 275 kV which provides a similar power rating to a medium rated 400 kV a.c. cable system, which uses two conductors/phase. It could have advantages over cable technology as, for a medium rated case, it can be accommodated in a single trench with an associated reduction in environmental impact. Excavation along the entire route would be required,

Technology and Cost	Criteria	Mott MacDonald Comments
		with associated environmental impact. There is an impact on the makeup of the ground for the life of the asset as a result of the buried equipment. In the event of a repair further excavations would be required.
	Carbon Intensity	Carbon intensity likely to be similar to that of an underground cable.
	Local Impact	It could have advantages over cable technology as it can be accommodated in a single trench with an associated reduction in construction impact. Excavation along the entire route would be required, with associated construction related impact in the local area (e.g., traffic, noise, etc.). It can take some time for the land to recover and, in some instances, "scarring" can remain visible. Following completion of construction, small-scale vegetation can be allowed to grow back, but a "corridor" must be maintained with associated visual impact.
	Technology Readiness	Not yet proven in service, although proven in test environments. Whilst the comparatively low technology readiness level may prove to be a barrier in the short term, this technology could be deployable in the medium term once fully proven. All demonstrations to date are outside GB.
	Technology Adaptability	Adaptability considered to be similar to that of an underground cable system. However, as it can achieve a medium rating in a single trench, it could have advantages in areas where space constraints exists, as compared to an underground cable.
	Technology Resilience	Whilst the infrastructure is buried underground and thus less susceptible to weather events, pressurisation stations may be required along with a monitoring system. Should these fail then they could impact on the capability of the system to operate at the assigned rating. Operation and maintenance of these systems will need to be considered. However, given that the technology has no service history, there is little substantive evidence in this regard at the present time.
	Programme	For a medium-rated application, the construction programme is likely to be slightly shorter than that of an underground cable system, as only a single trench is required. Emerging technology requiring specialist skill-set for installation, jointing and termination, with limited resource pool.
132 kV Superconducting Cable (1.4 GW) <ul style="list-style-type: none"> ● Build: £61m - £1,304m ● Lifetime: £69m - £1,501m ● Lifetime £/km: £20m - £23m ● Lifetime £/MWkm: £7,291 - £8,424 ● Average Lifetime £/MWkm: £7,780 ● Data source: public domain plus derivation from other technologies – comparatively lower level of cost certainty 	Cost Commentary	This is an emerging technology and due to the lack of cost data the level of price certainty is low for this technology. The case we have considered has a similar rating to a low-rated a.c. cable. When comparing these two technologies, the build cost for the superconductor is higher due to the high cost of the cable system and associated cooling infrastructure. The lifetime cost per km is around 1.4 times that of an a.c. cable system, and the lifetime power transfer cost is around 1.3 times greater. Given that similar power transfers are being achieved at 132 kV as compared to 400 kV, there may be efficiencies as a result of this approach which are not currently recognised in our calculations, which could make this an effective solution. For example, it may negate the need for the construction of additional infrastructure such as substations and transformers
	Rating/Capacity/Distance	Can achieve similar power transfers to a low-rated 400 kV underground cable system at 132 kV. Effectively no resistance-based power loss or heat loss. Not proven in long cable routes which may potentially need multiple cryogenic cooling facilities.
	Environmental Impact	Likely to be similar to that of an underground cable system, due to similar installation methodology. Potential for leakage of the liquid nitrogen coolant but impact comparatively lower than that of SF ₆ gas. Use of rare earth

Technology and Cost	Criteria	Mott MacDonald Comments
		materials required for manufacture of the cable. There is an impact on the makeup of the ground for the life of the asset as a result of the buried equipment. In the event of a repair further excavations would be required.
	Carbon Intensity	Expected to be similar to that of an underground cable system. Additional carbon content as a result of liquid nitrogen cooling system, but this is comparatively less than that of SF ₆ .
	Local Impact	Likely to be similar to that of an underground cable system, due to similar installation methodology. However, space will be required for the cooling systems.
	Technology Readiness	TRL7. Whilst this is still an emerging technology, it has undergone significant development in recent years with several examples of commercial operation now available, although it is not yet proven in long-term service. The cooling and monitoring system has both installation and operation and maintenance impacts, but the techniques required to install the cable itself are similar to those of a conventional cable.
	Technology Adaptability	Given that similar power transfers are being achieved at 132 kV as compared to 400 kV, it may negate the need for the construction of additional infrastructure, such as substations and transformers, which could also lead to it being considered for use when space constraints are an issue, for example in dense urban areas. Phases can be installed in close proximity to each other, so the system takes up less space than some other technologies. Otherwise the adaptability is considered to be similar to that of an underground cable system.
	Technology Resilience	Whilst the infrastructure is buried underground and thus less susceptible to weather events, cooling and monitoring systems are required. Fault location, maintenance and repair is more complex than that of standard UGC due to the specialist nature of the superconducting cable. Generally requires the faulty section of cable to be excavated, cut out and replaced with a new section. In the event of loss of cooling system then the system would need to be shut down. Can be mitigated to an extent through appropriate design measures. Operation and maintenance of these systems will need to be considered. However, very little service history on which to evaluate the resilience long-term. Cooling system could be susceptible to extreme heat weather events.
	Programme	Likely to be similar to that of an underground cable system, due to similar installation methodology. Whilst there are additional programme considerations relating to the cooling and monitoring system, these may be offset as some additional supporting infrastructure such as transformers from 400/132 kV may not be required. Emerging technology requiring specialist skill-set for installation, jointing and termination, with limited resource pool.
Reconductoring using HTLS conductor (75 km only) <ul style="list-style-type: none"> ● Build: £90m ● Lifetime: £371m ● Lifetime £/km: £4.94m ● Lifetime £/MWkm: £1,980 ● Data Source: Limited pool of TO data 	Cost Commentary	The build cost for this technology is very low due to the re-use of existing infrastructure. The lifetime costs only considered the additional capacity which is created, and the associated losses, with £4.94m/km being of the same order of magnitude as the other 75 km overhead line systems studied, while the lifetime power transfer cost of £1,981/MWkm is slightly higher than that of the other overhead line systems, although still comfortably less than equivalent underground cable circuit.
	Rating/Capacity/Distance	We have used a limited pool of TO data to undertake our assessment of this scenario, which considers reconductoring of an existing medium-rated overhead line with HTLS, resulting in a capacity similar to that of a “high” rating. This “additional” capacity created is less than that of constructing a new line and values in the order of 40 – 100% can be expected
	Environmental Impact	Low environmental impact due to reuse of existing infrastructure (towers) and existing routes

Technology and Cost	Criteria	Mott MacDonald Comments
	Carbon Intensity	Based largely on re-use of existing towers with relatively minor modifications expected. Embodied carbon content is therefore mainly limited to that of the new conductor system.
	Local Impact	Low local impact as no need to establish a new route or undertake excavations. Activities generally restricted to replacement of conductors. No noticeable change in appearance of reconducted line as compared to existing line
	Technology Readiness	TRL9. Well established technology, in use in GB.
	Technology Adaptability	Not all lines are suitable for reconductoring. Does not consider any changes to existing routes. Only a limited amount of additional capacity can be gained. Can only be applied to existing routes.
	Technology Resilience	Considered to be the same as standard overhead lines
	Programme	Due to reuse of existing infrastructure this technology can be deployed quickly, expediting the design and construction programme.
400 kV Overhead Line using T-Pylons (15 km and 75 km, 4,988 MW double circuit rating) <ul style="list-style-type: none"> ● Build: £83m - £414m ● Lifetime: £130m - £648m ● Lifetime £/km: £8.64m ● Lifetime £/MWkm: £1,730 ● Data Source: TO and public domain data 	Cost Commentary	Evaluated on the basis of a medium rating and medium route length solution, as this is what data has been available for. The build cost is approximately 2 to 2.5 that of an equivalently-rated conventional overhead line, and the lifetime costs are around 1.6 to 1.7 times that of a conventional overhead line. However, it is still significantly less than an equivalent underground cable at around 0.35 to 0.37 times the lifetime cost. They are also expected to have lower maintenance requirements.
	Rating/Capacity/Distance	Only example to date uses a medium rating. Unclear if a high rating can be achieved, but likely to be suitable for use over short to medium distances for low and medium-rated applications.
	Environmental Impact	Depending on the context in which they are deployed, T-pylons can sometimes be considered to have a reduced environmental impact as compared to conventional overhead lines, due to smaller land-take. Similar to conventional overhead lines, excavations are limited to pylon locations.
	Carbon Intensity	As compared to standard OHL installation, T-pylons contain a greater quantity of steel and larger foundations. Depending on the location, they may also require more substantial access roads. Construction programme expected to be shorter than that for standard OHL systems with corresponding reduction in construction-related carbon content.
	Local Impact	Can sometimes be considered to have an improved visual appearance as compared to lattice tower designs, although the level of improvement which can be achieved (if any) is highly situation-dependent. More robust access roads generally required as compared to lattice towers, due to installation methodology. During operations, vehicular access must be maintained as T-Pylons cannot be climbed and so access is via MEWP.
	Technology Readiness	TRL8. Limited in-service experience with only a single operational example in GB. However, components used are generally proven in lattice tower overhead line applications.
	Technology Adaptability	Not suitable for deployment in all locations and may require a greater quantity of permanent access roads to be installed, as T-pylons cannot be climbed. Less adaptable to different terrains as they cannot achieve such tight turning angles as compared to conventional overhead lines.

Technology and Cost	Criteria	Mott MacDonald Comments
	Technology Resilience	Resilience is likely to be similar to that of overhead lines. However, fault restoration and repair times may be slightly extended (although still significantly shorter than those of underground cable systems) as access equipment will be required, as the T-Pylons are not suitable for climbing
	Programme	Depending on their application, there could be a shorter installation programme duration as compared to steel lattice type towers as the pylons themselves are delivered in a small quantity of pre-fabricated lengths, whereas steel lattice towers generally require assembly on site.

Table 5.4: Cost and non-cost characteristics – long-distance onshore transmission

Long-Distance Onshore Transmission (700 km)		
Onshore HVDC VSC 525 kV Underground Cable (2 GW, 700 km) <ul style="list-style-type: none"> ● Build: £1,867m ● Lifetime: £3,182m ● Lifetime £/km: £4.55m ● Lifetime £/MWkm: £2,270 ● Data source: <i>derivation from other technologies – comparatively lower level of cost certainty</i> 	Cost Commentary	The build cost for this solution is relatively high, partly due to the fixed costs of the converter stations, but also due to the length. This solution cannot be readily compared against others which have been studied. However, it demonstrates the efficiencies of d.c. technology over long distances. It is unlikely that an a.c. overhead line solution would be able to achieve the lifetime power transfer cost exhibited by the HVDC system over the distance studied.
	Rating/Capacity/Distance	The rating which can be achieved is limited to 2 GW and multiple links would be required to achieve similar ratings to a.c. overhead lines. Long-distance solution, not readily comparable to the 400 kV solutions which have been studied.
	Environmental Impact	<p>The construction works would have an environmental impact due to the construction of the converter stations and excavation of the lengthy cable route. During operations there would be ongoing environmental impacts due to the need to maintain a corridor in which tree-planting must be controlled.</p> <p>Impacts similar to those of UGC and HVDC VSC solution, including right of way clearance, access roads, excavations and general construction impact. There is an impact on the makeup of the ground for the life of the asset as a result of the buried equipment. In the event of a repair further excavations would be required.</p>
	Carbon Intensity	<p>Expected to be a sizeable quantity of embodied carbon as a result of the need to construct two converter stations and install a long UGC route.</p> <p>Carbon impact generally as per UGC and HVDC VSC solution.</p>
	Local Impact	Visual impact would primarily be associated with the converter stations. There would also be an impact as a result of the cable route, similar to that listed for a 400 kV a.c. underground cable system, albeit over a considerably greater distance.
	Technology Readiness	TRL9. Established technology in GB. Whilst not used for onshore transmission, the application would be no different to that for offshore use. Onshore HVDC cable systems are established technology and in use in GB.
	Technology Adaptability	<p>Similar considerations to conventional 400 kV underground cable systems.</p> <p>Power transfer capability is limited compared to HVAC but this length would not be achievable using HVAC.</p> <p>No requirement for reactive power compensation/intermediate stations.</p> <p>May offer additional network services, as per HVDC VSC section.</p>

		Point-to-point solution which cannot “tap in” to other stations along the route without additional technical complexity and significant additional cost due to the need for a converter station.
	Technology Resilience	Cable is of significant length and statistically a longer cable will have a higher probability of failure. Similar considerations apply as for 400kV underground cable systems, including potentially lengthy durations for fault location and repair.
	Programme	Programme would be expected to be lengthy. Manufacturing such a length of cable would require significant factory capacity and would likely involve a significant lead time. Physical installation works for the cable would be of significant duration. Obtaining permits and consents for such a lengthy route would likely be challenging and require significant time. No significant issues expected in relation to the upfront design as converter station and cable designs for this rating already exist, albeit they have not yet been implemented in GB.
Onshore HVDC LCC 800 kV Overhead Line (8 GW, 700 km) <ul style="list-style-type: none"> ● Build: £4,059m ● Lifetime: £9,400m ● Lifetime £/km: £13.43m ● Lifetime £/MWkm: £1,680 ● Data source: derivation from other technologies – comparatively lower level of cost certainty 	Cost Commentary	The build cost is high due to the long route length and high fixed cost of the converter stations. However, the lifetime cost per km (£13.43m) and lifetime power transfer costs (£1,679) are relatively economical. The construction programme would be expected to be lengthy. The costs do not consider the work which may be required to divert existing circuits into the converter station. Further, a point-to-point link of this capacity may have wider system impacts and could trigger the need for work elsewhere, which has also not been factored in.
	Rating/Capacity/Distance	This scenario considers an overhead line with two phase conductors and a metallic return, providing the functionality for operation at half capacity under certain situations. Long-distance solution, not readily comparable to the 400 kV solutions which have been studied.
	Environmental Impact	Towers would be larger than a 400 kV a.c. solution, with corresponding environmental impact, but there would be a reduced land-take, and thus reduced environmental impact, compared to the single circuit UHV overhead line below. However, a very large area would be required for each converter station with associated environmental impact. Overall, due to the length of the route and size of converter stations, there are likely to be significant environmental challenges with the deployment of such a solution in GB. Excavations along the route would be expected to be confined to tower locations
	Carbon Intensity	Expected to be a sizeable quantity of embodied carbon as a result of the need to construct two converter stations and install a long OHL route. Carbon impact generally as per OHL and HVDC VSC solutions.
	Local Impact	The visual impact is expected to be greater than that of a 400 kV a.c. overhead line due to larger towers, but less than that of the UHV overhead line below. A very large area would be required for each converter station with associated visual impact and land-take. Construction works would be significant at the converter station locations with corresponding local impact
	Technology Readiness	TRL9. LCC converter technology is well established and has been used in GB. OHL systems at these voltage levels or operating using HVDC are not established in GB and would require development of new OHL/tower designs and operational parameters. However, such systems are common in other countries such as China, Russia, India, Brazil and others.
	Technology Adaptability	Due to the possibility of operating at half capacity, using only a single overhead line circuit, the system offers more operational flexibility as compared to the single circuit a.c. UHV overhead line.

		<p>Restricted to an overhead line solution as 800kV cables have not yet been developed. Thus if there is a section of the route which would require a cable system, this would not be achievable.</p> <p>Adapting the network to achieve compliant post-fault conditions could be challenging and could constrain the use of the additional capacity.</p> <p>Point-to-point solution which cannot “tap in” to other stations along the route without additional technical complexity and significant additional cost due to the need for a converter station.</p>
	Technology Resilience	Similar considerations to onshore 400 kV OHL and HVDC VSC solution.
	Programme	Programme would be expected to be lengthy. As Technology is not established in GB, there would be upfront work required to establish designs/standards/specifications and operational parameters. Physical installation works for the OHL route would be of significant duration. Obtaining permits and consents for such a lengthy route would likely be challenging and require significant time. Manufacturing of such a quantity of towers may have a programme impact. Construction programme for the converter stations would likely be of significant duration. Could be complexities associated with scheduling outages on the wider network to accommodate such a solution.
<p>765 kV Overhead Line a.c. transmission (8GW, 700 km)</p> <ul style="list-style-type: none"> ● Build: £1,925m ● Lifetime: £4,944m ● Lifetime £/km: £7.06m ● Lifetime £/MWkm: £880 ● Data source: derivation from other technologies – comparatively lower level of cost certainty 	Cost Commentary	The build cost is not as high as that of the 700 km HVDC solution, resulting in lifetime costs of £7.06m/km and £883/MWkm, which are roughly half that of the HVDC solution. However, if two circuits were constructed to provide redundancy then it is likely that the figures would be comparable. Under such circumstances, the land-take, environmental impact and visual impact would also increase significantly, which may make it prohibitive. The costs do not consider the work which may be required to divert existing circuits into the 765 kV substation. Further, a point-to-point link of this capacity may have wider system impacts and could trigger the need for work elsewhere, which has not been factored in.
	Rating/Capacity/Distance	This solution considers only a single circuit, thus if there is a fault then the entire capacity of the circuit is lost. Long-distance solution, not readily comparable to the 400 kV solutions which have been studied.
	Environmental Impact	Environmental impact due to lengthy OHL route and need for substation extensions to accommodate new transformers. Towers would be larger than for 400 kV a.c. with corresponding increase in environmental impact. Generally the environmental impact would be similar to those of 400 kV OHL including right of way clearance, access roads, general construction impact and ongoing tree cutting requirement. Excavations along the route would be expected to be confined to tower locations.
	Carbon Intensity	Expected to be a sizeable quantity of embodied carbon as a result of the need to construct substation extensions and install a long OHL route. Carbon impact generally as per OHL section but additional impact as a result of the need for step-up transformers.
	Local Impact	Increased visual impact of towers as they will be larger than current towers and route is longer. Local impact as a result of general construction issues associated with lengthy OHL route. Similar local impact to OHL along with requirement for substation extensions. These would be required at each end, would likely be sizeable and require significant land-take with associated localised construction works impact. Large transformers would need to be delivered to the substation extensions with associated transportation issues.
	Technology Readiness	TRL9. While technology has been deployed in some countries, it is not established in GB, and would necessitate new OHL/tower/transformer/substation designs and operational requirements.

Technology Adaptability	Restricted to use in overhead line systems – 765kV UGC not yet proven. Unclear if a pure OHL route of this length could be achieved in GB. Would require installation of additional transformer stations to convert to lower voltage levels, which would likely occupy a relatively large footprint. Other considerations as per 400 kV OHL section.
Technology Resilience	Similar considerations to onshore 400 kV OHL.
Programme	Programme duration would be expected to be lengthy. As technology is not established in GB, there would be upfront work required to establish designs/standards/specifications and operational parameters. Physical installation works for the OHL route would be of significant duration. Obtaining permits and consents for such a lengthy route would likely be challenging and require significant time. Manufacturing of such a quantity of towers may have a programme impact. As equipment of this voltage level has not been used in GB before, there could be an extended design, manufacturing and testing programme. Substations at each end would be sizeable with reasonably long duration construction programmes. Could be complexities associated with scheduling outages on the wider network to accommodate such a solution.

Table 5.5: Cost and non-cost characteristics – increased use of existing capacity

Onshore – Increased use of Existing Capacity		
Quadrature Booster (2,750 MVA, on-off installation) <ul style="list-style-type: none"> Build: £35m - £40m Data Source: single source 	Cost Commentary	We have not estimated lifetime costs for this technology as the amount of existing thermal capacity which can be freed up is very project specific. As such only the build cost has been estimated.
	Rating/Capacity/Distance	It is important to note that this technology does not create additional thermal capacity, but maximises the use of existing capacity.
	Environmental Impact	Whilst the device itself contains large quantities of oil, direct environmental impacts during construction and operation are largely mitigated through design measures. Main environmental impact is as a result of any substation extension required.
	Carbon Intensity	Contains large quantity of oil along with steel, copper and iron, with associated embodied carbon. Usually requires extension of substation and large concrete foundation and bund.
	Local Impact	Generally located on existing substations so minimal increased impact to local communities. Will be a localised impact during construction works, particularly during delivery of the QB as it is physically very large.
	Technology Readiness	TRL9. Well-proven technology which has been used since the 1960s.
	Technology Adaptability	Does not create additional capacity, is limited to making best use of existing capacity. QBs are very large devices, with significant relocation difficulties. The quadrature booster does offer dynamic power flow control, but is not readily adaptable to changing system needs, and it is unlikely it can be moved elsewhere at a later date.

	Technology Resilience	Ongoing operation and maintenance requirements including periodic oil processing. Largely comparable to standard substation equipment which can be susceptible to weather events due to being located outdoors. However, risk can be minimised through appropriate design measures.
	Programme	Large construction and transport logistical hurdles due to device being, in essence, two transformers. Manufacturing timeframe is likely to be extensive. Substation extension and reasonable quantity of civil works required.
Static Series Synchronous Compensator (typical installation) 1. Build: £16m - £18m 2. Data Source: Limited TO and supplier data set	Cost Commentary	We have not estimated lifetime costs for this technology as the amount of existing thermal capacity which can be freed up is very project specific. As such only the build cost has been estimated, which is approximately half that of a quadrature booster.
	Rating/Capacity/Distance	It is important to note that this technology does not create additional thermal capacity, but maximises the use of existing capacity.
	Environmental Impact	It is usually necessary to extend a substation or create a new compound to accommodate this equipment. However, the environmental impact of this is unlikely to be significant if appropriate planning is carried out.
	Carbon Intensity	No significant oil content. Supported on steel structures located on several smaller foundations. May require extension of substation. Overall carbon intensity is expected to be low.
	Local Impact	Can be located on existing substations so minimal increased impact to local communities, or small compounds may need to be established. Overall the impact would not be expected to be significant.
	Technology Readiness	TRL7. Relatively recent technology based on established principles, with the first GB installation in 2021. There are now several examples in service and under development on the GB NETS.
	Technology Adaptability	Does not create additional capacity, is limited to making best use of existing capacity. Offers greater control as compared to other devices. Relatively small footprint. Modular systems available, which can be increased or decreased with relative ease, thus providing adaptability to changing system needs. Modular solutions can also be removed and redeployed elsewhere on the network if required. Offers additional system benefits such as phase balancing, stability, oscillation damping, avoidance of high transient voltages, and immunity to sub-synchronous resonance.
	Technology Resilience	Largely comparable to standard substation equipment, which can be susceptible to weather events due to being located outdoors. However, risk can be minimised through appropriate design measures.
	Programme	Solution can be deployed relatively quickly. Construction programme likely to be comparable to that of a standard substation extension. Procurement programme not expected to be significant. Modular construction offering standardised approach to design and assembly. However, limited pool of suppliers.

Table 5.6: Cost and non-cost characteristics – offshore technologies

Offshore Technologies – evaluated for 90, 180 and 275 km and high/medium/low rating unless otherwise stated		
275 kV HVAC submarine cable (offshore platform – onshore substation) <ul style="list-style-type: none"> ● Build: £373m - £2,973m ● Lifetime: £580m - £5,109m ● Lifetime £/km: £5m - £30m ● Lifetime £/MWkm: £9,046 - £14,779 ● Average Lifetime £/MWkm: £11,200 ● Data Source: public domain data 	Cost Commentary	<p>Suitable three-phase 275 kV cables have only recently become available; prior to this the maximum voltage was limited to 220 kV, restricting power transfer capacity on a single cable to <500 MW , thus other documentation in the public domain may, for example, consider the use of two 220 kV cables to facilitate a link of this capacity. As a result, the build cost per kilometre is less than what may have been considered previously, resulting in the break-even length, beyond which the alternative HVDC technology becomes more economic, increasing. Lifetime costs per MW km fall with increasing transmission distance, as some cost efficiencies are realised, although the impact is not significant. The data indicates that this technology is cost effective in comparison with HVDC for low power transfers, even at distances up to 275 km, due to the relatively high fixed costs of HVDC transmission. However, for transmission over such distances to be technically feasible, mid-point reactive compensation platforms will be required, and it may not always be possible to install these, which could preclude a viable a.c. solution. For high power transfers a.c. is only cost effective in comparison with HVDC over shorter distances.</p>
	Rating/Capacity/Distance	<p>This study considers the use of a single 275 kV a.c. cable providing 500 MW of capacity, which is consistent with proposals in the Electricity System Operator’s ‘Holistic Network Design’ (HND) for offshore electricity transmission in 2030. Circuit ratings in excess of ~500 MW require the use of multiple cables, significantly increasing build costs and with higher environmental impact. Suitable three-phase 275 kV cables have only recently become available; prior to this the maximum voltage was limited to 220 kV, restricting power transfer capacity on a single cable to <500 MW , thus other documentation in the public domain may, for example, consider the use of two 220 kV cables to facilitate a link of this capacity.</p> <p>In order to achieve high power transfers, multiple a.c. cable circuits would be required as compared to a HVDC solution which may still only require a single circuit.</p>
	Environmental Impact	<p>Impact similar to offshore HVDC. Whilst no need for converter stations, this could be offset by the need to construct multiple cable circuits to achieve the same rating, or the need for intermediate compensation platforms offshore. Moderate environmental impact due to installation of cable system offshore as well as requirement for foundations for any platforms with seabed impact.</p> <p>Environmental impacts are usually reduced to manageable levels through appropriate upfront planning and studies. Burial of cable on seabed will have a local environmental impact. Environmental impact at marine landings needs to be managed. Short onshore route length with similar environmental impact to that of UGC.</p> <p>There is an impact on the makeup of the ground both onshore and offshore for the life of the asset as a result of the buried equipment. In the event of a repair further excavations would be required, with disturbance to the seabed if repairs are offshore.</p>
	Carbon Intensity	<p>Embodied carbon content for the cable system will be similar to that for a direct buried UGC. Additional carbon content as a result of the lengthy cable route, and the associated offshore vessels.</p>

Local Impact	<p>Impact similar to that of offshore HVDC. Whilst no need for converter stations, this could be offset by the need to construct multiple cable circuits to achieve the same rating, or the need for intermediate compensation platforms offshore.</p> <p>Visual impact from the cable system is minimal following completion of installation.</p> <p>As majority of infrastructure is installed offshore the impact during construction is lower than that of onshore cables. Impact on fishing industry and other marine activities must be considered.</p>
Technology Readiness	<p>TRL9. Well-established technology in GB and worldwide for voltages up to 220kV a.c.</p> <p>In particular, there is substantial operational service history in GB as a result of the OFTO infrastructure.</p> <p>Whilst there is less experience of reactive compensation platforms, some examples are available in service.</p>
Technology Adaptability	<p>Suitable for use as part of a meshed network as well as point-to-point. Whilst the points of connection for each end of the cable are fixed, it is more straightforward to adjust these as compared to a HVDC system. The submarine cable route can be “micro-routed” around localised obstructions but generally follows a pre-defined cable corridor identified at an early stage of the project. It is generally not possible to increase the rating of a submarine cable system or adjust its operational voltage, or change it from a.c. to d.c. operation. Reactive compensation platform required to achieve a.c. cable of this length. It may not always be possible to accommodate such a platform, for example due to water depth, seabed conditions, or for environmental reasons.</p>
Technology Resilience	<p>Cables tend to be of significant length and statistically a longer cable will have a higher probability of failure.</p> <p>Installation and burial strategy of submarine cable can impact upon the resilience of the cable to external events such as dragging of ships’ anchors.</p> <p>In the event of a submarine cable fault, the system will be offline or at reduced capacity (often 50%). Whilst it is common to maintain a stock of spare cable and joints, repair times can still be lengthy with typical durations between 65 and 105 days considered.</p>
Programme	<p>Planning and consenting process can be of significant duration, including identification of offshore route and appropriate landing point.</p> <p>Lead-time on supply of cable can extend the programme due to linear manufacturing process and limited factories.</p> <p>Programme can be logistically challenging as a result of the need for offshore installation campaigns, which tend to be restricted to specific weather windows.</p> <p>Capacity and availability of installation vessels, support vessels, and suitably competent resource can provide programme constraints.</p> <p>Jointing, termination and testing, both onshore and offshore, requires specialist resource, with restricted availability providing a programme constraint.</p>
HVDC VSC Submarine Cable (offshore platform – onshore substation)	<p>Cost Commentary</p> <p>HVDC systems have a relatively high fixed cost due to the requirement for a.c./d.c. converter stations at each end of a link. These converter stations also introduce additional losses. Thus lifetime £/MWkm costs of such systems for low power transfers are relatively high and typically uneconomical in comparison with a.c. transmission. The lifetime cost reduces significantly with increases in both power transfer capacity and distance, making this a cost effective technology for high power transfers, even over relatively short distances. For the cases considered in this study, and considering a lifetime cost, we have established break-even distances (above which HVDC transmission is more</p>
<ul style="list-style-type: none"> ● Build: £514m - £2,078m ● Lifetime: £930m - £3,848m 	

<ul style="list-style-type: none"> ● Lifetime £/km: £5m - £37m ● Lifetime £/MWkm: £6,997 - £20,662 ● Average Lifetime £/MWkm: £12,900 ● Data Source: public domain data 	<p>economic than a.c.) of around 150 km for a high rating, 180 km for a medium rating, and 275 km for a low rating. Operation and maintenance costs are higher than an equivalent a.c. cable system.</p> <p>Rating/Capacity/Distance It is noted that these links are currently limited, technically, to a maximum power transfer capacity of ~2 GW with higher capacities requiring multiple links, thus significantly reducing cost efficiencies.</p>
<p>Environmental Impact</p>	<p>For high power transfers, the environmental impact resulting from cable installation is expected to be less than that of an a.c. solution, since an a.c. solution would require multiple circuits.</p> <p>Moderate environmental impact due to installation of cable system in a marine environment. Platforms would be restricted to a single offshore location, with no need for any intermediate stations, although there would be a seabed impact at these locations as a result of the foundations.</p> <p>Environmental impacts are usually reduced to manageable levels through appropriate upfront planning and studies.</p> <p>Burial of cable on seabed will have a local environmental impact.</p> <p>Environmental impact at marine landings needs to be managed.</p> <p>Short onshore route length with similar environmental impact to that of UGC.</p> <p>Impact as a result of the need to construct onshore/offshore converter stations.</p> <p>There is an impact on the makeup of the ground both onshore and offshore for the life of the asset as a result of the buried equipment. In the event of a repair further excavations would be required, with disturbance to the seabed if repairs are offshore.</p>
<p>Carbon Intensity</p>	<p>Embodied carbon content for the cable system will be similar to that for UGC.</p> <p>Additional carbon content as a result of the lengthy cable route and the offshore vessels.</p> <p>Additional carbon content as a result of the need to construct converter stations.</p>
<p>Local Impact</p>	<p>For low-rated projects, the impact of onshore construction works on local communities may be greater than an a.c. solution as the converter station infrastructure would likely be larger.</p> <p>Visual impact from the cable system is minimal following completion of installation.</p> <p>As majority of infrastructure is installed offshore, the impact during construction is lower than that of onshore cable systems.</p> <p>Impact, both visually and during construction, from onshore converter stations.</p> <p>Visual impact of offshore platforms usually minimal as they are located some distance offshore.</p> <p>Impact on fishing industry and other marine activities must be considered.</p>
<p>Technology Readiness</p>	<p>TRL9. Technology has matured over the past decade to be a reliable option for point-to-point solutions. Several systems in operation in GB. Whilst systems to date have used lower voltage levels (mainly up to 320kV), the industry is converging on the use of 525kV solutions, with many such systems planned to be installed in GB and globally in the near future.</p>
<p>Technology Adaptability</p>	<p>Point-to-point solution which cannot “tap in” to other stations along the route without additional technical complexity and significant additional cost due to the need for a converter station. The submarine cable route can be “micro-routed” around localised obstructions but generally follows a pre-defined cable corridor identified at an early stage of the project. It is generally not possible to increase the rating of a point to point HVDC link. The link can operate in</p>

	<p>both directions and can change loading to meet system needs. Depending on the design, a HVDC link can provide other system benefits such as black start capability, frequency control, and stability services. Capable of interconnecting asynchronous systems.</p>
<p>Technology Resilience</p>	<p>Converter stations can be susceptible to weather events, although this can be minimised through appropriate design measures. Cables tend to be of significant length and statistically a longer cable will have a higher probability of failure. Installation and burial strategy of submarine cable can impact upon resilience. In the event of failure to a critical component, such as converter transformers, repair times can be lengthy and system will be offline or at reduced capacity (often 50%). However, it is common practice to provide a spare of such components at the converter station location to reduce repair times accordingly.</p> <p>In the event of a submarine cable fault then the system will be offline or at reduced capacity (often 50%). Whilst it is common to maintain a stock of spare cable and joints, repair times can still be lengthy with typical durations between 65 and 105 days considered.</p>
	<p>Programme</p> <p>Planning and consenting process can be of significant duration, including identification of offshore route and appropriate landing point. Design and construction of converter stations, both onshore and offshore, can be lengthy. Lead time on supply of cable can extend the programme due to linear manufacturing process and limited factories. Programme can be logistically challenging, as a result of the need for offshore installation campaigns, which tend to be restricted to specific weather windows.</p> <p>Capacity and availability of installation vessels, support vessels, and suitably competent resource can provide programme constraints.</p> <p>Jointing, termination and testing, both onshore and offshore, requires specialist resource, with restricted availability providing a programme constraint.</p>
<p>Embedded HVDC VSC Submarine Cable (linking two onshore locations, 2 GW)</p> <ul style="list-style-type: none"> ● Build: £821m - £1,102m ● Lifetime: £1,694m - £2,108m ● Lifetime £/km: £8m - £19m ● Lifetime £/MWkm: £3,830 - £9,410 ● Average Lifetime £/MWkm: £6,170 ● Data Source: public domain data 	<p>Cost Commentary</p> <p>The data indicates that the cost for such HVDC embedded links is around half that of an onshore – offshore HVDC link. This clearly demonstrates the additional cost associated with locating assets offshore which is as a result of several factors, such as the need for an offshore platform and the cost and constraints associated with working offshore. As previously discussed, due to the high fixed costs of the converters, the lifetime costs (in £/MWkm) initially fall significantly as the transmission distance increases, but level off as the cable starts to dominate the build cost.</p> <p>Rating/Capacity/Distance</p> <p>It is technically feasible to establish a link between two onshore locations by using an offshore cable. These connections are referred to as “embedded links” and there is an existing example in Britain, the Western Link, connecting Hunterston in Ayrshire with Flintshire Bridge in Cheshire. By diverting power flows away from the onshore network, an embedded link can be effective at enhancing the overall network capacity. Several more projects of this nature have been recommended in the HND and are currently under development.</p> <p>Due to the limited power transfer capacity of subsea a.c. cables and technical limitations on their length, the most effective technology to implement an embedded link is HVDC. This also has the advantage that power flows through the link are controllable, so that load sharing with existing transmission assets is not a design issue. As the converters at each end of the embedded link are connected to the a.c. transmission network, they can utilise either ‘classic’ LCC converter technology (based on thyristor switches) or the more recent VSC converters. Whilst Western Link uses LCC, it is anticipated that the next generation of projects will utilise VSC converters.</p>

		We have only considered a 2GW solution as part of this study, based on the technical capability of VSC converters and HVDC cable systems.
	Environmental Impact	Similar to HVDC VSC submarine cable, but increased onshore impact due to a second onshore converter station and associated onshore cable route. Conversely, reduced impact on marine environment as no offshore platform is required.
	Carbon Intensity	Similar to HVDC VSC Submarine Cable. Whilst no offshore platform is required, reducing the quantity of steel, a conventional onshore substation is required with associated carbon content.
	Local Impact	Similar to HVDC VSC submarine cable, but increased onshore impact due to a second onshore converter station and associated onshore cable route. Conversely, reduced impact on marine activities as no offshore platform is required. Impact on fishing industry and other marine activities must be considered.
	Technology Readiness	TRL9. Established technology, as per HVDC VSC Submarine Cable
	Technology Adaptability	Adaptability considerations as per HVDC VSC Submarine Cable
	Technology Resilience	Network resilience and repair times are similar to that of an a.c. cable.
	Programme	Similar considerations to HVDC submarine cable onshore-offshore solution. Planning and consenting process can be of significant duration, including identification of offshore route and appropriate landing points. Design and construction of converter stations can be lengthy. Lead time on supply of cable can extend the programme due to linear manufacturing process and limited factories. Programme can be logistically challenging, as a result of the need for offshore installation campaigns, which tend to be restricted to specific weather windows. Capacity and availability of installation vessels, support vessels, and suitably competent resource can provide programme constraints. Jointing, termination and testing, both onshore and offshore, requires specialist resource, with restricted availability providing a programme constraint.
Multi-terminal HVDC (2GW, 2x180 km circuits, two onshore, one offshore)	Cost Commentary	Whilst this solution is more expensive than a conventional point-to-point link, it can provide additional functionality. Not readily comparable with other solutions. Cost is greater than a single point-to-point link, but more cost effective than constructing two separate links due to the need for only three converter stations.
<ul style="list-style-type: none"> ● Build: £2,549m ● Lifetime: £4,482m ● Lifetime £/km: £24.90m ● Lifetime £/MWkm: £12,500 	Rating/Capacity/Distance	We have considered an offshore platform which may be connecting 2 GW of wind generation, which can then be transmitted to two separate onshore locations. This could serve as both an onshore-offshore point to point link, as well as providing reinforcement to the onshore network.
	Environmental Impact	Additional cable system and converter station as compared to point to point HVDC application. Impact as a result of the need to construct onshore/offshore converter stations. Other areas similar to HVDC VSC solution.

<ul style="list-style-type: none"> Data source: indicative estimate based on derivation from public domain information 	Carbon Intensity	Increased embodied carbon content as compared to point to point HVDC application as a result of additional cable circuit and converter station. Other points as per HVDC VSC.
	Local Impact	Similar to standard HVDC but increased impact by virtue of additional cable circuit and converter station.
	Technology Readiness	TRL9 for radial multi-terminal, TRL4 for meshed multi-terminal Not yet a fully developed technology. Lack of GB operational experience, although one such system now exists with several others planned. Regulatory environment still being defined for some applications.
	Technology Adaptability	Similar to Offshore HVDC, although due to the proprietary nature of the technology, a whole-system solution will likely be procured from a single OEM, although vendor-agnostic solutions are being developed. Offers the ability to connect multiple locations using a single HVDC system without the need for two converter stations at each location. For example, could connect an offshore platform to two onshore locations, potentially located in separate countries. Thus acting as an “embedded link” or “interconnector” as well as offshore transmission infrastructure. Potential for existing HVDC systems to be extended to multi-terminal.
	Technology Resilience	Similar to Offshore HVDC. Additional cable circuit and converter station may statistically give rise to a greater risk of faults.
	Programme	Similar to Offshore HVDC. Consenting and manufacturing programmes may be extended as compared to a point to point system as a result of the additional cable circuit and converter station. May be possible to undertake construction of additional cable circuit and converter station in parallel for some parts of the construction programme. Commissioning programme likely to be extended as compared to point to point HVDC system.

The 2012 study also considered the use of gas-insulated line. For this study we have not undertaken a cost assessment for gas-insulated line. The reason for this is that the TOs have indicated that they have no plans to use this technology outside a substation environment, and that GIL contains a large quantity of SF₆ gas, which the industry is trying to move away from due to its extremely high global warming potential. Neither the TOs nor the supply chain were able to provide any cost data in respect of this technology.

5.1 Comparison With 2012 Report

It is not possible to undertake a direct comparison between this report and the 2012 report, as some of the assumptions underpinning the calculations are different, and there are some differences in the technologies evaluated. However, it is possible to undertake a generic review of the two reports to gain an understanding as to any changes in cost differentials between 2012 and 2023 (base year for pricing purposes). The main technologies which can be compared, and the different cases considered, are as follows:

Table 5.7: 2012 cases vs 2023 cases

Technology	2012 Cases	2023 Cases
Overhead Line (OHL)	Distance: 3 km, 15 km, 75 km	Distance: 3 km, 15 km, 75 km
Underground Cable – Direct Buried (UGC)	Ratings: <ul style="list-style-type: none"> ● High: 6,930 MVA 	Ratings: <ul style="list-style-type: none"> ● High: 7,482 MW
Underground Cable – Tunnel (UGC-T)	<ul style="list-style-type: none"> ● Medium: 6,380 MVA ● Low: 3,190 MVA 	<ul style="list-style-type: none"> ● Medium: 4,988 MW ● Low: 2,494 MW
HVDC onshore to onshore	Distance: 75 km Ratings: 3,000 MW, 6,000 MW	Distance: 90 km, 180 km, 275 km Ratings: 2,000 MW

Table 5.8 provides a comparison of the build cost percentage for the onshore technologies between the 2012 and current reports (using 2023 price base). The percentages are calculated by dividing the total build cost by the lifetime cost. Operating cost percentages are thus 100% minus the figures below.

Table 5.8: Build cost as a percentage of lifetime cost for 2012 and 2023

Rating:	3 km			15 km			75 km		
	L	M	H	L	M	H	L	M	H
2012									
OHL	63%	42%	47%	61%	41%	46%	60%	39%	45%
UGC	93%	91%	92%	91%	90%	90%	89%	89%	89%
UGC-T	97%	95%	95%	95%	93%	93%	94%	92%	91%
2023									
OHL	69%	51%	44%	65%	47%	39%	64%	44%	37%
UGC	88%	88%	87%	88%	87%	85%	88%	87%	86%
UGC-T	91%	91%	90%	91%	90%	89%	91%	90%	89%

From the table above, we can observe the following:

- In both 2012 and 2023, we can see that underground cables have a proportionally lower amount of operating costs as compared to overhead lines, with tunnels showing a further reduction. This is to be expected since, for technical reasons, cable systems must be designed with a much lower loss factor than is economically justified for an OHL.
- In both years, the figures are of a similar order of magnitude, although, in general, operating costs make up a larger percentage in 2023 as compared to 2012. The exceptions to this are the low and medium-rated overhead lines, where operating costs make up a greater

percentage in the 2012 study. The reasons for this are the different ratings which have been used and the different assumptions for calculating losses.

For HVDC, we have considered the 90 km 2023 case, where the build cost is 47% of the lifetime cost. In the 2012 study this was 74%, however, the rating and technology configuration were fundamentally different and cannot be compared like for like.

Table 5.9: 2012 and 2023 Cost Ratios

Rating:	3 km			15 km			75 km		
	L	M	H	L	M	H	L	M	H
2012									
UGC/OHL Build costs	7.91	11.66	11.02	6.74	10.33	9.79	6.86	10.60	10.11
UGC/OHL Operating costs	1.04	0.79	0.91	1.07	0.80	0.91	1.19	0.88	1.00
UGC/OHL lifetime power transfer costs	5.35	5.35	5.69	4.55	4.73	5.00	4.59	4.70	5.07
UGC-T/UGC Build Costs	2.77	1.95	1.85	2.22	1.58	1.50	2.10	1.51	1.42
UGC-T/UGC Operating Costs	1.18	1.10	1.10	1.14	1.09	1.09	1.13	1.08	1.07
UGC-T/UGC Lifetime Power Transfer Costs	2.66	1.88	1.79	2.12	1.53	1.46	2.00	1.46	1.38
2023									
UGC/OHL Build costs	5.73	8.05	8.52	6.27	8.74	9.25	6.35	9.28	9.71
UGC/OHL Operating costs	1.69	1.19	0.96	1.63	1.13	1.05	1.59	1.10	0.89
UGC/OHL lifetime power transfer costs	4.49	4.71	4.27	4.67	4.67	4.22	4.63	4.68	4.12
UGC-T/UGC Build Costs	3.79	2.92	2.15	3.13	2.52	1.92	3.07	2.54	1.89
UGC-T/UGC Operating Costs	2.81	2.17	1.73	2.35	1.91	1.34	2.28	1.89	1.54
UGC-T/UGC Lifetime Power Transfer Costs	3.68	2.83	2.10	3.03	2.44	1.83	2.98	2.45	1.84

From the table above, we can observe the following:

- The 2012 study indicated that the build cost of an underground cable is seven to twelve times that of an overhead line, and the build cost of a cable in a tunnel being two to three times the cost of an underground cable.
- When lifetime power transfer costs are considered, the cost of an underground cable was between five and six times the cost of an overhead line, with a tunnel being one and half to three times higher.
- In 2023, the build cost of an underground cable as compared to an overhead line is indicated as being between six and ten times that of an overhead line, and the build cost of a tunnel being between around two to four times that of an underground cable.

- When lifetime power transfer costs are considered, the cost of an underground cable in 2023 is indicated to be between four and five times that of an overhead line, with a tunnel being around two to four times higher

We conclude that the cost ratios between the key onshore technologies in 2023 are of a similar order of magnitude to those from the 2012 report, and the range is very comparable when lifetime power transfer costs are considered. When considering only build costs, the ratio has reduced slightly, as compared to 2012, possibly as the low/medium/high ratings we have considered were selected to optimise the cost efficiency of cables. However, the cost of constructing underground cable circuits remains considerably higher than that of overhead lines.

In terms of HVDC technology, the 2012 report compared the build cost and lifetime cost of an embedded 3,000 MW HVDC solution with that of a low-rated overhead line for a 75 km route length. It concluded that the ratio of lifetime cost was 7.3 and of build cost was 9. Whilst we have not calculated a 75 km case in 2023, we have compared the 90 km scenario and the ratios are 7.8 (lifetime cost) and 5.7 (build cost). As discussed previously, it is difficult to draw a meaningful comparison between these cases due to the different configurations which have been studied.

6 Main Findings

This document provides an update to the electricity transmission cost study originally produced in 2012, reflecting developments in a variety of areas, including technologies and costs. In particular, this report includes increased analysis of offshore transmission technologies as their use is set to increase significantly. For this revision, we have expanded the analysis to also consider a number of factors in addition to cost and rating, termed the “non-cost characteristics”.

Main Onshore Transmission Technologies

The 2012 study concluded that overhead lines were the cheapest technology for a given route length or circuit capacity, and indicated that the cost of direct-buried underground cables was around five to six times more expensive. In this updated study we conclude that overhead lines remain the cheapest transmission technology, with a lifetime power transfer cost for the cases we have studied ranging from £1,012/MWkm to £1,492/MWkm. In comparison, direct-buried underground cables are around four to five times more expensive, with a lifetime power transfer cost ranging between £4,429/MWkm and £6,700/MWkm.

The 2012 study also examined the use of tunnels and concluded that the lifetime cost of a cable in a tunnel was between 1.4 and 2.7 times that of a direct-buried underground cable. In this updated study we have found the lifetime cost of a cable in a tunnel to be between 1.8 and 3.7 times that of a direct-buried underground cable, with a lifetime power transfer cost ranging between £8,145/MWkm and £24,658/MWkm.

Considering the non-cost characteristics, we observe the following:

- Both overhead lines and underground cable technologies are well established, having been used for many decades with technological advances continuing to be implemented. However, it is technically challenging for an underground cable circuit to match the power transfer capability of an overhead line.
- Underground cables will require reactive compensation systems to be installed along the route, and there is a physical limitation as to the distance which can be covered without an intermediate station.
- Whilst overhead lines are exposed to the elements, their design is such that they are reasonably resilient. In the event of a fault, this can usually be identified and repaired much more quickly than an underground cable.
- However, overhead lines have a greater visual impact as compared to underground cables and so may not be suitable for installation in some locations.
- Underground cables are considered to have a greater environmental impact during construction, as a result of the need for largescale excavations.
- The material supply and construction programme for an overhead line is likely to be quicker than that of an underground cable, with the construction programme for a tunnel taking longer still. However, overhead lines can face significant consenting challenges leading to lengthy pre-construction programmes.
- The lifetime carbon intensity of underground cables and overhead lines is considered comparable, although this would be increased in the event of installation in a tunnel.

The 2012 study also examined the use of gas-insulated line using sulphur-hexafluoride (SF₆), both direct-buried and in tunnels. For this study, we have not provided a cost estimate as there is no expectation for it to be used outside of a substation environment within the timeframe of this study. Further, SF₆ gas has a high global warming potential and, as such, the transmission

industry is seeking to move away from its use. Whilst alternative gases are under development, we are not aware of these being available for use outside a substation environment at the present time.

Main Offshore Transmission Technologies

Both alternating current (a.c.) and high voltage direct current (HVDC) solutions are expected to be deployed going forward. Whilst the use of HVDC was considered in the 2012 report, the technologies, ratings and circuit lengths which were studied are not comparable to those we have considered in this report.

We have studied the use of 275 kV a.c. submarine cables and HVDC technology for different scenarios. HVDC systems have a high upfront cost associated with the converter stations, which usually renders them uneconomic for short distances or low power transfers. A.c. solutions will require multiple circuits for higher power transfers and need intermediate reactive compensation platforms for longer distances. Thus the higher the power requirement, and the greater the distance, the more economic it is to use a HVDC option. Considering only build cost, and based on the assumptions of our study, for 2,000 MW the break-even distance (above which HVDC becomes more economic) is around 100 km, for 1,000 MW it is around 140 km, and for 500 MW it is around 240 km. When lifetime cost in £/MWkm is considered, the breakeven distance is extended slightly to around 150 km for 2,000 MW, 180 km for 1,000 MW, and 275 km for 500 MW.

The technologies are comparable in respect of the non-cost characteristics with only the following key areas of differentiation:

- HVDC systems are judged to have a slightly higher carbon intensity, primarily as a result of the need to construct converter stations at each end.
- HVDC systems are scored slightly lower in respect of resilience as a result of the complexities of HVDC converter stations. Further, in the event of multiple a.c. circuits being required, if there is a fault on one circuit then power flows can be maintained in the others, which may not be the case with HVDC.

As well as facilitating the connection of offshore renewable energy, or interconnection between countries, offshore electricity transmission can also be used to reinforce the onshore network. For example, there are several new circuits proposed from Scotland to different areas in England using circuits routed offshore but with both converter stations located onshore. These circuits have different functionality as compared to onshore networks and are used by the system operator in a different way, and hence cannot be directly compared with an onshore alternating current underground cable or overhead line.

However, they can be used to assess the magnitude of cost increases for locating equipment offshore. As compared to a solution of same rating and length, the build costs for a solution with one converter station onshore and one offshore are between 1.9 and 2.2 times higher than locating both converter stations onshore, with lifetime costs being around 1.7 to 1.9 times higher. It is evident that locating substations and converter stations offshore is a more expensive solution. Whilst it is unavoidable in some instances, such as for the connection of offshore windfarms to the onshore transmission system, the cost difference between an onshore and offshore substation is significant and unlikely to be justified where other solutions exist.

Multi-terminal solutions are also a possibility, with one such example having recently entered operation in GB and others in development. These could be used to connect multiple locations using a single HVDC system, such as connecting an offshore platform to two onshore locations. Whilst this solution is more expensive than a single point to point link, it is more cost effective than constructing two separate point to point links.

Alternative Technologies

This study considers a number of additional technologies, as compared to the 2012 study which are summarised in the following table:

Table 6.1: Additional Onshore Technologies Studied

Technology	Description
Pressurised Air Cables	Emerging technology, similar to gas-insulated line but using compressed air and with more flexible joints. Application is so far limited to test environments and small-scale demonstrations, all outside GB, and thus it has no operational service history. Availability of data is limited and the cost-certainty of our estimates is comparatively low. Level of power transfer using a single conductor per phase, accommodated in a single trench, is similar to that of a medium-rated cable which uses two conductors per phase. Thus the lifetime cost is around 70-80% that of the equivalently rated direct-buried cable, although costs are highly indicative. However, as a result of the industry's move away from the use of SF ₆ gas, it is likely that pressurised air cables or other similar technologies using alternative gasses will mature in the near term and could be deployable in the mid term.
Superconducting Cables	This is another emerging technology, although it is more mature than pressurised air cables and has seen significant development in recent years, with some commercial applications now in service, although all outside GB and limited to up to 132 kV. Can achieve similar power transfers at 132 kV as a 400 kV low-rated, direct-buried cable. We have found lifetime power transfer cost of a superconducting cable to range between £7,291/MWkm and £8,424/MWkm - around 1.3 to 1.4 times that of an equivalently rated underground cable, but only around 35-50% that of a cable in a tunnel, although these costs are highly indicative. Given that such power transfers are possible at 132 kV using this technology, it could introduce other benefits, particularly in areas where space constraints exist, for example by removing the need for additional infrastructure such as transformers, switchgear and associated substation extensions.
Reconductoring	Existing overhead lines can have conductors replaced, with a "high-temperature low sag" option, achieving limited, albeit useful, capacity increases. Effective solution which can be deployed relatively quickly with minimal impact due to reusing existing assets. Amount of additional transmission capacity which can be achieved is limited. The case we have considered examines upgrading a 75 km length of medium-rated overhead line. Due to re-use of existing assets, the build cost is low, but because of the limited increase in power transfer capacity which can be achieved, the lifetime power transfer cost of £1,981/MWkm is slightly higher than that of the other overhead line systems, although still comfortably less than equivalent underground cable circuit.
Use of T-Pylons	Historically, steel lattice towers have been used but other types are available. Most recently, National Grid has used the T-pylon design, which is a monopile type structure. These are not suitable for use in all terrains but, depending on the context, they can sometimes be considered to have an improved visual appearance as compared to steel lattice designs. However, these have a higher up-front cost, are less adaptable to different terrains, and have limited in-service experience. As a result, there is a lack of available data for costs. We have evaluated a single case of a medium-rating overhead line over 15 km and 75 km route lengths. The build cost is approximately 2 to 2.5 times that of an equivalently-rated conventional overhead line, and the lifetime power transfer cost of £1,731/MWkm is around 1.6 to 1.7 times that of a conventional overhead line. However, this is still significantly less than an equivalent underground cable at around 0.35 to 0.37 times the cost.

There are also several options available for enhancing existing transmission capacity and our study considers both static series synchronous compensators (SSSC), which are a relatively recent technology, and quadrature boosters, which have been used historically. These technologies control power flows to make best use of existing transmission capacity, and thus there is a limit to the amount of increased capacity which can be achieved, which it is difficult to quantify as this is highly situation dependent. However, we have estimated the capital cost of a typical SSSC installation as £16m-18m whereas a quadrature booster is estimated to be in the region of £35m-£40m.

Long-Distance Onshore Transmission

We have considered both a.c. and HVDC options for long distance onshore transmission over a distance of 700 km. Although they have been used in other countries, such solutions have not been used to date in GB. For an underground cable solution we have examined a 2 GW HVDC option, a system which is currently being deployed in other countries in Europe. We have estimated a build cost of £1,867m and a lifetime power transfer cost of £2,270/MWkm. For greater power transfers, an 8 GW HVDC option using an overhead line has been considered. This has a much higher build cost, estimated at £4,059m, but an improved lifetime power transfer cost of £1,679/MWkm.

We have also studied an alternating current (a.c.) overhead line solution, operating at 765 kV with a build cost of £1,925m and a lifetime power transfer cost of £883/MWkm. Whilst these appear to be economical solutions, their functionality is different as compared to conventional overhead line or underground cable systems, and thus a direct comparison should not be made. In particular the 2 GW HVDC and 765 kV a.c. solutions are single circuits, and thus a fault on one of the conductors would result in total loss of transmission capacity, whilst for the 8 GW HVDC solution a 50% loss of transmission capacity would occur.

Further, in particular for the 8 GW options, deciding to introduce such systems would require extensive preparation and master planning and would introduce fundamental changes to the way in which the system is operated. The TOs do not currently have specifications, design standards or other documentation for operating these systems. It is also likely that construction of routes of this length would face significant challenges for a number of reasons including from a planning perspective, obtaining the necessary land ownership rights, and avoiding obstacles such as urban areas and existing infrastructure. It is therefore not considered as a realistic technology for deployment within the GB network in the medium term.

Supply Chain Findings

At the time of writing, there is considerable price volatility, particularly in Europe but also globally, with increasing raw material prices and supply chain constraints. Energy costs are high and have contributed to higher inflation, higher costs of living in many countries, increase in labour costs, along with variable exchange rates. As a result, there is currently significant price uncertainty within the supply chain.

The national and global drive towards Net Zero has led to a large amount of activity ongoing in the electricity transmission sector at the present time, with a high demand placed on a limited supply chain. This, combined with the price volatility, has led to limited engagement from the supply chain in respect of data provision for this study.

Final Summary

When reading this report, it is important to keep the following points in mind:

- There are a number of factors which may lead to one technology being chosen over another, for reasons other than cost or rating.
- Costs and benefits of different technologies depend heavily on the specifics of individual projects, their locations, and the outcomes desired from them. This report provides indicative costs that need to be read in the context of these variables.

This work is intended to give a broad context for assessing relative costs of different technology choices (and is not intended to be used as a basis for making choices for a particular application at a point in time - that would need specific study). Given the scale of investment expected, both globally and in GB, we would also expect some evolution of both technology and costs over time, something to be taken into account if reading this work at some point in the future.

Appendices

A.	Terms of Reference	151
B.	Consultant Team Members	162
C.	Costing Methodology	163
D.	Overhead Lines	177
E.	Underground and Submarine Cables	205
F.	Tunnels	239
G.	High Voltage Direct Current	257
H.	Alternative Technologies	269
I.	Losses	289
J.	Environmental	297
K.	Carbon	306
L.	Bibliography	323
M.	Letter from Project Board	328
N.	List of Organisations Approached	330
O.	Abbreviations and Acronyms	333

A. Terms of Reference

Mott MacDonald has been assigned to update the Electricity Transmission Cost Study (<https://www.theiet.org/media/9376/electricity-transmission-costing-study.pdf>) which was originally produced by Parsons Brinckerhoff (PB) in 2012. In producing that document PB developed a set of Terms of Reference (ToR) which were agreed with the Project Board at an early stage. This technical note provides an update to those ToR, which we are seeking to agree with the IET Project Board directing the updating as being suitable for undertaking our assignment.

A.1 Background

In Great Britain (GB) the electricity industry is regulated by Ofgem, an independent regulatory body charged with protecting the interests of consumers. Ofgem issue licenses to different companies to operate the GB electricity and gas transmission and distribution systems. The GB electricity system is split into Transmission – in England & Wales generally 275 kV and 400 kV networks along with offshore assets (≥ 132 kV), whilst Scotland also includes a proportion of 132 kV assets; and Distribution – generally 132 kV down to the low voltage supply entering domestic properties.

The overall GB transmission system is operated by a single entity called National Grid Electricity System Operator (NG ESO). The responsibility of this company is to plan the system and to operate it in real time, matching supply and demand and maintaining statutory voltage and frequency limits. As part of its planning responsibilities, NG ESO is responsible for managing applications for load or generation connections to the National Electricity Transmission System (NETS).

The NETS comprises both onshore and offshore transmission networks. The onshore transmission networks are owned by National Grid Electricity Transmission plc (NGET) in England and Wales, SP Transmission plc (SPT, a subsidiary of SP Energy Networks, or SPEN) in south and central Scotland and Scottish Hydro Electric Transmission plc (SHE Transmission or SHET, part of Scottish and Southern Electricity Networks, or SSEN) in the north of Scotland. These form the three GB regional Transmission Owners (TOs).

An overview of the UK and Ireland onshore transmission system ownership is given in Figure A.1.

Figure A.1: GB and Island of Ireland Transmission Owners, 2024

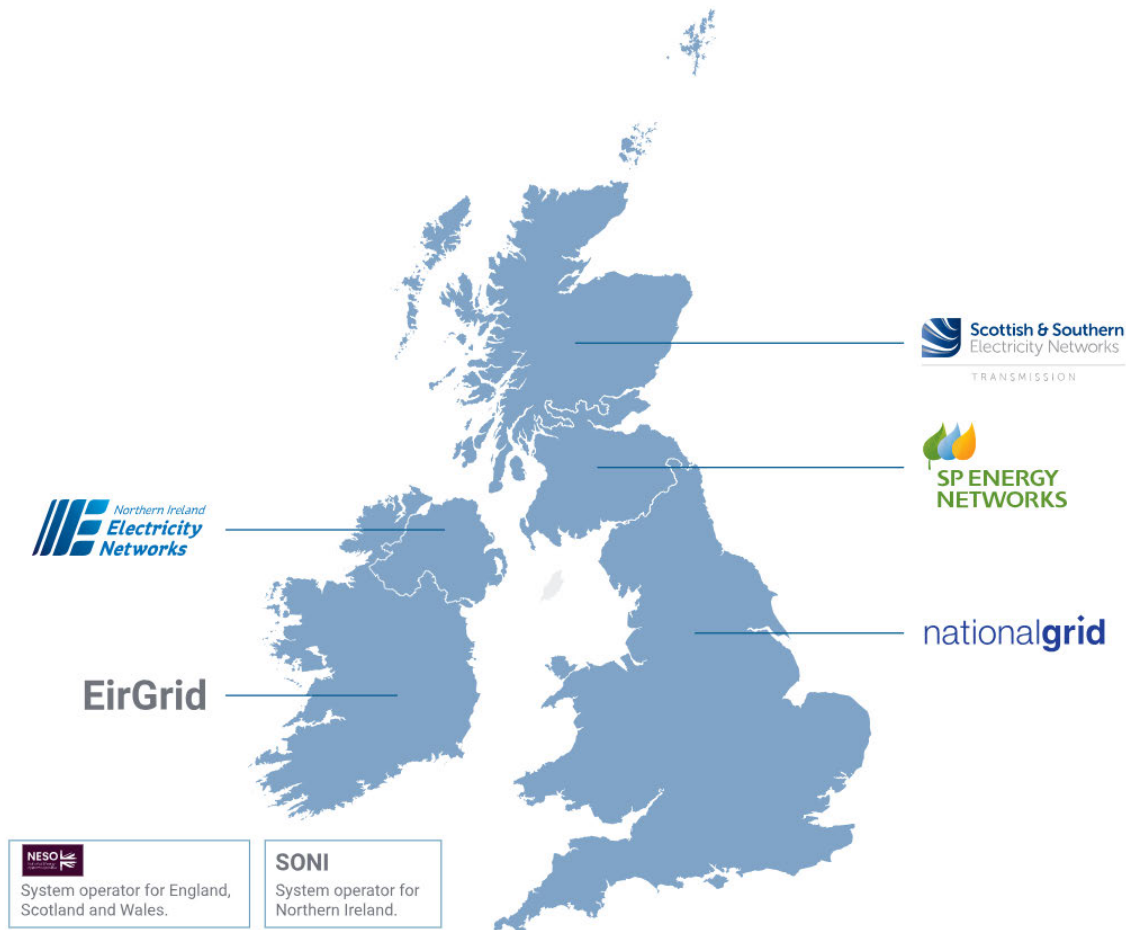

Source: “Who’s my Network Operator?”, Energy Networks Association, 2024. Available: <https://www.energynetworks.org/customers/find-my-network-operator>

The TOs must invest heavily over the coming years to maintain and extend the NETS and facilitate the country’s net-zero ambitions. At the time of writing this report, an energy transition is in progress with rapid growth of renewable generation sources and interconnectors to other nearby countries. This can result in the need to extend or reinforce the existing transmission system, including increasing the transfer capacity from sources of generation, to load centres. As well as significant upgrades to, and expansion of, Alternating Current (a.c.) infrastructure this has also led to an increase in installation of High Voltage Direct Current (HVDC) infrastructure offshore. NG ESO has developed a “Holistic Network Design” (HND, <https://www.nationalgrideso.com/document/262681/download>, July 2022) which considers both the onshore and offshore new infrastructure and reinforcement which is expected to be required to achieve the country’s net-zero ambitions. This provides a reasonable view as to the technologies which can reasonably be expected to be employed on the GB NETS in the near-to mid-term and, along with our professional knowledge and experience, has informed our opinion as to which technologies should be considered as part of this study as described in Section A.3.

The original version of the Electricity Transmission Cost Study was produced to provide an independent reference document in respect of several electricity transmission infrastructure schemes which were passing through the planning approvals process, and which had been challenged by Members of Parliament (MPs), members of the public, and campaign groups. Areas which, in particular, were challenged at the time included the costs that the project team

had put forward for underground and subsea cabling as potential alternatives to overhead line proposals. The primary objective of the 2012 report was to provide an authoritative view on the comparative costs of undergrounding and subsea cabling versus overhead power lines. Whilst this remains one of the objectives of the current study, this update also considers other factors which must be taken into account when considering such options in the current climate, and also introduces a number of new technology areas.

It is recognised that the extent by which the costs of one transmission technology are greater or less than those of another can vary considerably according to the specific circumstances of any particular project. Nevertheless, an independent and authoritative report should provide a useful point of reference against which to consider estimates for particular schemes and help inform public debate and decision-making on proposals for these and other electricity network projects.

A.2 Introduction

The primary purpose of the project is the production of an evidence-based, objective engineering assessment of credible options for GB implementation of additional or replacement electricity transmission capacity based on available technologies which are considered as viable for deployment within the GB NETS, including cost ranges and any wider implications including environmental.

The original report, completed in 2012, provided an authoritative analysis of the comparative costs of different transmission technologies and factors that influence those costs. Whilst much of this work remains relevant, it has been recognised that substantial extensions to the transmission network are planned as part of the 'pathway to 2030' initiative to connect new offshore wind generation and that it would be appropriate to review and update this report. Further, the update provides an opportunity to reflect technology developments, cost evolutions, further implementation experience, and potential new operational demands as well as presenting new comparative data on areas such as carbon footprint and environmental impact.

The 2012 work was overseen by a Project Board established by The Institution of Engineering and Technology (IET) and this approach has been taken again in producing this latest iteration of the report. The IET will provide quality assurance of the report and will ultimately judge whether it fulfils its intended function and is fit to be published. The objective of this arrangement is to demonstrate that the conclusions of the study are objectively based, independent, and not influenced by the TOs.

A.3 Scope, Assumptions and Exclusions

The TOs operate a large number of different types of assets, primarily ranging from 132 kV to 400 kV a.c. It would not be possible within the bounds of this study to produce a typical costing for each of those, and therefore a range of technologies have been chosen for study, based on the following considerations:

- Technologies studied in 2012 report.
- Review of the HND to form a view as to the technologies that NG ESO expects to be employed within the next 10-15 years.
- Our knowledge, experience and professional judgement as to the types of technologies likely to be seen in the next 10-15 years.
- Discussions with the Project Board and TO Stakeholders in respect of our proposed areas for study.

As a result we have divided the technologies which will be studied into different categories as explained in Table A.1, Table A.2, Table A.3 and Table A.4 provide details of what is included in

the scope, and Table A.5 notes specific exclusions. The tables include identification of what was included in the 2012 report, for ease of comparison.

Table A.1: Technology Categories

Category	Description
Comparable Onshore Technologies	<ul style="list-style-type: none"> ● Transmission networks have historically been formed of a 'gridiron' of alternating current (a.c.) transmission lines. Conventionally, a requirement for an increase in capacity is satisfied by constructing new links in the 'grid', and such interventions form a significant part of the HND proposals. ● The technologies considered are those suitable for constructing new passive point-to-point a.c. links in the grid which do not provide dynamic control functionality. ● These technologies would include, for example, overhead line and underground cable circuits with similar ratings which can provide similar functionality and be compared on a like-for-like basis in different situations.
Comparable Offshore Technologies	<ul style="list-style-type: none"> ● The HND is driven by an expected significant growth in offshore wind generation and therefore includes a large quantity of offshore assets to allow for connection of this generation capacity to the onshore network. Such assets would typically comprise of either a.c. or d.c. submarine cables, along with offshore substations. ● In addition, offshore assets are also to be installed in order to provide "embedded links", primarily to provide high-capacity long distance connections between different parts of the NETS, thus bypassing constrained areas of the onshore transmission network.
Alternative Technologies	<ul style="list-style-type: none"> ● The natural power flows through the grid can be modified to make better use of the capacity of the existing passive a.c. transmission lines. This can allow an increase in network capacity without providing new links. The technologies considered are typically those that provide a level of dynamic control of power flows such as quadrature boosters or static series synchronous compensators. In general, whilst the effects of these technologies on network capacity can be quantified, they are not typically readily generalisable or comparable across different contexts and need to be specifically assessed for each project. ● There are also certain technologies which could be employed by TOs in specific circumstances, for example reconductoring of overhead lines to increase the rating of a circuit, or use of superconductors, or use of multi-terminal HVDC systems. ● For these areas we will provide a typical example cost, along with a description of the circumstances where it may be employed, and a description of the benefits which it may provide. ● In general, it is difficult to compare these technologies on a like-for-like basis either with each other, or with conventional reinforcement technologies. In some cases a comparison against a specific case may be possible.

Table A.2: Comparable Onshore Technologies Scope

Description	Included in 2012 Study?	Included in Current Study?	Mott MacDonald Comments
Onshore:			
400 kV Overhead Line	Y	Y	<ul style="list-style-type: none"> A series of typical lengths and ratings will be established, and a costing produced for each.
400 kV Underground Cable – Direct Buried	Y	Y	<ul style="list-style-type: none"> Assumed that in all instances these are double circuit installations. Sensitivity analysis to be provided in respect to ducted cable installation.
400 kV Underground Cable – in Tunnel	Y	Y	

Table A.3: Comparable Offshore Technologies Scope

Description	Included in 2012 Study?	Included in Current Study?	Mott MacDonald Comments
Offshore:			
HVDC – Current Sourced Converter (CSC)	Y	N	Whilst this was included in the 2012 study, we consider that VSC technology has matured such that future CSC installations are unlikely in GB.
HVDC – Voltage Sourced Converter (VSC)	Y	Y	<p>Restricted to symmetrical monopole topology for up to 500 MW and symmetrical monopole/bi-pole topology above this power rating.</p> <p>Sensitivity analysis to be provided to indicate differences between onshore and offshore converter station locations.</p>
HVAC	Y	Y	Assumed that for route lengths greater than 100 km a mid-point reactive compensation platform is likely to be required.

Table A.4: Alternative Technologies Scope

Description	Included in 2012 Study?	Included in Current Study?	Mott MacDonald Comments
400 kV Gas-insulated Line (GIL)	Y	Y	In the 2012 study, this was directly compared with the overhead line and underground cable technologies. We consider GIL is most likely to be suitable for relatively short distances. The TOs have stated that they have no plans for installation of this technology outside a substation environment, and therefore a cost assessment is not included.
Superconducting Cables	N	Y	We consider that superconducting technologies are likely to be restricted to short route lengths in the short to medium term. We are not aware of such technologies being in use within GB and as such actual use data within the region is not available. We will provide indicative pricing based on supplier information which could be compared against the established technologies for short route lengths.
Multi-terminal HVDC links	N	Y	Whilst point-to-point HVDC links have become established technology, multi-terminal links are still maturing. However, the HND along with other recent policy reviews indicate that multi-terminal HVDC links are likely to be employed, and there is one example of a recent installation on the GB system. We will provide a typical example of a three-terminal HVDC offshore link. Sensitivity analysis will be provided to address locating converter stations onshore vs offshore.
Reconductoring of existing overhead lines	N	Y	We will consider a typical scenario of reconductoring of an existing overhead line with "high-temperature, low-sag" (HTLS) conductor to increase the rating of the circuit.
Alternative Tower Technologies	N	Y	We will consider the use of T-Pylons, consider their potential applications, and provide potential sensitivity adjustments which could be applied to the evaluation of the conventional overhead line designs.
Increasing Use of Existing Thermal Capacity	N	Y	We will provide typical applications, benefits/limitations, and an evaluation, on the use of the following technologies: <ul style="list-style-type: none"> ● Quadrature Booster. ● Thyristor Controlled Series Capacitor (TCSC). ● Static Series Synchronous Compensator (SSSC).
Onshore HVDC	N	Y	Whilst the HND does not currently indicate the use of any onshore HVDC links, these have been deployed in other countries. We propose to provide a typical application and indicative cost for each of the following cases: <ul style="list-style-type: none"> ● 2 GW VSC converter, +/- 525 kV XLPE cable, 700 km length. We consider 2 GW to be the likely limit using current technology for both XLPE cables and VSC converters. ● 8 GW LCC converter, +/- 800 kV overhead line, 700 km length. Whilst VSC technology is limited to approximately 2,000 A, there is established LCC technology which can accommodate 5,000 A and which has been deployed at +/- 800 kV. We propose a conventional bi-pole configuration such that in the event of a fault on one conductor the maximum loss of capacity would be 4 GW which would be comparable to some overhead line configurations.
765 kV a.c. Overhead Line	N	Y	Whilst the HND does not currently indicate the use of such high voltages, these have been deployed in other countries. We expect this would only be considered for very long distances and propose studying a 700 km single overhead line route.

Table A.5: Exclusions

Description	Mott MacDonald Comments
Alternative a.c. Voltage levels (lower than 400 kV a.c.)	Whilst some TOs own assets at 132 kV, 220 kV and 275 kV, in our experience and based on the HND, we expect that the majority of enhancement of boundary transfer capability will likely be at 400 kV. We will include some sensitivity analysis in respect of cost differences for the lower transmission voltage levels.
Reactive Power Compensation	The focus of this report is primarily around the installation of new circuits, or upgrade of existing circuits to facilitate increased capacity. Whilst in some circumstances reactive power compensation may increase the capacity of existing circuits, we consider this is not the prime purpose and as such we have not considered shunt reactors, capacitor banks, Static Var compensators (SVC) or Static Compensators (STACOM).
Conversion of existing a.c. OHL for use with HVDC	At this stage we consider it unlikely that existing overhead line routes would be reconfigured for this purpose due to the knock-on impacts on the a.c. system topology. Further we do not envisage that this would significantly enhance transmission capacity which is the main subject of this report.

A.4 Methodology

In general, the methodology will follow these steps:

1. Agree terms of reference with Project Board.
2. Establish benchmark ratings and reference scenarios for pricing purposes.
3. Obtain input data from suppliers, contractors, TOs, ESO and publicly available data sources.
4. Undertake engagement with TO representatives to obtain data which only they will be able to provide. This may include items such as project management costs, legal fees, stakeholder engagement fees, environmental costs and other similar aspects.
5. Data analysis and workshops with key participants.
6. Undertake cost assessment based on data obtained.
7. Undertake analysis of non-cost characteristics to factor in areas other than cost.
8. Production of report.
9. Stakeholder engagements.

As already explained, the execution of this assignment will be overseen by the Project Board. Mott MacDonald and the Project Board will keep the ToR and programme under review for the duration of the assignment and adjust if necessary.

A.4.1 Ratings and Circuit Lengths

In order to be able to carry out an accurate comparison between the different technologies, it is necessary to establish some circuit parameters and design assumptions. The 2012 report used three different cases, namely a high, medium and low rating situation and we consider this is still a valid approach. We have used the contents of National Grid Technical Guidance Note 26 (TGN1026, currently at issue 6 and dated February 2021 at the time of producing this report) as a basis for establishing ratings for overhead lines.

Consideration has also been given to switchgear ratings. Historically standard ratings at 400 kV have been 4,000 A at 40 degrees Celsius ambient temperature, which equates to approximately 2,771 MVA. However, 5,000 A (40 deg C ambient) switchgear is also available, equating to around 3,464 MVA. We have based our circuit ratings on winter post-fault scenarios. As such we consider using a 10 degrees Celsius ambient temperature for switchgear rating to be more appropriate. Using the methodology defined in IEC62271-306, the following maximum loadings could be considered:

Table A.6: Standard switchgear post-fault capability

40 degrees C Ambient Temperature		10 degrees C Ambient Temperature	
Current Rating (A)	MVA	Post-Fault Loading (A)	MVA
4,000	2,771	4,823	3,341
5,000	3,464	6,050	4,192

Finally, consideration has also been given to practical installation parameters. We consider it likely that circuits will compose of both cable and overhead line portions, and in these circumstances the cable section will be the limiting factor. At the present time a 400 kV a.c. cable using a 2,500 mm² conductor could be considered relatively standard. Whilst we understand that 3,000 mm² copper conductors are available, we are not aware of them having a proven installation track record, and we consider the increase in rating which could be obtained would not be significant. Therefore, our low, medium and high scenarios are based on using one, two and three 2,500 mm² copper conductors per phase respectively, and the rating which we have assumed per conductor is based on recent project experience.

Table A.7: Onshore OHL and UGC Ratings Table

Rating Case	Description	Rating per circuit (winter post-fault for OHL, 24 hour emergency for cable)	Circuit Configuration	Conductor Type
Onshore -Low	Based on standard construction twin 570 mm ² AAAC @90 deg C but limited by cable	2,420 MVA/3,493 A for OHL, but limited to 1,247 MVA/1,800 A by cable circuit	● OHL: Double Circuit on L8 towers	● OHL: 2x570 mm ² AAAC per phase
			● UGC: two circuits in separate trenches	● UGC: 1x2,500 mm ² copper conductor per phase
			● Tunnel: two circuits in 3 m diameter tunnel with 3.5 m/s air speed	● 1x2,500 mm ² copper conductor per phase
Onshore -Medium	Based on standard construction twin 850 mm ² AAAC @90 deg C but limited by cable	3,190 MVA/4,600 A for OHL, but limited to 2,494 MVA/3,600 A by cable circuit	● OHL: Double Circuit on L12 towers	● OHL: 2x850 mm ² AAAC conductor per phase
			● UGC: two circuits in four separate trenches	● UGC: 2x2,500 mm ² copper conductor per phase
			● Tunnel: two circuits in 4 m diameter tunnel with 3.5 m/s air speed	● 2x2,500 mm ² copper conductor per phase
Onshore -High	Based on standard construction triple 700 mm ² AAAC @90 deg C, but limited by switchgear and cable	4,210 MVA/6,077 A for OHL but limited by switchgear to 4,192 MVA/6,050 A. However, overall limited by cable to 3,741 MVA/5,400 A	● OHL: Double Circuit on L13 towers	● OHL: 3x700 mm ² AAAC per phase
			● UGC: two circuits in four separate trenches	● UGC: 3x2,500 mm ² copper conductor per phase
			● Tunnel: two circuits in 4 m diameter tunnel with 10 m/s air speed	● 2x2,500 mm ² copper conductor per phase

The underground cable and overhead line configurations will be considered for route lengths of 3 km, 15 km and 75 km, as may be typically expected to be seen onshore, and as considered in the 2012 report. The tunnel configuration will be considered for 3 km and 15 km route lengths only as it is not considered likely that a tunnel significantly in excess of this distance would be constructed.

In respect of offshore, HVDC technology has matured significantly since the 2012 report, in particular with respect to VSC systems. Having reviewed the HND, it is clear that both a.c. and HVDC offshore systems are still being considered. Although a.c. is generally limited to radial (i.e. non-meshed) applications which operate independently and have no benefit for the onshore transmission system.

The rating cases are primarily determined by HVDC converter and cable technology and are based on equipment which the supply chain has contracted to deliver by 2025.

Where these HVDC links are used to connect offshore generation, the Security and Quality of Supply Standard (SQSS) must also be considered and may constrain transmission capacity. At present the maximum infeed loss to the NETS is limited to 1,320 MW for a converter fault or 1,800 MW for a cable fault. However, the offshore transmission network review has recommended a change to the SQSS which would harmonise this limit at 1,800 MW for any fault.

Table A.8: Offshore ratings table

Rating Case	Description	Rating of Circuit	Circuit Configuration	Indicative Conductor Type
Offshore -Low	Expected practical limit of single circuit subsea a.c. cable systems	500 MW	● HVDC: 500 MW symmetrical monopole.	● 320 kV bundled pair, XLPE 1,000 mm ² aluminium.
			● HVAC: 1x500 MW circuit.	● 275 kV three-phase cable. Conductor 1,200 mm ² copper.
Offshore -Medium	Limit of HVDC symmetrical monopole systems	1,000 MW	● HVDC: 1,000 MW symmetrical monopole.	● 320 kV bundled pair, XLPE 1,800 mm ² copper.
			● HVAC: 2x500 MW circuits.	● 275 kV three-phase cable. Conductor 1,200 mm ² copper.
Offshore -High	Limit of HVDC VSC bi-pole systems	2,000 MW	● HVDC: Single 2,000 MW bi-pole.	● 525 kV, bundled pair. XLPE 2,500 mm ² copper.
			● HVAC: 4x500 MW circuits.	● 275 kV three-phase cable. Conductor 1,200 mm ² copper.

The above configurations will be considered for route lengths of 90 km, 180 km and 275 km which is envisaged to encompass most distances which could reasonably be expected to be required for the GB NETS. Whilst it is noted that there are interconnectors which have, or will have, distances which are well in excess of these distances, we do not envisage that such long HVDC links will be required for the GB NETS.

We note that the HND states the following in Section 4.1: “For some HVDC circuits, larger than 1.8 GW, the cables need to be separated and an extra metallic return conductor (which can be co-axially added to the outer sheath of the power cables)”. At this stage we do not consider coaxial cable to be a proven approach, and availability of cost data is likely to be an issue. As such, our proposal is to consider standard 525 kV cables (with a separate metallic earth return, if required).

A.4.2 Cost Assessment Considerations

For each of the options considered, a cost assessment will be undertaken, allowing a comparison of different technologies against different distance and rating requirements. In order to allow comparison with the 2012 report it is proposed to present the costs in the same manner including the following elements:

Table A.9: Cost Assessment Considerations

Item	Description
Fixed Build Costs	This includes construction costs which are independent of the route length. For example, for a cable circuit it would include the cable terminations and testing, or for a HVDC link it would include the converter stations.
Variable Build Costs	This includes construction costs which depend on the length of the circuit, such as materials costs, installation costs, project management, and risk/contingency.
Variable Operating Costs	This will include the expected costs of operating and maintaining the asset over its lifetime. This will include the cost of energy losses (due to heating), and operation and maintenance costs including any major replacement or refurbishment requirements. We assume the life of the assets will be considered as 40 years, as is standard for most transmission assets. We note that the previous report also included the "Power Losses" which were defined as the cost of building the extra generation equipment to compensate for the energy losses. This is not considered as part of this latest report.
Cost Sensitivities	We will present certain sensitivities indicating how the lifetime cost may vary based on certain specific factors which are to be defined. The full range of sensitivities will be agreed with the Project Board, depending on the case selected, and may include items such as circuit loading, exchange rate, base metal costs and other similar factors.
Lifetime Cost Results	This will include the overall cost of the proposed option, the cost per km, and an expression of the costs in "£/MVA-km". In calculating these values we will use the circuit rating, as given in Table A. and Table A.

Costs will be presented in current terms, that is Q1 2023, and in pounds sterling.

A.4.3 Non-Cost Characteristics Considerations

Whilst the 2012 study was primarily cost-based, for this study an evaluation will also be undertaken based on several other non-cost characteristics. Whilst the exact methodology for evaluation will be discussed and agreed with the Project Board, we have presented the criteria below which we intend to use for assessment, some of which are aligned with those considered as part of the HND:

Table A.10: Criteria

Title	Description
Cost	Based on the outcome of the cost assessment as described above.
Environmental Impact	We will assess the likely impact on the environment which the chosen technology may have.
Local Impact	We will assess the likely local impact including on local communities, which the chosen technology may have.
Carbon Content	We will evaluate the embedded carbon content of the chosen technology, together with the lifetime carbon impacts.
Climate Resilience	We will undertake a review of the chosen technology's likely resilience to climate events such as extreme weather, increased temperatures or flooding.
Technology Readiness	So far as possible we will ascertain the technology readiness level of the proposed technology. We will consider the track record of the technology and its readiness to be deployed at scale.
Adaptability	<ul style="list-style-type: none"> We will consider the ability of the proposed technology to adapt to different installation conditions or obstacles. We will consider the ability of the proposed technology to be extensible or adaptable to future system needs.
Programme	We will consider the typical duration of an engineer/procure/construction (EPC) programme for the technology types.

We recognise that, whilst some of these items can be assessed in a quantitative manner, for some areas a qualitative evaluation will be required. The exact methodology of undertaking such an assessment is to be agreed with the Project Board prior to undertaking the assessments.

It is not envisaged that comparison of every study case will be undertaken as the results are likely to be similar, irrespective of the loading of the line. Instead, it is considered more beneficial to undertake such an analysis against the differing technologies to be deployed. Further, as such analysis is usually used to compare or rank different options, it may not be possible to apply this to some of the options studied, especially those classified as “alternative technologies”.

Further detail will be provided in the methodology write-up including a discussion around use of weighting factors on a project-by-project basis.

A.5 Output

The output will be the provision of an updated version of the 2012 report which will provide an independent and authoritative view, and comparative whole-life costs for the scope areas defined in these terms of reference. The objective is to provide a clear and simple analysis, written in plain English in a manner that is clearly understandable to the general public and non-technical readers.

It is intended to present the report in the same manner as the 2012 document, for reasons of familiarity to most users; that is by having a relatively succinct main document along with a suitable suite of technical appendices which provide further detail in specific areas.

B. Consultant Team Members

Mott MacDonald's team in relation to this project included the following:

Table B.1: Consultant's Team Members

Name	Role
Project Management Team:	
Fay Lelliott	Project Principal
Paul Fletcher	Technical Principal
David Reid	Project Manager/Lead Engineer
Duncan Broom	Quality Assurance
Dermot Scanlon	Stakeholder Engagement Lead
Reena Bhandari	Project Co-Ordinator
Overhead Lines:	
Javier Lopez Nieto	Lead Engineer – Overhead Lines
Aleksandar Obradovic	Engineer – Overhead Lines
Cables:	
Mark Geary	Lead Engineer – Cables
Ali Baker	Electrical Engineer
Dominic Leeburn	Electrical Engineer
Kenneth Benton	Electrical Engineer
Electrical Engineering:	
Ian Kiely	Electrical Engineer
Shane O'Keefe	Electrical Engineer
Environmental:	
Ric Sandifer	Lead Consultant – Environmental
Sam Connolley	Consultant – Environmental
Aneira Jones	Consultant – Environmental
Carbon:	
Mark Crouch	Lead Consultant – Carbon
David Ovenstone	Carbon Consultant
Lydia Wong	Carbon Consultant
Non-Cost Characteristics	
Guy Knapp	Analyst
Omotola Adeoye	Analyst

C. Costing Methodology

C.1 Introduction

The following section describes the methodology used for undertaking the cost and ratings assessment of the different technologies chosen for study. In general, we have sought to follow a similar approach to that of the 2012 study, and to present the results in a similar manner, for consistency between reports. The results are presented in Section 4 of this report, with details surrounding the methodology and further analysis presented in this Appendix.

The general methodology for obtaining cost information on each technology was to:

10. Establish technologies and ratings which are to be used for pricing purposes.
11. Obtain input data from suppliers, contractors, TOs, ESO and publicly available data sources.
12. Undertake data analysis of costs received.
13. Undertake cost assessment and sensitivity analysis based on data.

Tables 3.2, 3.3 and 3.4 in this report define the different technologies and ratings which have been chosen for study. Section 3.4 then provides further details in respect of our approach to the market. As highlighted in those sections of the report, obtaining input from the market has proved challenging and as a result three different cost assessment methodologies have been used which are summarised as follows:

- **Using supply chain and TO data:** Where data has been provided by the TOs and the supply chain this has been used to undertake a cost and ratings assessment.
- **Using public domain information or a limited set of TO data:** In some instances we were unable to obtain any data from either the TOs or the supply chain, or only obtained a limited data-set. In this instance we have undertaken a cost and ratings assessment using information available in the public domain from other similar projects, a limited data-set, or a combination. In instances where this approach has been used the level of granularity provided is generally less.
- **Derivation from one of the above:** For some technologies information was not available from either source, for example if the technology is new, or if there is only a limited amount of projects which have previously been delivered and for which no data has been published. In such instances, in order to provide context for the report, we have estimated costs based on derivation from one of the above methods. In such instances the level of cost accuracy is comparatively lower. However, it was considered important to provide an indication as to where the price-point may sit, to allow for production of a complete report.

In the main body of the report the colour coding above is used to highlight the data source for the calculations. As highlighted throughout this report, the costs presented do not reflect the actual cost which will be incurred for a given scenario. The only way to achieve cost certainty for a particular project is to fully define it and award a contract for construction and even then it is likely that costs will vary during project execution. The cost estimates presented in this report are intended to allow a relative comparison between the different technologies, by providing an estimate based on common parameters. The actual cost will vary on a project by project basis. The costs presented here should not be relied upon for project estimating purposes or for making investment decisions.

C.2 Common Steps

C.2.1 Lifetime Cost Assessment

Irrespective of the methodology used there are some common steps which have been followed. Once data is obtained from private and public sources it needs to be checked for validity. The items which have been costed need to be confirmed against what was asked for and a levelling exercise may be required to either add or remove items of scope to ensure a like for like comparison across all data sources. This is resolved via discussion with the data provider.

Data provided has also been adjusted for inflation, and converted to GBP currency. As such we consider the information provided to be representative of 2023 prices in GB.

Once a usable set of data on the cost components of each technology is obtained, the cost assessment is carried out and breaks down final cost into three main categories:

14. Fixed Build Cost: Construction costs that are invariant to an increase in transmission length.

15. Variable Build Cost: Construction costs that increase in proportion to transmission length.

16. Variable Operating Cost: Operation costs that occur over the lifetime of the equipment.

Where possible, for every combination of length and power, the three cost categories are broken down into specific items (e.g. materials, installation costs etc for variable build). So far as possible, these are the same as the previous report for comparison purposes. A total build cost and operating cost are then presented.

These are then used to produce a total lifetime cost for the case in question. This is divided by route length to get the lifetime cost per distance (£/km), and the power to obtain a “power transfer cost” (£/MWkm) enabling a like for like comparison of each technology.

C.2.2 Sensitivity analysis

Once the lifetime costs are obtained, a sensitivity analysis can be performed. This considers the effect of different assumptions or external events to the output figure and determines which assumption/variable has the most effect on the lifetime cost estimate.

The sensitivity parameters explored are generally similar to those of the previous report to provide a point of comparison, with some additional sensitivities considered in certain instances. A minimum and maximum value for each parameter is used to determine the percentage change of the lifetime cost and the difference is compared against the baseline. The minimum and maximum value used is based on our professional judgement as to what should be considered reasonable for each specific parameter on the basis of current industry trends or past project experience. Where there is no basis then a range of +/- 50% may be used. It should be noted that sensitivity ranges are not always symmetrical. We have aimed for a consistent approach so far as possible across all technologies to facilitate straightforward comparison. The table below details the sensitivities which have been used:

Table C.1: Description of Sensitivities

Applicable Technology	Title	Description
Common to all	Route Length	The cases presented are for specific route lengths. This sensitivity is intended to provide an indication as to the impact that varying the route length may have.
	Circuit Loading	Base case assumptions for circuit loading are described in Appendix I. This sensitivity provides an indication as to the impact which variations in circuit loading may have.

Applicable Technology	Title	Description
	Base-metal Price	This sensitivity indicates the impact which variations in base-metal prices of materials such as aluminium, copper and steel may have.
	Exchange Rate	This sensitivity indicates the impact which exchange rate variations may have.
	Market Conditions	This sensitivity considers the impact that market conditions may have on prices, for example during times of high demand, prices may also be higher.
	Installation Cost	This considers the impact which variations in installation costs may have, for example as a result of higher labour costs.
	Materials Cost	This considers the impact which variations in the cost of materials may have.
OHL, UGC, Tunnels	Ground Conditions	Considers the impact different ground conditions may have in areas such as construction access, design and time/cost of installation.
	Route Directness	This considers the impact of any deviation to the intended route which may be required to negotiate obstructions, and which may lead to additional costs or design measures.
	Terrain	Consideration as to flat/undulating/hilly terrain or rural/urban/mixed environment and the associated impact on construction costs.
OHL, UGC	Significant Crossings (OHL)/Special Constructions (UGC)	For OHL this would consider costs associated with crossing infrastructure such as motorways and railways, for UGC this considers the requirement for special constructions such as HDD for crossing infrastructure or obstructions.
HVAC submarine cable and HVDC	Bad Weather	Impact of bad weather on construction programme.
	Special Constructions	Impact of areas such as complex marine landings and quantity of crossings of other assets.
	Maintenance/Refurbishment Cost	Considers differences in requirements for maintenance and refurbishment including any mid-life replacements.
	Seabed Conditions and cable burial	Impact of different seabed conditions and complexity or depth of cable burial.
HVDC	Converter Station Location	Difference between having two converter stations onshore, one onshore and one offshore, or both offshore.

C.2.3 Variable Operating Costs

The variable operating costs are made up of both losses and operation and maintenance (O&M) costs. In respect of losses, these are described further in Appendix I which also provides a cost calculation for each case which has been considered. As mentioned in Appendix I, the 2012 study considered two costs associated with losses as follows:

- **Energy Losses:** The direct cost of the electrical energy which is “lost” during electricity transmission which is termed the energy loss. In order to assess the cost, the losses can be quantified in terms of kWh, and multiplied by a typical unit cost of electricity.
- **Power Losses:** The cost of installing additional generation capacity in order to compensate for these losses which is termed the power loss.

As discussed in Appendix A (terms of reference) and Appendix I (losses), it is our view that valuing losses on the basis of the wholesale power cost (which necessarily has to recover the capital investment in the generating plant, the fixed maintenance costs and the marginal costs of operating that plant, such as fuel costs) provides a meaningful metric to facilitate comparison between different types of technologies. We have thus only considered energy losses in this updated report.

In respect of operation and maintenance costs we have used the following methodology:

Table C.2: O&M Assumptions

Technology	Methodology	Outcome
HVAC Onshore-Offshore	We have not located a significant volume of information in respect of HVAC offshore transmission operation and maintenance costs. However, a national audit office document is available from 2012 which examines the costs associated with the initial offshore transmission licenses ²⁸ . This analysed 12 bids and identified that the annual operation and maintenance costs associated with these ranged between 0.9% and 4.4% of transfer value annually, with the winning bid at the "lower end" of this range as a result of the competition generated. The average percentage of the above bids would be approximately 2.24%. However, given that winning bids were lower, and given that improvements are likely to have been made since 2012 due to the industry maturing, we have assumed a value of 1.5% for the purposes of this study.	Assumed value of 1.5% of CAPEX per annum.
HVDC Onshore-Onshore	We have examined the data for submarine interconnectors under Ofgem's cap and floor regime which includes estimated OPEX costs. In the assessments published by Ofgem both OPEX and CAPEX costs are presented in "real" terms for the year of assessment with any discounted cash-flow adjustments being taken into consideration at a later stage of the process. We have divided the OPEX by the CAPEX to get a figure for "OPEX as a percentage of CAPEX", and divided this by the regime duration of 25 years to get a per annum figure. There is a limited data set available which provided results of 2%, 2.5%, 3%, 4.4% and 6%. As with the OFTO regime mentioned above, it is likely that figures towards the lower end of this range could be expected as a result of competition generated. As such we consider 2.5% to be a reasonable assumption.	Assumed value of 2.5% of CAPEX per annum.
HVDC Onshore-Offshore	We have been unable to locate any publicly available information in this regard. Costs would be expected to be higher than those for an onshore-onshore system, due to the presence of an offshore platform. We have therefore added an additional 0.5% per annum to the cost of the onshore-onshore solution.	Assumed value of 3.0% of CAPEX per annum.
Onshore assets (e.g. OHL, UGC etc) excluding long-distance	For onshore assets we have applied a standard percentage O&M charge based on NGET's charging statement ²⁹ . This currently indicates a site specific maintenance factor (SSM) of 0.39% of the asset value, which we have rounded up to 0.4%.	Assumed value of 0.4% of CAPEX per annum.
Long-distance onshore transmission	As no such assets are currently in-service in GB we have assumed some O&M percentage charges based on the technologies listed above. The HVDC onshore-onshore technology assumes a rate of 2.5% which would include O&M activities associated with the offshore cable system including surveys, subsea repairs and, if required, re-burial. As such activities would not be expected for onshore cable systems, we have assumed a 1.5% O&M value for the onshore HVDC systems (8 GW LCC and 2 GW VSC). Similarly for the 765kV long distance overhead line, we consider that additional costs may be incurred as compared to the currently used transmission assets. These may be as a result of needing to up-skill or re-train	Assumed value of 1.5% of CAPEX per annum.

²⁸ <https://www.nao.org.uk/wp-content/uploads/2012/06/121322.pdf>

²⁹ <https://www.nationalgrid.com/electricity-transmission/document/148171/download>

Technology	Methodology	Outcome
	staff, costs associated with specialist equipment to service the assets, a lack of economies of scale, and the distance over which the asset may be spread. We consider that the 1.5% O&M value applied to the long-distance HVDC projects may also be representative, and that it also allows for straightforward comparison between all long-distance technologies.	

Variable operating costs consider the entire costs accumulated over the lifespan of the asset. For onshore assets, lifespan is assumed to be 40 years, while for offshore assets this is 25 years due to the harsher environmental conditions. Due to inflation and depreciation of assets, we cannot assume the asset will maintain the same operating costs year-on-year as it did when first commissioned. We can account for this however using a discount rate figure, which estimates the annual percentage reduction of these costs relative to today's value. By summing this discounted figure for each year, the net present value, i.e., the total OPEX can be found. We have used a discount rate of 4.00% based on NGET's charging statement for Weighted Average Cost of Capital²⁹.

C.2.4 Reactive Compensation Costs

As explained in Appendix E of this report, the installation of underground cables contributes to the reactive power requirements of the NETS and necessitates the installation of compensation equipment for circuits above a certain length. The 2012 study assumes that, whilst shorter cable lengths may not directly lead to the requirement to install a reactor, all cable lengths contribute to the system reactive power requirements, and thus the study applied a cost for reactive power compensation per km of cable. It also assumed that onshore, a 2,500 mm² double circuit cable route using a single conductor per phase would require 11.3 MVar of compensation per km. We have followed the same assumption in the current report. We have obtained current market data and determined that the cost of a 200 MVar shunt reactor is in the region of £8.6m. As such, we have applied a cost of £43k per MVar, which equates to £485.9k per kilometre of onshore double circuit cable route with a single conductor per phase. For the medium case where two conductors per phase are required, and the high case where three conductors per phase are required, we have adjusted the amount accordingly. A different approach is taken for offshore assets as described in C.3.5.

We would like to highlight that in reality, reactive compensation is not applied on a "per-unit length" basis. Instead the need will be determined on a project specific basis, and the costs will be incurred as "lump sums" against some specific projects. However, as the aggregate effect of all assets on the system contributes to the overall requirements for reactive power, this approach has been used to reflect the impact which each technology may have.

C.2.5 Summary of Fixed and Variable Cost Components

Table C.3 summarises the different cost components which are presented for cases where estimation has been carried out using supply chain data as described in Section C.4. Table C.4 summarises the different cost components which are presented for the HVDC technologies and a.c. submarine cable technologies where estimation has generally been carried out using publicly available information as described in Section C.3.

Table C.3: Description of Cost Components – Main Onshore Technologies

Applicable Technology	Title	Description
<i>Fixed Costs</i>		

Applicable Technology	Title	Description
Common to all	Project Launch and Mobilisation	This includes the upfront costs which will be necessary to launch the project including areas such as: needs case identification, early stage designs, scheme sanction, establishment of project team, initial procurement/tendering activities.
UGC (buried and tunnelled), PAC and Superconducting Cable	Cable Sealing End Compound	The cost of constructing a cable sealing end compound at each end.
	Terminations and Testing	The cost of terminating and testing the conductor system.
Tunnels	Shafts and Headhouses	This covers the shafts and headhouses which will be required at each end of the tunnel. Note that for longer tunnels intermediate shafts will also be required which are included as variable cost components.
	Tunnel Boring Machine	This covers the upfront cost of purchasing the tunnel boring machine. For longer distances it will be necessary to purchase multiple machines and therefore strictly speaking this cost is not independent of distance. However, we have categorised it as a fixed cost as it will need to be paid upfront, and there are step changes depending on the distance as opposed to a continuous variation.
	Tunnel PM and Overheads	Due to the complexity of tunnelling operations a dedicated team is often set up to manage the works with an associated fixed cost. There are also other fixed elements required including the establishment of construction compounds and tunnel support equipment at either end of the tunnel. We have categorised this as a fixed cost for the same reasons as the tunnel boring machine.
Variable Costs		
Common to all	Project Management and Engineering	Variable costs associated with engineering and project management activities.
	Materials	Cost of materials.
	Installation	Installation/Construction costs.
	Contingency	Contingency allowance.
UGC (buried and tunnelled), PAC and Superconducting Cable	Reactive Compensation	Allowance for cost of reactive compensation as detailed in Section C2.4.
UGC (buried), PAC and Superconducting Cable	Special Constructions	Allowance for non-standard construction along part of the route such as ducted installation or HDD.
Tunnels	Tunnel and Shaft	Variable cost associated with construction of the tunnel and any intermediate shafts.
	Tunnel PM and Overheads	Variable costs associated with the tunnel PM team and supporting the tunnelling operations.

Table C.4: Description of Cost Components – HVDC and Submarine Cable

Applicable Technology	Title	Description
Fixed Costs		
HVDC	Converter Stations	The cost of all converter stations and associated grid connection infrastructure required for the case being evaluated, as described in Section C.3.1.
A.c. submarine cable	A.c. Connection Assets	The cost of a.c. onshore and offshore substation infrastructure as described in Section C.3.4 but not including any mid-point reactive compensation.

Applicable Technology	Title	Description
Variable Costs		
HVDC	HVDC cable system or overhead line (8 GW onshore LCC solution only)	The cost of the HVDC cable system as described in C.3.3 for submarine applications, or for the HVDC overhead line for the 8 GW onshore solution, as described in Section C.5.
A.c. submarine cable	Reactive compensation	The cost of any reactive compensation stations which are required along the cable route, as described in Section C.3.5.
	Submarine cable system	The cost of the submarine cable system as described in Section C.3.3.

C.3 Cost Assessment Using Publicly Available Information

This methodology has been used to assess the cost of the offshore transmission options, as information was not available from the TOs or the supply chain. Our approach has been to source as much information from the public domain as possible in respect of the different technologies. Data sources include existing published documents (as recorded in the bibliography), information from regulatory assessments (for example from the Ofgem website), and notifications of contract award in respect of specific projects. In many instances information in these sources is redacted or not broken down sufficiently to split it out into fixed/variable elements and as such a single representative cost for each main item has been derived. In some cases the cost provided may be only approximate, for example a data source may state that a contract has been awarded “in excess of £200m” for a particular length/type of cable. This clearly impacts on the accuracy of the pricing given below. However, we consider that by combining many data sources together, some of which are accurate, and some of which are approximate, the conclusions reached are representative of the price range which could reasonably be expected, and are suitable for the purpose of this study which is to provide a relative comparison of different technologies, as opposed to building up an accurate price for a particular project.

C.3.1 HVDC Converter Stations

We have compiled data from offshore wind projects and interconnector projects using HVDC technology. Following adjustment to present day prices to account for consumer price index (CPI), and exchange rate adjustments, the data has been plotted on a graph as indicated below. Whilst there are many project specific aspects which will impact on the precise cost of a particular project, we have applied a trend-line in excel which we consider gives a reasonable representation of the cost which may be incurred for a given capacity:

Figure C.1: HVDC Converter Station Costs

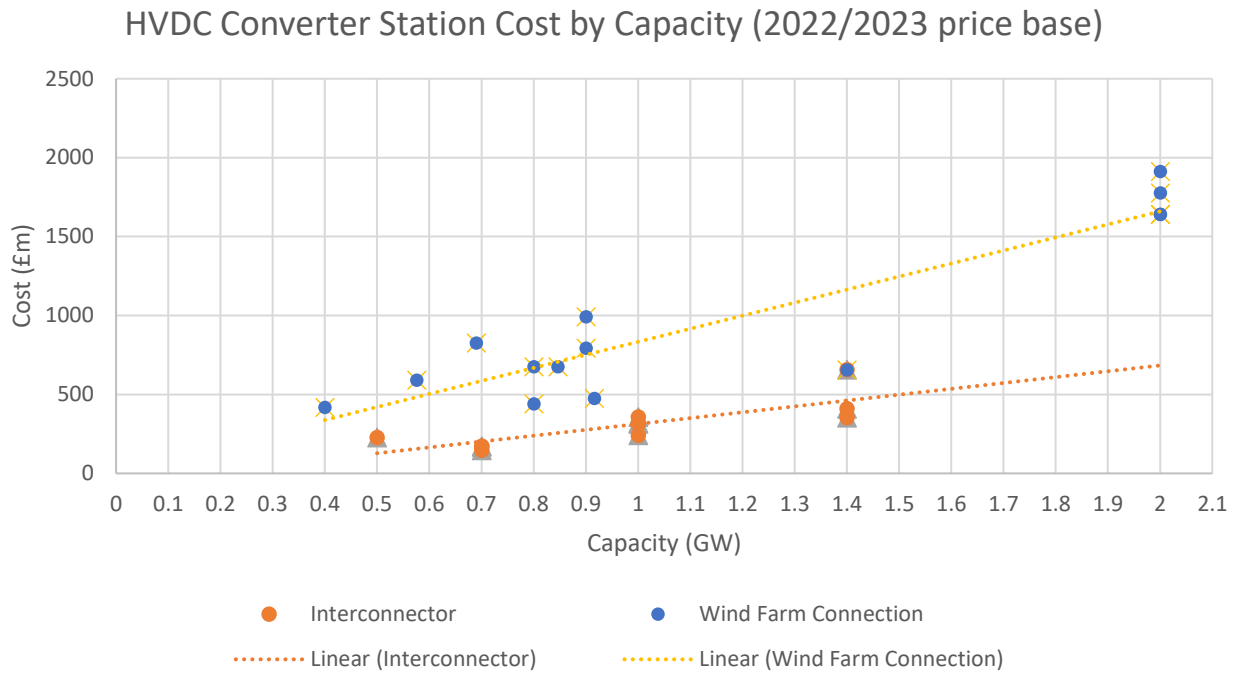

Source: Mott MacDonald based on public domain data

Using the graph above we can deduce the following costs for the scenarios considered in this study. These costs are representative of the converter stations and associated grid connections. It should be noted that for the 2 GW solution the data-set is very limited. Although contracts have been awarded, this type of asset has not yet been constructed and as such actual costs are not known.

Table C.5: HVDC Converter Station Costs

Rating (GW)	Cost – offshore/onshore	Cost – onshore/onshore	Difference	Ratio
0.5	£420m	£130m	£290m	3.2
1	£835m	£313m	£522m	2.7
2	£1,660m	£684m	£976m	2.4

C.3.2 HVDC Submarine Cable

We have compiled data from offshore wind projects and interconnector projects using HVDC technology which we have adjusted to present day prices to account for CPI, and exchange rate adjustments. Whilst there are many different factors which differentiate cable systems such as the operating voltage, insulation medium, conductor type and conductor size, it has not been possible to obtain this level of detail for many projects we have found. The most consistent data-set we have been able to obtain is in respect of cost, circuit length and design capacity. As a result we have converted the data to a £/km metric based on circuit length, and plotted this against capacity as indicated on the graph below.

Figure C.2: HVDC Cable Cost Per Unit Length vs GW Capacity

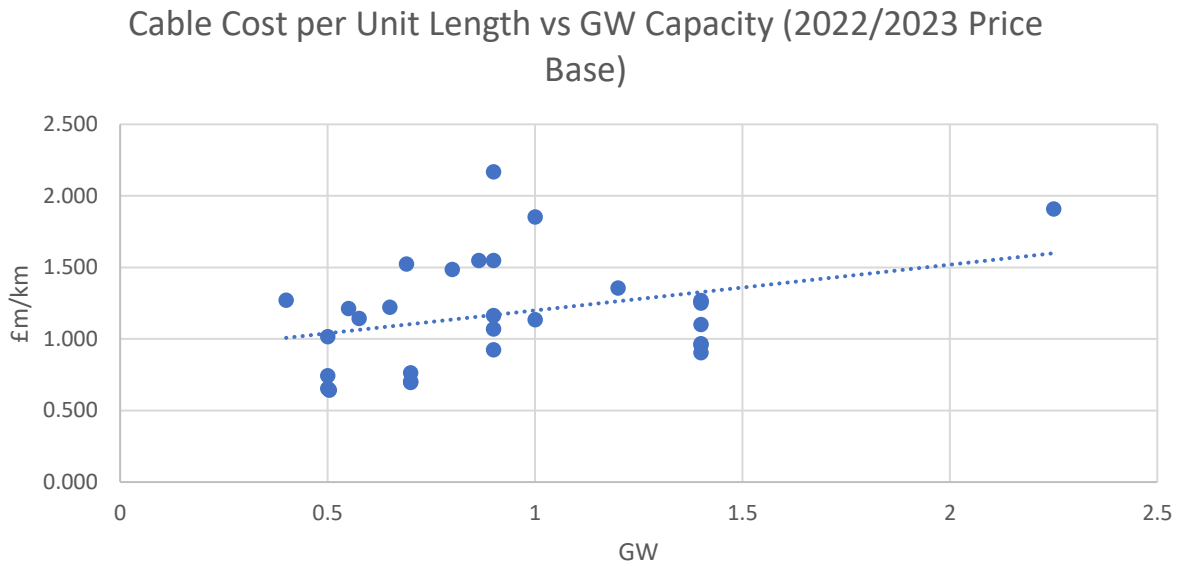

Source: Mott MacDonald based on public domain information

The projects we have examined usually include a short length of onshore cable but it has not been possible to obtain sufficient breakdown of costs to split this out in most cases. As such we consider the data provided above is representative of unit costs for projects where the majority of the route is offshore, but where a short land-based section is present at one or both ends. Using the graph above we can deduce the following costs for the scenarios considered in this study. These costs are representative of the HVDC cable system.

Table C.6: HVDC Submarine Cable Cost per Unit Length

Rating (GW)	Cost (£m/km)	Cost for 90 km (£m)	Cost for 180 km (£m)	Cost for 275 km (£m)
0.5	1.04	93.6	187.2	286.0
1.0	1.20	108.0	216.0	330.0
2.0	1.52	136.8	273.6	418.0

C.3.3 HVAC Submarine Cable

Whilst there are a number of OFTOs now in operation in GB, we were unable to identify data in the public domain which splits out the value of the submarine cable assets from the other items (such as offshore platform, grid connection etc). However, we have been able to obtain public domain information in respect of contract values which have been awarded. The same limitations apply as for HVDC submarine cables. The majority of information obtained is in respect of 220 kV a.c. cables which have been adjusted for exchange rates and CPI and an uplift applied to account for the fact that we are considering a 275 kV cable. We have found a small number of data points in respect of 275 kV cables. This results in the following graph.

Figure C.3: HVAC Cable Cost per km by Distance

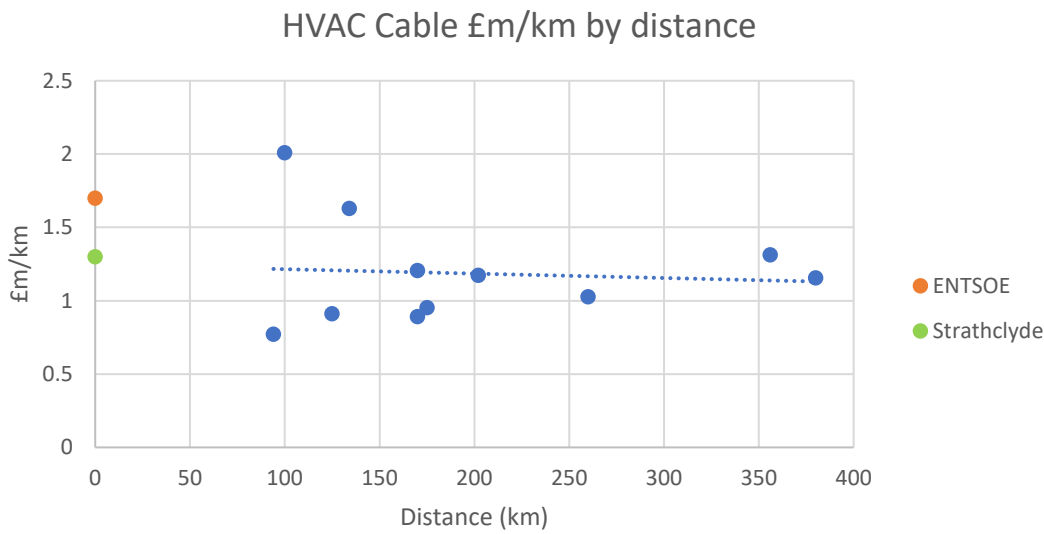

Source: Mott MacDonald based on public domain information

As can be seen, economies of scale are demonstrated for longer circuit lengths as would be expected, although these are relatively mild. We have compared this against two public domain data sources as follows:

- ENTSOE “Offshore Transmission Technology” document, 2011³⁰: When both supply and installation costs are considered, and the costs are uplifted to 2022/23 values, this gives a range of £1.2m-£2.2m per km, with the average being £1.7m per km, for a 245 kV 400 MVA cable.
- University of Strathclyde study titled “A comparison of AC and HVDC options for the connection of offshore wind generation in Great Britain”, 2015³¹: When both supply and installation costs are considered, and the costs are uplifted to 2022/23 values, this gives a figure of £1.3m per km for a 350 MW 220 kV cable.

Whilst the ENTSOE document produces a cost at the upper end of what could be expected, the adjusted University of Strathclyde value is of a similar order of magnitude to the trendline which has been plotted.

Our cases consider either a single 500 MW circuit, two 500 MW circuits, or four 500 MW circuits. The ENTSOE document indicates an assumption that two circuits installed in the same trench will result in around 1.9 times the cost of a single circuit. For four circuits we have not assumed any additional efficiencies as circuits are likely to be laid apart.

Applying the trend indicated in the graph above, and the efficiency factor for two circuits, provides us with the following overall costs:

³⁰ https://eepublicdownloads.entsoe.eu/clean-documents/pre2015/publications/entsoe/SDC/European_offshore_grid_-_Offshore_Technology_-_FINALversion.pdf

³¹ https://pure.strath.ac.uk/ws/portalfiles/portal/43387113/Elliott_etal_IEEE_TPD_2015_A_comparison_of_AC_and_HVDC_options_for_the_connection_of_offshore_wind_generation.pdf

Table C.7: Cost of a.c. Cables

Distance (km)	Cost for Single Circuit	Cost for Two Circuits	Cost for Four Circuits (£m)
90	£110m	£197m	£396m
180	£215m	£387m	£774m
275	£321m	£577m	£1,155m

C.3.4 HVAC Offshore Connection Assets

The connection of offshore transmission systems using a.c. assets requires infrastructure both onshore and offshore. A variety of components are required in both locations including reactive compensation, switchgear, harmonic filters and substation infrastructure (offshore platform or civil works for onshore substation). In order to establish indicative costs for such assets we have examined CAPEX costs as reported for GB OFTO assets by Ofgem. As these are not broken down in sufficient granularity to differentiate between cables and other infrastructure, we have used the projects for which we have been able to obtain a.c. cable cost data as discussed in Section C.3.3. This has been subtracted from the reported OFTO CAPEX costs and the results have been plotted against the capacity of the a.c. link in the graph below:

Figure C.4: Offshore a.c. Connection Assets by Capacity

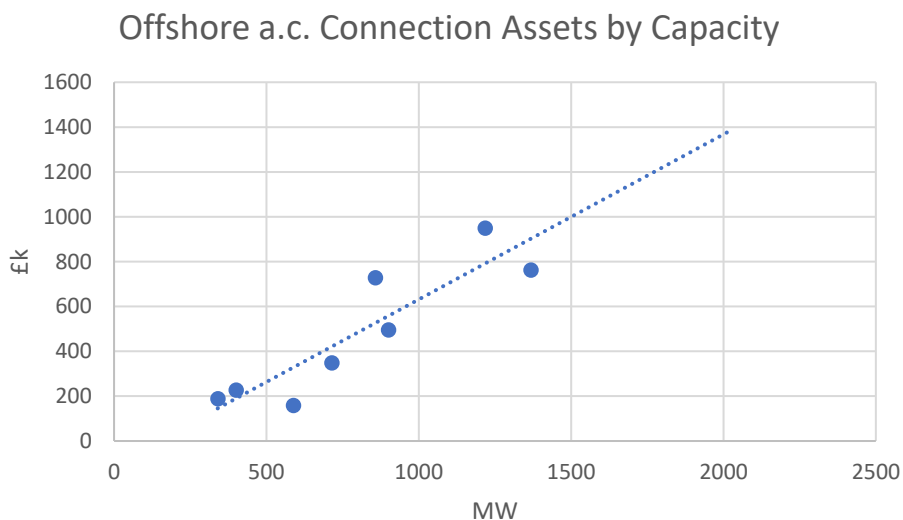

Source: Mott MacDonald based on public domain information

Using the graph above we can establish the following figures for the scenarios under consideration as part of this study:

Table C.8: Cost of a.c. Connection Assets

Capacity	Cost of a.c. Infrastructure Excluding Cable and Reactive Compensation Platform
0.5 GW	£263m
1.0 GW	£631m
2.0 GW	£1368m

C.3.5 Reactive Compensation

For long a.c. cable circuits it is necessary to install a reactive compensation station (RCS) part way along the cable route. There are only two projects we are aware of which have taken this approach, namely Hornsea 1 and Hornsea 2 in GB. We have been unable to obtain price information from the public domain in respect of the RCS associated with these projects. These generally consist of a small platform housing reactors, switchgear and ancillary systems. In order to estimate costs associated with such platforms we have used data obtained for onshore reactors, deducted costs associated with civil works, and added the cost of a platform which has been obtained from the 2011 ENTSOE report³². Based on high-level calculations we have determined that for a 90 km cable route, no RCS would be required. For a 180 km cable route it would be necessary to install an RCS and we have assumed that, per circuit, this would contain two reactors of approximately 200 MVar each. For the case where two circuits are required, a single larger platform can be used to house all four reactors. However, for the case where four circuits are required we have assumed that two separate platforms will be required. For a route length of 275 km it is likely that two RCSs will be required. Whilst an element of reactive compensation equipment has been allowed for within the a.c. connection assets, the level required for a 180 km or 275 km route would be in excess of what is currently factored in. Therefore additional costs have been added both offshore and onshore in respect of reactive compensation equipment. Overall, this results in the following costs for reactive compensation equipment:

Table C.9: Reactive Compensation Equipment Costs

Circuit Length	500 MW	1 GW	2 GW
180 km	£75m	£112m	£225m
275 km	£150m	£225m	£450m

C.3.6 CAPEX Costs for Offshore Solutions

Using the above building blocks we can estimate the following costs for the onshore-offshore scenarios considered in this study:

Table C.10: CAPEX for Offshore Solutions

Distance	500 MW		1 GW		2 GW	
	a.c.	HVDC	a.c.	HVDC	a.c.	HVDC
90 km	£373m	£513m	£829m	£943m	£1,763m	£1,796m
180 km	£553m	£607m	£1,131m	£1,051m	£2,367m	£1,933m
275 km	£734m	£706m	£1,433m	£1,165m	£2,972m	£2,078m

³² https://eepublicdownloads.entsoe.eu/clean-documents/pre2015/publications/entsoe/SDC/European_offshore_grid_-_Offshore_Technology_-_FINALversion.pdf

Figure C.5: Cost Against Distance for Offshore Solutions

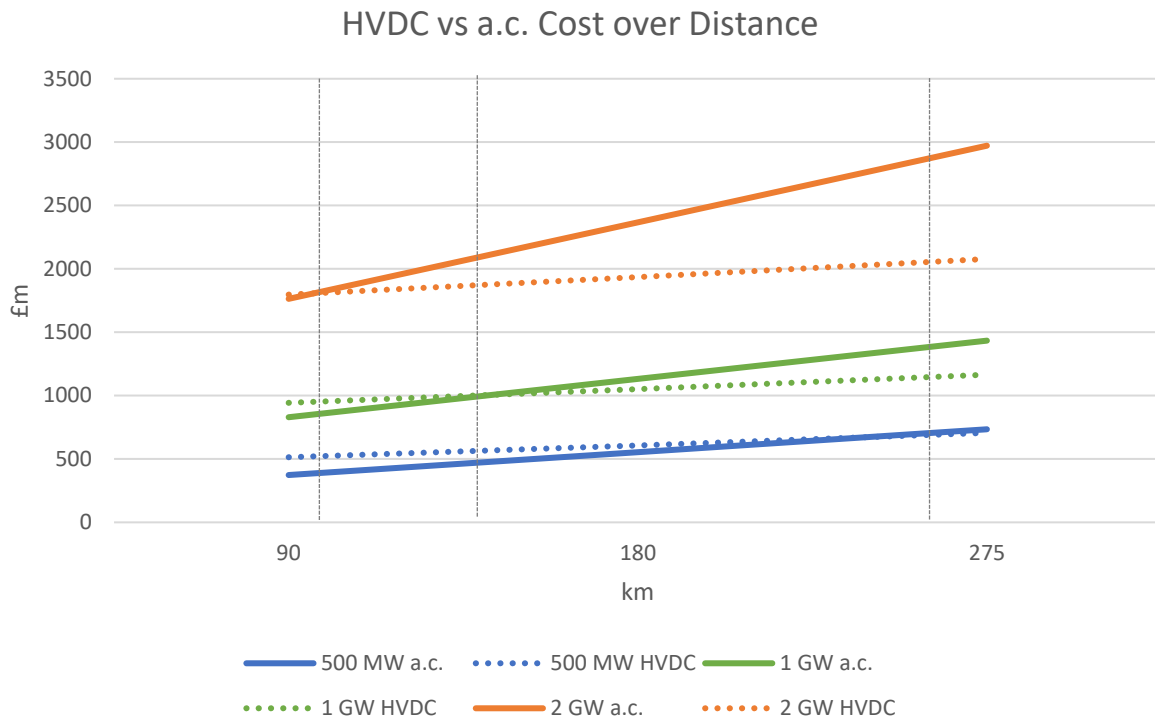

Source: Mott MacDonald based on public domain information

It is noted that the break-even distance for HVDC technologies is greater than may be seen in other documents on this subject. The reason is that our study considers the use of a single 275 kV a.c. cable to facilitate a 500 MW connection, whereas other studies may consider the use of two 220 kV a.c. cables to achieve the same result. The use of a single 275 kV a.c. cable for a 500 MW connection is indicated in the HND, and results in cost savings as compared to two 220 kV cables, and thus the break-even distance is greater.

C.4 Cost Assessment Using Supply Chain Data

This methodology has been used to assess the majority of onshore technologies such as underground cables and overhead lines. In these instances data has been provided by a number of sources including the TOs and the supply chain. We have undertaken a levelling exercise to ensure that the costing has been undertaken based on the same assumptions and scope. The levelised data has then been combined together to obtain an overall representative value for a particular cost item across a number of categories. In most instances the charts presented in Section 4 are self-explanatory as to what is included for each costing category, but an explanation is provided for certain instances as described below:

Table C.11: Description of Cost Items

Item Description	Mott MacDonald Comments
Mobilisation (OHL)	Fixed mobilisation cost including items such as establishment of site compounds and offices.
Project Launch and Management (UGC, tunnel)	This generally covers costs incurred by the TO including items such as stakeholder consultations, optioneering, initial surveys, administration tasks such as application for consents, and ongoing project management. For UGC, contractor project management costs are included separately as part of the installation cost, and for tunnels they are included under tunnel PM and overheads.
Project Management (OHL)	This covers the project management activities by the TO and Contractor.

Item Description	Mott MacDonald Comments
Special Constructions (UGC)	This covers temporary works, access roads, and includes a limited allowance for negotiation of obstacles along the route.
Contingency	In general an allowance of 10% of total build costs has been made across all technologies.
Tunnel and Shaft (tunnel)	Both a fixed and variable build cost are associated with this category. There are fixed upfront costs including design, surveys, and the shafts at start and finish points. There are then variable costs including the main tunnel construction, and additional shafts along the route.
Tunnel PM and Overheads (tunnel)	Construction of a tunnel is generally a complex organisation involving multiple parties. These costs are associated with the delivery organisation which could be a contractor, or a consortium. They generally cover both upfront costs (fixed) associated with establishing the delivery organisation and site compounds, and ongoing costs (variable) associated with delivering the project.

C.5 Cost Assessment by Derivation

In the case of superconductors, pressurised air cable, 765 kV overhead lines and an 8 GW LCC solution, no representative data has been found. Therefore, the following approach has been taken for each case:

Table C.12: Technology with Derived Costs

Technology	Cost Assessment Approach
Superconductors	We have obtained public domain information in respect of the cost of materials. We have then used this to derive an overall cost of a superconductor system based on the costs we have established for the "low" rating UGC.
Pressurised air cable	We have obtained supplier data in respect of the cost of materials. We have then used this to derive an overall cost of a pressurised air cable system based on the costs we have established for the "low" rating UGC in areas such as civil works and installation.
8 GW HVDC LCC	We have used the costs established for onshore HVDC equipment to derive the cost of the converter stations and connection assets associated with an 8 GW LCC solution. We have not included for the cost of diverting existing circuits into the converter stations. We have estimated the cost per km for a HVDC overhead line based on the 400 kV a.c. overhead line costs.
765 kV a.c. OHL	We have used supplier and TO data, along with in-house data, to estimate the costs associated with the a.c. infrastructure at each end of the OHL. We have estimated the cost of a single circuit 765 kV. We have estimated the cost per km for a HVDC overhead line based on the 400 kV a.c. overhead line costs, and our experience of similar projects in other countries. We have not included for the cost of diverting existing circuits into the 400/765 kV substation at either end.

D. Overhead Lines

Transmission networks around the world are built largely using overhead lines (OHL) through which the current flows between substations or from generation centres to consumption nodes. This section presents a high-level overview of the main components and equipment in overhead lines.

The purpose of this section of the report is to introduce some design, construction and operational aspects associated with overhead lines, providing some context for comparison against other available technologies. The following topics are covered:

- A description of the technology.
- The components behind the technology.
- Maintenance and decommissioning.
- Works associated with installation.
- Its application and uses.
- Alternative overhead line approaches and anticipated future developments.

D.1 Description of the Technology

In GB overhead lines have been used for transmission purposes since the 1930s and hence have a long track record, with designers, manufacturers, installation contractors, owners and operators being very familiar with their characteristics. They provide a cost-effective means of bulk power transmission, having a comparatively lower construction cost, and higher power rating, as compared to an equivalent underground cable. Although they are exposed to the environment, they are generally robust and resilient, and faults are relatively straightforward to locate and repair, thus resulting in high levels of availability. They can also be installed over greater distances as compared to underground cables, and the need for reactive compensation measures is reduced. The principal drawback is that they are seen as being visually intrusive, and thus there can sometimes be resistance in respect of planning approvals. In some instances they are also viewed as “old technology”, however this is not the case as there continue to be advances in technology in respect of support structures, conductors and insulators, and in any case despite the longevity of the technology, a more cost effective means of bulk power transfer over long distances has not yet been developed.

OHL are constructed by the installation of structures (poles, towers, pylons) that are designed, erected and installed to support the mechanical loads exerted on the conductors and the rest of the equipment. In transmission systems, they operate at high voltage levels (in GB typically 132 kV, 275 kV or 400 kV). They are held above ground and obstacles ensuring statutory safety distances are maintained according to the voltage level of the line and weather conditions (high wind speed, ice load, etc).

Figure D.1: Typical overhead line

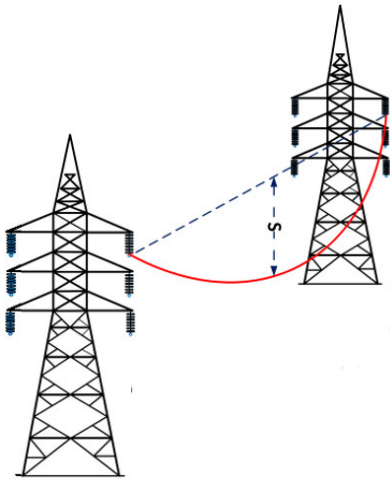

Source: "Measurement of Power Line Sagging Using Sensor Data of a Power Line Inspection Robot", IEEE, Jun. 8 2020. Licensed under [CC BY 4.0](https://creativecommons.org/licenses/by/4.0/). Available: <https://ieeexplore.ieee.org/stamp/stamp.jsp?arnumber=9103065>

D.2 Overhead Line Components

D.2.1 Conductors

Conductors carry the flow of electrical current. As the current flows through a conductor, heat is generated. The heat generated within a given environment is a function of the magnitude of the current flowing and the resistance of the conductor, and the heat generated results in an increase in temperature of the conductor. Conductors on overhead lines rarely have an insulating coating, instead relying on the air and thus requiring adequate physical separation between each conductor, and also from adjacent objects, structures or the ground. They are supported by towers located along the route, and at these locations insulator sets are provided which support the conductor and provide the necessary insulation between the conductor and the tower. As the temperature increases, the conductor will expand, resulting in "sag" and thus reducing clearances. Overhead lines are designed for a maximum operating temperature at which the necessary clearances can be maintained, and therefore a current rating is specified for overhead lines, at which the maximum operating temperature will not be exceeded.

Conductors have historically been manufactured using a combination of aluminium, aluminium alloy and/or steel wires. The most traditional conductor types are ACSR (Aluminium Conductor Steel Reinforced) and AAAC (All Aluminium Alloy Conductor) which have maximum operating temperatures of 75 °C – 90 °C. In the last 15 - 20 years new conductor materials and types have entered the market. These are known as High Temperature Low Sag conductors (HTLS) which allow for higher currents to be carried and higher operating temperatures (150 °C – 210 °C) but with null or minimal increase in the sag. The use of these conductors has proved to be very successful to increase the capacity of existing overhead lines by reconductoring existing circuits with HTLS. This technology is explained in more detail in Section D.6.2.

GB operates a three-phase transmission system and each phase of an overhead line circuit will usually consist of a "bundle" of several conductors together (typically between two and four) to increase the rating and enhance electrical performance.

D.2.2 Structures

As to the structures, different types and materials are used in their fabrication. For transmission lines, the most common types are steel lattice towers and steel poles, although the latter are not

commonly used in GB. However, other materials, such as wood or concrete are also used for the fabrication of poles. For any structure type considered (tower, pole, etc.) there are generally three different variants, examples shown in Figure E.2:

- Suspension structures: used in most locations with no deviation angle.
- Angle structures (also called Tension structures): used mostly where lines change direction and in some cases to provide anti-cascade failure.
- Terminal structures: located at OHL ending points; they are capable of withstanding loads on one side of the structure only.

Towers, also commonly called pylons, consist of a framework of individual steel members (usually hot-rolled angle section) that are bolted or welded together. Figure D.2 presents the three tower types mentioned above for a typical double circuit. As can be seen, each side of a tower carries the three separate phases, with an earth wire also installed separately on top of the tower.

Figure D.2: Typical tower variants: a) suspension tower, b) tension tower, c) terminal tower

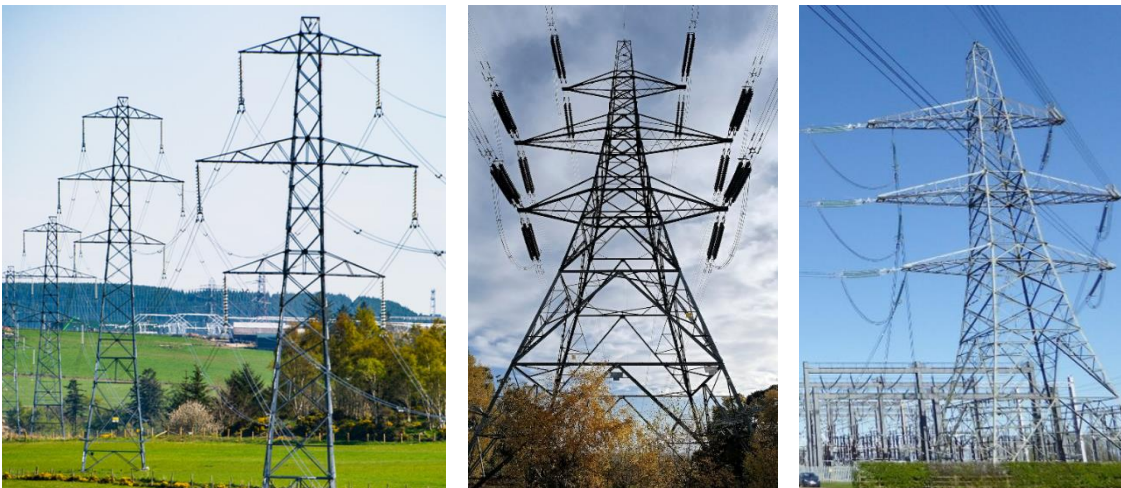

Source: a) "Project Map - Dunoon - Project Documents", SSEN, Jan. 2023. Available: <https://www.ssen-transmission.co.uk/projects/project-map/dunoon/>

Source: b) "A high tension pylon line viewed along the cables", Taken by Chris Barker on Unsplash, 2021. Licensed under [UnSplash License](https://unsplash.com/photos/aDm5_X_A2Z3k). Available at: https://unsplash.com/photos/aDm5_X_A2Z3k

Source: c) "National Grid Creyke Beck substation", Taken by Chris Morgan on Geograph, 2015. Licensed under [CC BY-SA 2.0](https://www.geograph.org.uk/photo/4448537). Available: <https://www.geograph.org.uk/photo/4448537>In sulator Sets

D.2.3 Insulator sets

Insulator sets are used to maintain internal clearances and insulation levels between live and earthed parts. They are composed of an insulating material and metal fittings that connect to the structure and hold the conductor at the live end. Their length and dimensions depend mainly on the voltage of the line, the over-voltages which the line is to be protected against (insulation strength and coordination), and the creepage distance which relates to the pollution level of the area. There are three main varieties of insulating materials for transmission line insulators: glass, porcelain and composite. Glass and porcelain insulator sets comprise of multiple standard design sheds; an example of which can be seen in Figure D.3 a). Composite insulators are single pieces of a set length made from a glass fibre reinforced resin rod housed by a silicon rubber or similar, Figure D.3 b). There are two types of insulators depending on their function: suspension and tension. Suspension insulators are used in suspension towers

and they usually hang vertically as illustrated in Figure D.2 a). Tension sets, on the other hand, are used in tension and terminal structures to cater for horizontal tension changes, as shown in Figure D.2 b) and c).

Figure D.3: Insulator sets: a) Glass type, b) Composite type

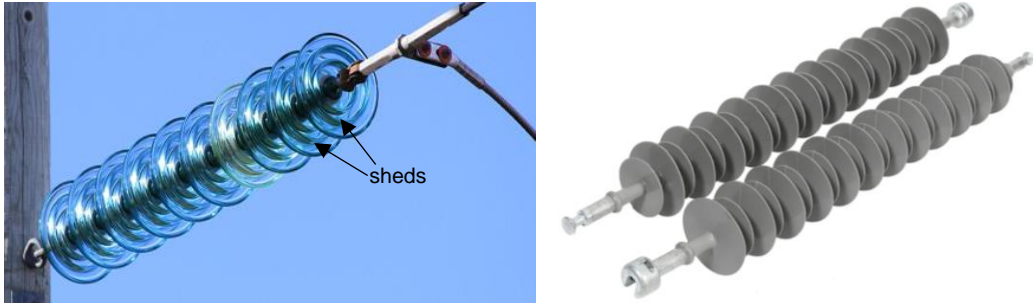

Source: a) "Insulators for OHL 35 kV. - 750 kV", ITG, 2013. Available: <http://www.itg.ge/insulators.html>

Source: b) "Suspension Insulator", Orient Tec Insulators, 2020. Available: www.powerinsulator.com

D.2.4 Foundations

Foundations are installed to transfer the structural loads from the tower/pole/pylon to the subsoil, to provide stability (uplift, overturning, sliding), as well as protecting the structure against critical movements of the subsoil. A range of foundation designs and techniques are commonly employed depending on the particular geotechnical parameters of the soil at the installation location (bearing capacity, settlements), water table level, potential seismic risk and chemical properties (aggressiveness of the soils).

Tower foundations in good to moderate soils normally employ shallow foundation types such as standard concrete pad and column (chimney) foundations like the one shown in Figure D.4.

Figure D.4: Typical pad and column foundation

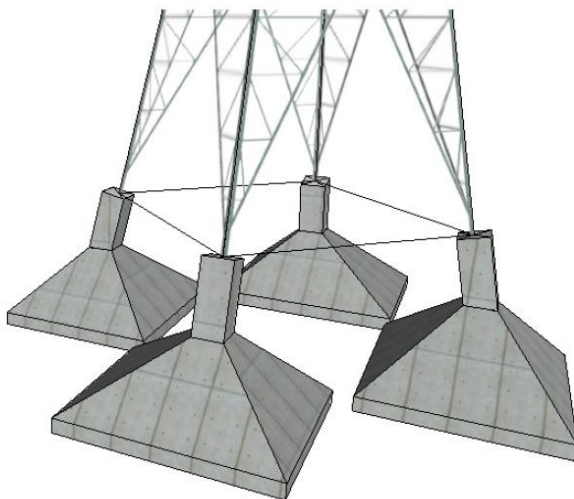

Source: Mott MacDonald

In rocky soils or where sound bedrock is near the surface, special techniques such as the use of explosives, or foundation types like rock anchor micropiles are in common use. An example of such a foundation type can be seen in Figure D.5.

Figure D.5: Typical rock anchor micropile foundation

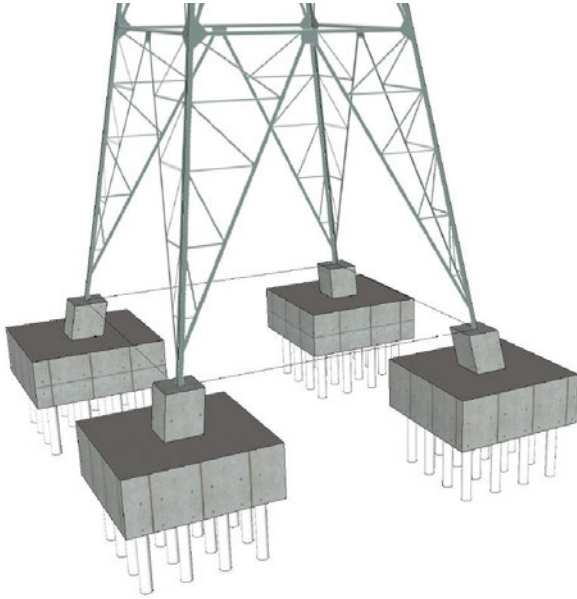

Source: Mott MacDonald

In contrast, when sound ground is not present in the upper levels of the subsoil, deep foundation types may be adopted, with an example being a piled foundation as indicated in Figure D.6.

Figure D.6: Typical piled foundation (raked type)

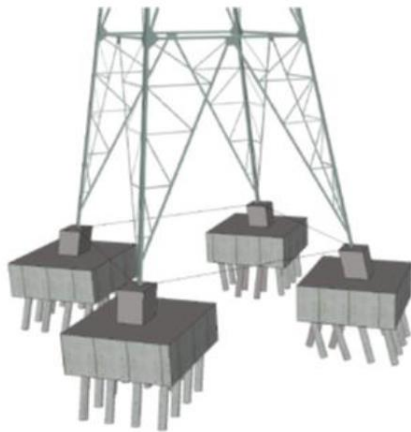

Source: Mott MacDonald

D.2.5 Earth Wires

Lightning strikes can generate millions of volts across line insulators which can lead to insulator tracking, punctures, and shed damage. They are one of the primary causes of transmission line outages, momentary interruptions, and reliability problems. For that reason, it is of paramount importance to protect lines' conductors against lightning strikes through the use of earth wires at the peak of the structures to shield the conductors.

Depending on the number of circuits and the disposition of the conductors this is done through the installation of one or two earth wires. They have similar characteristics to standard conductors but are usually smaller in dimension, and consist of only a single conductor as opposed to a bundle. They also tend to accommodate fibre optic wires to allow deployment of

telecommunication means. This arrangement is often known as an optical ground wire (OPGW); an example of this cable can be seen in Figure D.7 .

Figure D.7: Typical OPGW cable



Source: “HexaCore Optical Ground Wire (OPGW)”, AFL, 2022. Available: <https://www.aflglobal.com/emea/Products/Fiber-Optic-Cable/Aerial/OPGW/HexaCore-OPGW>
<https://www.ssen-transmission.co.uk/projects/project-map/dunoon/>

Figure D.8 shows a line with a single earth wire on the top of the tower.

Figure D.8: Overhead line with a single earthwire



Source: “News & Views – The latest updates from SSEN Transmission”, SSEN, 2023. Available: <https://www.ssen-transmission.co.uk/news/news--views/2022/11/argyll-overhead-line-project-reaches-major-milestone-with-over-half-of-new-towers-now-installed/>

D.2.6 Earthing

Earthing systems are designed to ensure the safety of the public by keeping step and touch voltages caused by fault currents to acceptable levels. They normally constitute a number of earth electrodes driven into the ground at each tower location, with the tower then being bonded to these electrodes. Other designs, make use of the steel reinforcement within the foundations to provide the earthing system, although such design is not followed in GB.

D.3 Overhead Line Construction

D.3.1 Pre-construction activities

Prior to construction, a Construction Environmental Management Plan (CEMP) is produced to outline how the construction project plans to avoid, minimise or mitigate the effects on the

community, wildlife, environment and surrounding area. Working areas, accesses and method statements are prepared, discussed and agreed with authorities, stakeholders and landowners.

Before the construction teams are fully mobilised, site information is collected to consider it in the design and in the method statements. Typical surveys carried out for OHL projects are the following ones:

- Third Party Searches: To identify all the known services within the study area.
- Topographical Survey: To collect data points of the ground and obstacles to incorporate them in the models to ensure statutory clearances are met.
- Access Survey: To identify possible access roads to the sites.
- Traffic Management Plan (TMP): It determines haulage routes, vehicle types and numbers required during construction to assess the effect on the local area, to develop mitigation measures to lessen the impact, and to facilitate the construction works.
- Scaffolding Survey: Scaffolding is required to protect members of the public and assets, and to enable the conductors to be safely recovered in the event of a failure. Preparation for access and land-take is required beforehand.
- Ground Investigation: To determine physical data and properties of the soil, including sub soil and strata. This information is used to determine towers' foundation types and access to site.
- Soil Management: To establish the procedure to manage the temporary removal and storage of topsoil and subsoil until earthworks are completed.

D.3.2 Site Set-up and Mobilisation

Before any works start on site, office and yard accommodation will be required. It is common that both office and yard to be situated at one location, close to where the works will be taking place. The office accommodation may consist of an existing building with all adequate facilities built in, or alternatively there may be the need to provide a number of temporary portable offices.

A small area of hard standing is required for the storage of materials, plant and equipment. Portable generators may be required to provide power to the offices and the site yard, as well as temporary arrangements for fresh water and sewage being needed.

D.3.3 Access, Construction Lay-down Areas and Site Security

This will involve the construction of temporary access roads, upgrading existing roads or using specialist equipment to access the construction site. The area will be demarcated and cleared to keep livestock and the public away from the construction activities. The TMP states the number and frequency of delivery vehicles accessing these areas.

In order for construction traffic to enter the land at each structure location, a suitable access point off the local highway needs to be constructed. Figure D.9 presents a typical bellmouth design.

Figure D.9: Plan view of a typical bellmouth design

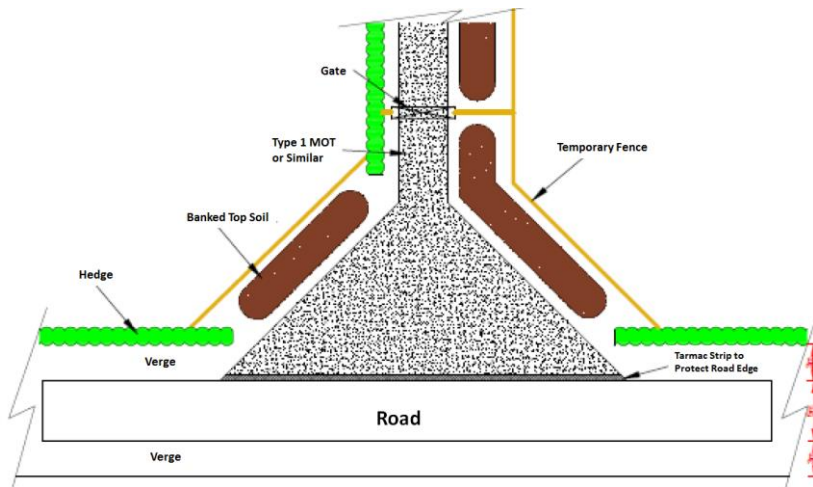

Source: Mott MacDonald

To access structure locations 4 m wide roads are typically used. When possible, existing access roads are used and sometimes they require some upgrading beforehand. It is sometimes necessary to cross a drainage ditch or watercourse to access a particular work location and a culvert is typically installed in this situation.

Around each structure location a working area is established, and this typically includes a stone pad or mat to cater for loads imposed by vehicles, machinery and construction activities.

Fencing is used where it is required to demarcate work areas and restrict access from livestock and the public.

Prior to commencement of construction it may be necessary to undertake right of way (ROW) clearance. This involves removing vegetation from the overhead line route to obtain sufficient space to construct the overhead line. The width of the clearance varies depending on a number of factors including the design of the line and the surrounding area, but indicatively could be up to around 50m for a typical 400 kV tower. Depending on the nature of the terrain, ROW clearance may not be required.

D.3.4 Scaffolding

Scaffolds are erected in preparation for the stringing operation, to protect roads, tracks, paths, railways, hedgerows or overhead lines from the accidental dropping of conductors or line fittings. They are typically erected before either conductor or earth wire is pulled between structures.

Figure D.10: Scaffold protecting railway line



Source: "Line Crossings | Netting & Protection", Brand Energy & Infrastructure Services, 2023. Available: <https://www.beis.com/uk/services/total-industrial-access/line-crossing>

D.3.5 Foundations

For the installation of foundations, the machinery and method statement employed depend on the type of foundation, access and soil type. A description of the main foundation design types is provided in D.2.4.

Towers are set out and pegged prior to excavation as shown in Figure D.11 .

Figure D.11: Foundation setting template



Source: "Environmental Impact Statement", Vol 3B Ch7, Eirgrid Group, 2015. Available: <https://www.eirgridgroup.com/app-sites/nsip/docs/en/environmental-documents/volume-3b/main-doc/Volume%203B%20Chapter%207%20Construction.pdf>

In GB, transmission lines are normally constructed using four-legged steel lattice towers which use individual footings for each tower leg. Pad and chimney is the most common design type and rubber tyre or tracked excavators are used for their excavations. An example of this foundation type can be seen in Figure D.12.

Figure D.12: Pad and chimney foundation



Source: "The Difference Between Footing and Foundation", TR Construction, Jul. 2021. Available: <https://trconcreteconstructionomaha.com/difference-footing-foundation/>

In areas of poor ground and high-water table, sheet piles supported by hydraulic frames are commonly used to prevent collapse of the sides.

Concrete trucks are normally used to pour the concrete directly into the excavation. When access does not allow this method, dumpers fitted with concrete chutes are usually employed.

Pile foundations are required when there is no presence of sound ground in the upper levels of the subsoil. In such cases, long concrete piles are driven into the ground and, when there is more than one pile per leg, they are encapsulated into a cap. The piles can be constructed using steel tubes in which concrete is poured or by means of pre-cast concrete.

Another alternative that is sometimes considered a pile foundation is the augured concrete foundation, which is suitable for stable soils as they require to be augered by drilling rigs as shown in Figure E.13.

Figure D.13: Excavation for augured foundation



Source: "Helical Piles vs Concrete Drilled Shafts (Caissons)", Hubbell, 2021. Available: <https://blog.hubbell.com/en/chancefoundationsolutions/helical-piles-vs-concrete-drilled-shafts-caissons>

D.3.6 Tower assembly and erection

Steelwork is delivered from central depots to site in preparation for assembly. Deliveries are usually done by articulated lorries or by trucks with hydraulic crane mounted on the rear to allow the steelwork to be off loaded on site.

To assist with the tower assembly and the lifting and moving of steelwork around the site, it is usual for the operatives to use a tractor with a mounted crane or a telehandler. The telehandler can be used to erect towers' sections, especially the lowest ones.

A lifting plan documents the process for lifting all the assembled steelwork. It identifies where the crane will access and be positioned on the site, the weight, size and position of each assembled section to be lifted, the order of the lifting of the sections, and who will control the operation. The lifting plan will identify all the hazards on the site and the mitigating measures put in place to minimise the risks. Hazards can be in many forms, and control measures may include height and weight restrictions, slew restrictors (restricting the swing of the crane), wind speed limits etc.

Figure D.14: Crane erecting tower sections



Source: "In Pictures: New lattice pylons erected near Shurton", National Grid, Jan. 2022. Available: <https://www.nationalgrid.com/electricity-transmission/hinkley-connection/news/pictures-new-lattice-pylons-erected-near-shurton>

In constrained locations or where access is very difficult, other erection methods can be used such as the use of helicopters or gin/derrick poles in combination with winches/tractors; an example of the latter technique is shown in Figure D.15 .

Figure D.15: Erection using derrick pole



Source: "Tower Erection", Tesmec, 2023. Available: <https://www.tesmec.com/stringing/equipment/tower-erection>

D.3.7 Stringing

This is the phase of works where the conductors and earthwires are installed. This is usually done in sections between tension structures. Layouts, like the one in Figure D.16, are developed in advance to clearly identify the different stage by stages and method statements of the stringing works.

Figure D.16: Generic stringing layout

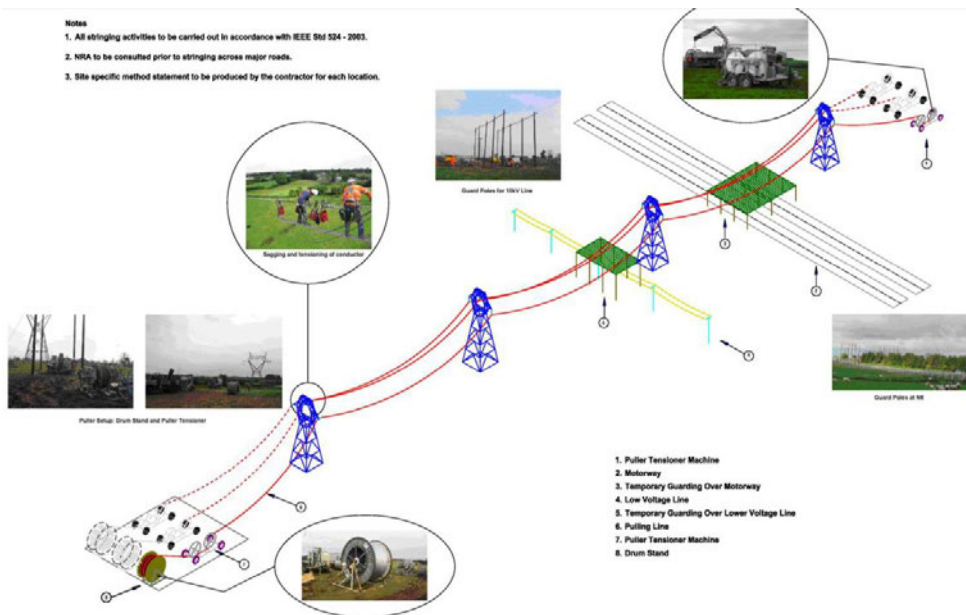

Source: "Environmental Impact Statement", Vol 3B Ch7, Eirgrid Group, 2015. Available: [https://www.eirgridgroup.com/app/sites/nsip/docs/en/environmental-documents/volume-3b/main-doc/Volume%203B%20Ch apter%207%20Construction.pdf](https://www.eirgridgroup.com/app/sites/nsip/docs/en/environmental-documents/volume-3b/main-doc/Volume%203B%20Ch%20apter%207%20Construction.pdf)

Firstly, pilot wires are run out at ground level (and over temporary scaffolding protecting obstacles, roads, etc.) along the full length of the section, between the pulling site and the tensioning site where the new conductor is positioned. The pilot wires are fed through running-out blocks (large wheels to enable the conductors to travel freely) on the cross-arms of all the structures and then, at both section ends, connected to stringing machines at the pulling and tensioning sites.

Figure D.17: Stringing site during T-pylon line construction



Source: "In your area", National Grid ET, 2023. Available: <https://www.nationalgrid.com/electricity-transmission/network-and-infrastructure/hinkley-connection/in-your-area>

The pulling machine is situated at one end of the section, and this will pull the new conductor. At the other end, sit the drums of the new conductor and the tensioner, which supports the puller during the stringing by adjusting the tension.

Pulling and tensioning sites require the installation of Equipotential Zones (EPZs) to provide protection to personnel from the effects of potential differences that could arise during stringing activities. The EPZ consists of a mat of linked conducting metal panels, on which all the stringing equipment and machinery will sit. They are then electrically bonded together to a common point, with an earthing bus welded onto one of the panels.

D.3.8 Re-instatement

Once the construction works have been completed, re-instatement of all the structure sites and temporary accesses take place. Reinstatement activities mitigate for the intrusive works that occur during the project. Additional environmental enhancement works may also be carried out. Reinstatement is agreed with grantors and key stakeholders and they typically comprise:

- Replanting of hedgerows.
- Replanting of woodland.
- Natural regeneration.
- Enhancement planting.
- Reinstatement of hedge banks.
- Seeding.
- Replacement of any topsoil stripped.

D.4 Overhead Line Maintenance and End of Life Considerations

Overhead lines are exposed to the elements and, although designed for such a situation, require regular maintenance. The following are examples of maintenance activities which will need to be undertaken periodically throughout an asset's lifetime.

Table D.1 Transmission line maintenance activities

Item	Description
Vegetation Clearance	<ul style="list-style-type: none"> ● Tree cutting and other vegetation clearance must be carried out regularly along the route to ensure statutory clearances are maintained.
Route Inspections and Condition Monitoring	<ul style="list-style-type: none"> ● Route inspections can be undertaken either from ground level, or using a helicopter, or more recently also unmanned aerial vehicles (commonly referred to as drones). ● Helicopter and drone inspections usually include techniques such as thermal imaging to detect “hot spots” on the line. ● Common conductor tests (eddy current technology to estimate remaining thickness of zinc or aluminium on the steel core). ● The purpose is to check for obvious defects such as damage to insulators, clearance issues and other similar matters.
Maintenance of towers	<ul style="list-style-type: none"> ● Tower inspections to verify condition of the steelwork and potential corrosion issues. ● Towers may need to be painted, some parts may need to be replaced, or additional steelwork may be added for strengthening purposes. ● Integrity of foundations and earthing systems will be checked. ● Integrity of signage and anti-climbing devices will be checked and, if necessary, replaced.
Maintenance of fixtures and fittings	<ul style="list-style-type: none"> ● Period maintenance of fixtures and fittings may be required. ● This may include either cleaning or replacement of insulators and other components.

Once overhead lines have reached the end of their useful life there are several options available for consideration as explained below:

Table D.2: Overhead line end of life considerations

Item	Description
Dismantlement	<ul style="list-style-type: none"> ● This option is not undertaken frequently as it is generally the case that the transmission capacity provided by the circuit is still required. ● In some situations dismantlement is undertaken for other reasons such as to improve an area visually. ● In the case of dismantlement all above ground equipment is removed and recycled so far as possible. ● Foundations will usually not be removed in their entirety due to the significant environmental impact this would have, but are instead reduced to a suitable distance below ground level.
Conductor replacement	<ul style="list-style-type: none"> ● Instead of dismantlement it is more common for the existing route to be re-used by removal and replacement of some components, primarily the conductors and fixtures and fittings. ● Generally the towers and foundations can be re-used following condition assessment, although some maintenance and/or strengthening may be required.
Upgrade of the overhead line	<ul style="list-style-type: none"> ● At the end of a transmission line’s life, consideration can be given to upgrading it using techniques mentioned in Sections D.2 and D.6. ● For example, it may be possible to upgrade the line to a higher voltage, or use a different type of conductor, to provide greater capacity.

D.5 Application of the Technology

Overhead lines have proved to be the most reliable and cost-effective means to design, build and operate transmission networks. For that reason, they are still generally the main technology employed globally for such purposes. They provide a reliable and robust infrastructure which generally responds to incidents returning to normal operation in seconds; and even when they are physically damaged, their repair can normally be accomplished within hours.

Overhead lines are typically also the fastest and the least costly method to procure and construct a transmission connection. However, in recent decades the deployment of new lines has faced significant opposition from the public in many countries, including GB. The principal limitations of overhead lines relate to their space requirements, the public's resistance to their visual appearance, and concerns around electric and magnetic fields³³. As a consequence, in the last two or three decades public scrutiny has made the planning process of routing new overhead lines increasingly complex and lengthy in GB.

The next section presents some alternatives to the traditional methodology to design and build transmission lines in GB. Some of them are already mature technologies being implemented across multiple projects, while others are mature technologies in other networks or countries, which could present potential opportunities in the long term.

D.6 Alternative Overhead Line Approaches and Anticipated Future Developments

D.6.1 Hot Wiring

The term hot wiring refers to operating a conductor above the maximum operating temperature for which the line was originally designed. Common maximum operating temperatures of ACSR and AAAC conductors in GB are 75 °C and 90 °C respectively. In GB lines have commonly been designed to meet the desired ratings at lower temperatures such as 50 °C. Therefore an assessment of the line can be undertaken to determine whether it can be operated at a higher temperature (and therefore higher current) under certain circumstances, without compromising its integrity. Increasing the conductor's temperature translates physically into greater sags; therefore, when this solution is studied the first thing to satisfy is that statutory clearances to ground and obstacles are met. When required, some mechanical compensations can be implemented to compensate the sag increase, but in any case this method typically only provides a small increase in the capacity of the line, in the region of 3% for every 5 °C increment. Therefore its effectiveness is limited to an ad-hoc project-specific solution when certain circumstances are met.

D.6.2 High Temperature Low Sag Conductors (HTLS)

In the last 15 – 20 years HTLS conductors have entered the overhead line market. GB has one of the most experienced networks in the use of this technology as it was introduced in the early 2000s.

These conductors provide superior mechanical and thermal capabilities by introducing additional materials to the conductor. Compared to traditional conductors, HTLS can operate at much higher temperatures (150 °C – 210 °C), with null or minimal increase in the sag. This means that HTLS of similar dimensions and weight to traditional conductors exert very similar loadings on structures and foundations requiring no or minimal strengthening of the existing structures and maintaining the statutory clearances. The current rating increase achieved with these conductors is in the region of 40% - 100% of the capacity of a traditional conductor of similar dimensions.

The most popular HTLS types are the following ones:

- Thermal Aluminium Conductor Steel Reinforced (TACSR).
- Aluminium Conductor Steel Supported (ACSS).

³³ For UK lines the occupational exposure limit follows the limits set out by ICNIRP (International Commission on Non-Ionizing Radiation Protection) 1998 and for public exposures abide by 1999 EU recommendation.

- Aluminium Conductor Composite Core (ACCC).
- Aluminium Conductor Composite Reinforced (ACCR).
- Aluminium Conductor Polymer Reinforced (ACPR).
- In GB, the most used HTLS conductor has been G(Z)TACSR, also called GAP, which consists of a variant of TACSR by the immersion of a small gap filled with temperature resistant grease surrounding the high strength steel and the use of trapezoidal super thermal resistant aluminium alloy wires in the outer layers.

Figure D.18: Cross section of GAP conductor

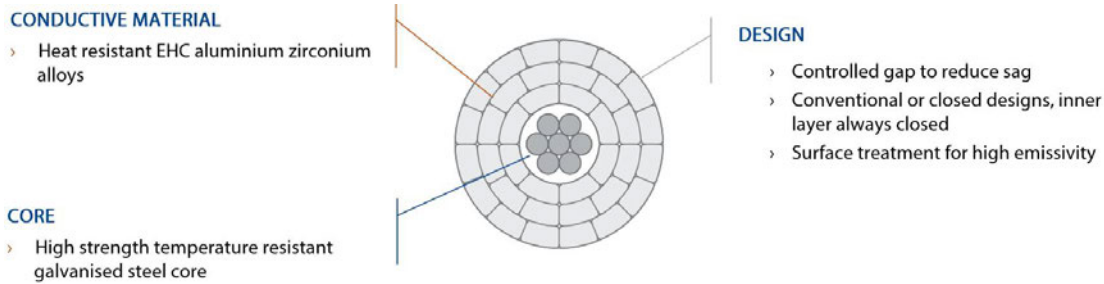

Source : "GAP+", Lamifil, 2023. Available : <https://lamifil.be/overhead-conductors/gap/>

- Figure D.19 presents typical sag-tension characteristics for a GAP conductor versus a traditional AAAC conductor. As can be seen, the GAP conductor can operate at 1,650 A current with less sag and similar tensions as compared to the traditional AAAC type of conductor operating at 1,100 A current.

Figure D.19: Typical sag-tension characteristics of GAP versus AAAC

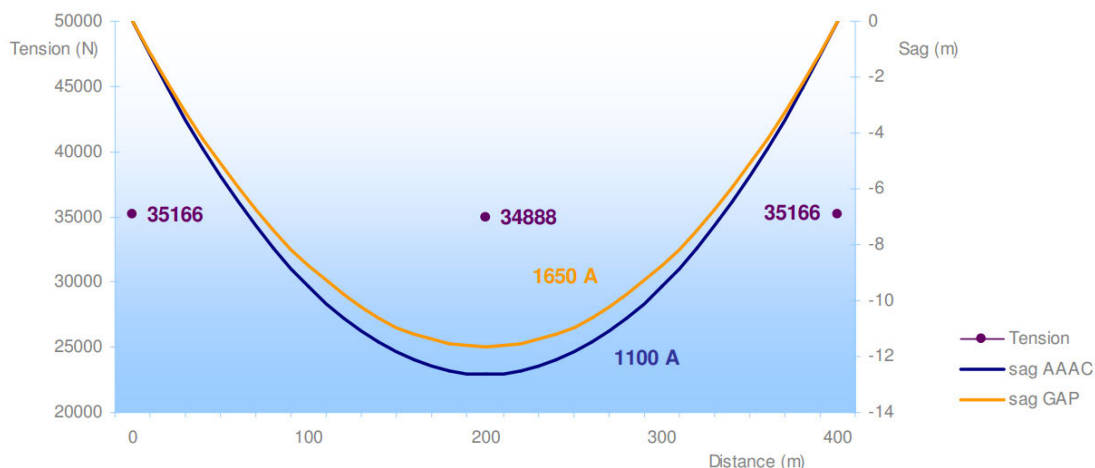

Source: "The improved GAP conductor", Lamifil, May. 2011. Available: https://lamifil.be/wp-content/uploads/2011/05/GZTACSR_NG1.pdf

ACCC and ACCR have also entered the market more recently in GB and have been used across multiple uprating projects. These two conductor types benefit from a fibre-reinforced metal matrix core with much lower coefficient of thermal expansion compared to steel or aluminium. They also provide higher current-carrying capabilities (the ACCC thanks to their fully annealed aluminium wires and the ACCR with aluminium-zirconium alloy wires). A cross section of the ACCR conductor can be seen in Figure D.20.

Figure D.20: Cross section of ACCR conductor

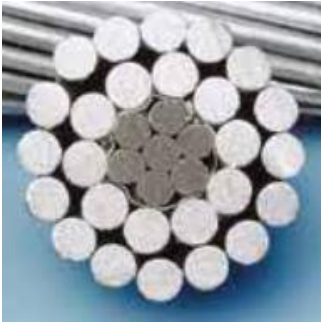

Source: "Protecting Grid Integrity- More amps, more confidence", 3m, 2014. Available :
<https://multimedia.3m.com/mws/media/4782700/3m-accr-technical-summary-english-units.pdf>

The stringing of HTLS conductors is more complicated and requires some special fittings and knowledge on their manipulation either by experienced contractors or by supervision of suppliers. The mechanical strength of HTLS normally relies completely on a high strength core which requires that during their installation all tension is applied to the core on which a special dead-end clamp is compressed. The outer layers, which provide the high current capacity, are left hanging on the core as a dead weight during a settlement period (a few hours or a day), after which, they are compressed over the conductor and the core.

Reconductoring by using HTLS conductors has proved to be an efficient method to increase the rating of existing OHLs with low CAPEX cost and a significantly simplified planning process. Even if these conductors are significantly costlier than traditional ones (in the range of 40% - 110% higher), provided they can achieve the target rating, their use is normally well justified when compared to the costs of new OHLs; for further information on this please refer to Section 4. However, the line to be reconducted would need to be subjected to an engineering assessment to confirm its suitability for the new conductor and fittings.

Whilst these conductors have been in use since the early 2000s in GB, there is still some lack of documented experience and a complete set of internationally accepted standards and recommendations as compared to traditional conductors. In addition, the long-term and ageing effects of these conductors and their hardware and fittings have yet to be verified and fully proven too once they have remained in operation for decades (traditional conductors have a lifespan of approximately 40 years with a proper maintenance routine). However, the experience to date is generally good and all products being used have been through vigorous quality assurance processes, with the expectation of successful long-term results.

Due to the continuous pressure on demand, operational constraints and the public's reluctance for new lines, reconductoring by using HTLS conductors has become the most common uprating alternative for OHLs, and it is anticipated that this will remain the case in the near future.

D.6.3 Alternative Insulating Techniques

In the GB transmission network the majority of lines, especially at 400 kV, have been designed using steel lattice towers that possess steel cross-arms to provide the statutory clearance between live parts and the tower body, with the insulator sets attached to the cross-arms, as shown in Figure D.1. However, some designs use the insulators to provide such a physical distance, which is quite common on poles in other countries. An example of this can be seen in Figure D.21.

Figure D.21: 400 kV OHL Mushrif-Nahda in Dubai, UAE



Source: Mott MacDonald

This line design demands that the insulators can withstand cantilever or compression loads, or a combination of the two, which is more onerous than the traditional tower design in which the insulator works at tension only. For this reason, composite post and braced post insulators need to be used with such a design.

Using non-swinging insulated cross-arms allows the line to reduce its height and footprint; for an explanation of their use in compact lines please see Section D.6.4. The following figure illustrates the different concept of this design compared to the traditional suspended insulators.

Figure D.22: Suspension insulator versus insulated cross-arm

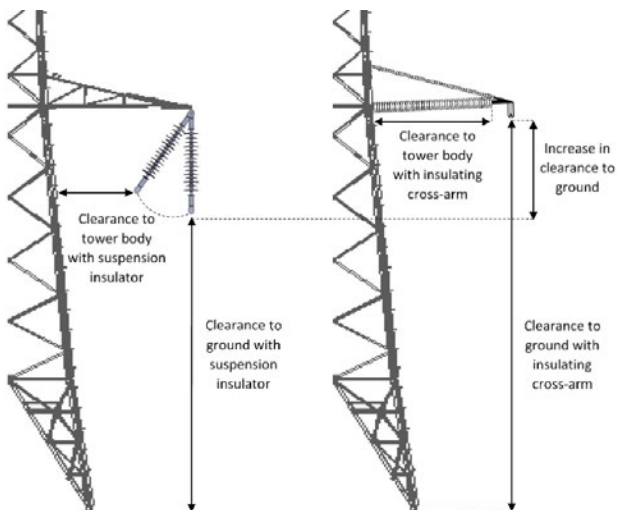

Source: "Welcome to the RICA Project", National Grid, 2020. Available: <https://www.nationalgrid.com/electricity-transmission/innovation/rica>

The use of insulated cross-arms can therefore reduce the footprint of the line and increase the clearance to the ground. This alternative can provide more compact designs for new lines, as

explained in Section D.6.4, or an additional option to upgrading existing lines through voltage increase and/or reconductoring as explained in Sections D.6.5 and D.6.2 respectively. Insulated cross-arms technology has been tested in GB, for more details please refer to Section D.6.5.

D.6.4 Compact Lines

A line is considered to be compact when the distances between phases are much less than those used in conventional designs. An example of this can be seen in Figure D.21. Most recently in GB, NGET has energised its “T-Pylon” overhead line, which is a type of compact line. This is shown in Figure E.25 and described later in this chapter.

Compact lines have the following advantages over conventional lines:

- Reduced width of right of way, thus potentially reducing costs associated with land agreements and vegetation clearance.
- Due to the phase-to-phase distance reduction there is an increase in power flow as a result of the reduced inductive reactance and the increased capacitive reactance.
- Reduction in power losses.
- Decrease of electric and magnetic fields.

In some instances they can also be considered to have a lower visual impact. However, this is highly situational dependent and not always the case.

On the other hand, reducing the distance between phases presents some technical challenges mainly due to the increase of the corona gradient, and subsequently audible noise and radio interference, and the electric and magnetic fields (EMF) at ground level. Multiple parameters need to be considered in the electrical design of a compact line to mitigate these with key aspects as follows:

- Number of sub-conductors in the bundle. Once the separation between phases is fixed, the number of sub-conductors is the main parameter to consider. The more sub-conductors the bundle has, the lower the corona voltage gradient and EMF are. The reduction of sub-conductor spacing can also provide some mitigation although is less critical.
- The use of trapezoidal stranded conductors, rather than the conventional round stranded conductors, provide some mitigation in respect of the surface gradient of the conductors.
- Increase of the height of the conductors above ground. This has a significant effect in EMF at ground level but results only in a slight reduction of corona, audible noise and radio interference.

Insulation strength and coordination is a crucial factor in the design of any overhead line. The reduction in the separation between phases needs to be considered in the line design against over-voltages. Some non-conventional designs have been implemented to maximise the reduction of the phase separation while ensuring insulation coordination is not compromised.

For example, in suburban areas in Norway where there were concerns about magnetic fields produced by 300 kV and 420 kV lines, an innovative design has been used. This design has no earth wire and uses surge arrestors to protect against lightning over-voltages. Figure D.23 a) presents a tower with the surge arrestor installed. In respect of insulators, compact lines tend to use composite and/or alternating shed designs which can achieve the same creepage as a conventional line using smaller sets. As explained in D.6.3, the insulators can also provide the physical means to obtain the clearances to earthed parts and therefore are commonly used in compact lines. Wind-gusts or galloping can significantly reduce the distance between phases which can lead to phase-to-phase flashovers issues. Several devices can be installed to mitigate these problems, with inter-phase spacers being the most widely used in compact lines. This device is composed of two insulators, one at each end, and a middle section that allows

adjustment of the overall length to the required distance. Figure D.23 b) presents an example of this device.

Figure D.23: a) 420 kV line in Norway, b) Inter-phase spacers



Source: a), b) Reprinted with permission from CIGRE, Compact AC Overhead Lines, Technical Brochure 792, © 2020.

Compact lines present the challenge of reduced phase-to-phase separation when live line maintenance is required. To obtain safety distances, compact lines sometimes require further mitigation measures compared to traditional lines, or at least implementation more frequently. As such, a comparison may show a traditional OHL having a better performance in this respect. However, the main advantages of compact lines are the reduced footprint required and the reduced visual impact so they might prove in the future a viable option in some cases where a traditional OHL would not receive consents. In such instances it is likely that a compact OHL will be more cost effective as compared to an underground cable.

There are multiple possible options for the structures and configurations of compact lines. The designs which are similar to traditional configurations with lattice towers or poles, tend to use insulated crossarms, as explained above, or V-strings to impede the insulator swinging. An example of poles with insulated cross-arms can be seen in Figure D.21 and a multi-circuit steel lattice tower with V-strings can be seen in Figure D.24 a). Some designs of compact lines have been quite innovative with no structural element between phases; an example of which is presented in Figure D.24 b).

Figure D.24: a) 420 kV line with V-strings, b) 380 kV line in Italy



Source: a) Reprinted with permission from CIGRE, Compact AC Overhead Lines, Technical Brochure 792, © 2020.

Source: b) "ENEL Power Pylons", Foster+Partners, 2023. Accesible: <https://www.fosterandpartners.com/projects/enel-power-pylons/>

In GB, an innovative design at High Voltage is the T-pylon recently developed by National Grid. An example of this structure can be seen in Figure D.25.

Figure D.25 : National Grid's T-pylon



Source: "What is a Pylon", National Grid, 2023. Accesible: <https://www.nationalgrid.com/stories/energy-explained/what-is-a-pylon>

This multiple award-winning design reduces the height by approximately 30% compared to traditional lattice towers. The innovative design utilises double circuit single poles that hold each circuit and its earth wire in a diamond 'earring' shape using a single attachment point. The number of structural components in this design is reduced compared to traditional lattice towers and therefore it is expected that a T-pylon could be erected faster than a comparable steel lattice tower, although we understand that a larger crane is required for assembly leading to increased temporary works. T-pylons are not suitable for installation in all terrains and their ability to improve visual appearance and reduce environmental impact is highly dependent on

the context within which they are deployed. As they cannot be climbed, the design must consider how suitable access equipment can reach the tower locations during the operations phase which could lead to their application being unfeasible in areas of difficult terrain, from both a construction and operation and maintenance perspective. They are also less adaptable to different terrain as they cannot achieve such tight turning angles. Overall there is a greater steel content and, based on the data we have received, T-pylons are in the region of 1.5 to 2.5 the cost of traditional lattice tower OHLs. As this is a new design, the cost differential could reduce as more lines are constructed using this technique.

Overall we expect compact lines to be used where visual amenity factors are a key project driver, but where the installation of an underground cable may either be cost-prohibitive, impractical, or may not meet the network need (for example, due to insufficient rating). Compact lines tend to face less resistance from the general public. At the moment in GB the only use of compact lines is the T-pylon design, and this is now operational. Therefore, compact lines have the potential to become a more common solution in the transmission networks of GB but it is not yet a mature technology and will need years of experience to develop a more streamlined design, procurement, construction and operation process.

D.6.5 Voltage Up-rating

In addition to increasing the current, the other main option for increasing the power transferred by a line is to use a higher voltage level. This methodology has proved to be, in general, more difficult to implement, as it tends to have a greater impact in the design of the line. A higher voltage means greater clearance requirements. As per TO specifications, a nominal voltage change from 275 kV to 400 kV prompts the following increase in the clearance requirements:

- Between conductors and ground or road surfaces: 0.6 m – 0.7 m.
- Between phases: 1.2 m.
- Between live and earthed parts at the tower: 0.4 m.

The external clearance to ground and obstacles can be mitigated by the design modifications listed in Section D.6.1, or by the use of HTLS conductors. However, internal clearances, and particularly live-to-earth clearances at insulator sets and from jumpers to tower, tend to be more difficult to resolve as margins are smaller.

One of the most common methods to overcome this issue in recent years has been the replacement of the steel cross-arms by retrofitting insulated cross-arms as explained in Section D.6.3. This method reduces the required electrical footprint and can be used to increase the line voltage without major modifications on the structures. However, the use of these insulators in steel lattice towers brings some fundamental design changes that need to be considered. The load transfer between conductor, insulator and cross-arm is modified, compared to a traditional tower design, and there is a lack of standardisation with several design types available in the market. Design modifications result in changes in the dynamics of wind induced vibrations and galloping; phenomena that are mitigated by dampers and tension limits which are well proven through decades of use. In addition, the use of these insulators prompts a decrease in the vertical distance between conductors and earth wires which results in a reduction of the shielding angle which protects against lightning strikes.

When voltage up-rating to 220 kV or above, one of the first factors to verify is the corona inception. If the conductor's cross section needs to be larger to deal with this issue, bundle options with lighter and smaller conductors could be studied but one of the main goals of an OHL up-rating project is to minimise as much as possible any strengthening of the structures or the foundations. This means in practice that voltage up-rating as a solution needs to be assessed case by case.

In addition to the design changes described above, safe working procedures for construction and maintenance will need to be established, tested and trained.

Voltage uprating has been used in multiple projects around the globe and, as an example, Statnett in Norway is in the process of converting most of its 300 kV lines to 420 kV.

In GB, the retrofit of towers with insulated cross-arms has been tested by SSE and NGET in several innovation projects. NGET is currently running the RICA (Retro-Insulated Cross-Arm) competition research project to develop an innovative method for uprating tower lines from 275 kV to 400 kV.

We consider that this method presents a feasible and realistic alternative for increasing the capacity of some OHLs; however it cannot yet be considered as a mature technology due to the multiple changes involved. In the GB transmission system, we consider it would be deployed to upgrade a line from 132 kV to 275 kV, 275 kV to 400 kV or even from 132 kV to 400 kV, and as such its effectiveness would be limited to such situations. As the highest nominal voltage in the GB system is 400 kV, this technique is not applicable at lines already operating at 400 kV.

D.6.6 Ultra High Voltage (UHV) Transmission

UHVAC and HVDC are generally used for large power transfers along long routes to reduce the electrical losses along the line. OHLs at these voltage levels are not very common and are mostly used in large countries such as Russia, Ukraine and China.

These lines tend to be single circuit with conductors placed in flat configuration and structures sometimes made of more than one body and/or supported by guy wires to optimise the amount of steel required. Figure D.26 presents a 750 kV line with a suspension structure at the forefront and an angle one, composed of three different structures, in the background.

Figure D.26: 750 kV Zaporizhzhia NPP – Kakhovska OHL, Ukraine



Source: Mott MacDonald

The physics behind these lines does not differ much from common transmission voltages such as 400 kV. However, the implications in their electrical design and operation are greater. For example, conductor bundles need to be larger using more conductors per phase to reduce the

corona gradient generated at conductors' surfaces to acceptable levels. In addition, electric fields are far greater, which results in larger corridor footprints.

The materials employed in these lines are the same as in 400 kV lines with the exception of insulators, arcing devices and fittings that need to be designed to manage the large electrical stress derived from these voltage levels.

The operation of lines at UHV levels brings several benefits to transmission networks. In addition to the power capacity increase in the circuit, it also allows for a reduction in electrical losses, lower voltage drop and greater stability.

As to construction activities, erection and stringing per km become more labour and machinery intensive due to the larger and heavier equipment involved, such as conductor system and insulator sets.

UHV lines are a mature transmission technology well established with many decades of successful operation in multiple countries, and are an economical method of achieving large power flows over significant distances. In the UK as in most countries, transmission operators have always opted for lower voltages for the expansion of their networks. One reason for this is that sources of load and generation have typically been distributed across the country, meaning that bulk point-to-point power transfer has not been necessary. Further, such lines are likely to be economical in situations involving very long distances, but GB is not a vast country and as such has not had the need for this in the past. However, UHV lines could in theory become an option to transmit large capacities along long distances; for example, they could run from Scotland, where generation is expanding rapidly, to the south of England where large consuming nodes are located. Deciding to introduce such a high voltage would require extensive preparation and master planning and would introduce fundamental changes to the way in which the system is operated (e.g. safety distances for maintenance, protection system design, EMF etc.). Further, the TOs do not currently have specifications, design standards or other documentation for operating at this voltage level. It is also likely that construction of such an overhead line would face significant challenges from a planning perspective. It is therefore not considered as a realistic technology for deployment within the GB network in the medium term. However, Section 4 does present an indicative cost estimate for implementation of such a solution, for consideration against other technologies presented.

D.6.7 High Voltage Direct Current (HVDC)

In the OHL domain, HVDC offers distinct economic and performance advantages over HVAC for long-distance transmission and, in addition, it also offers better power flow control compared to HVAC. Such matters are discussed in more detail in Appendix G. Moreover, the magnetic fields and the electro-static and electro-magnetic coupling characteristics of HVDC lines perform better than their HVAC equivalent.

However, HVDC presents some challenges that are less relevant or nearly inexistent in HVAC. Electric fields produced by HVDC lines are composed of not only an electrostatic field but also the ground current density and the maximum space-charge enhanced field that ionises the air due to the corona effect, which are negligible in HVAC fields. Audible noise is also a greater concern in HVDC lines, and it is a key design parameter in the selection of conductor bundles.

The materials employed in HVDC lines are the same as in 400 kV lines with the exception of insulators, arcing devices and fittings that need to be designed to manage larger electrical stress.

In recent years in GB, multiple converter stations are under construction or development as part of the HVDC offshore cable links to other transmission systems, to connect offshore windfarms, or to provide "embedded links" to reinforce the onshore network. It is not typical for such HVDC

links to include overhead line sections, as they are primarily located offshore using submarine cables. The distance from the shoreline to the converter station locations is typically quite short, and thus the fixed cost which would be associated with transitioning from an underground cable to an overhead line would not be economical for such short distances. However, the experience of construction and operation of these converter stations (together with the cost efficiencies achieved through developments in converter technology) provides a real opportunity to consider expanding the onshore network through HVDC OHLs. On the other hand, the construction of a submarine cable embedded link is likely to be seen as more favourable by the general public in comparison to an onshore HVDC OHL for visual impact reasons. Given that HVDC transmission is not economically attractive for short links (due to the high fixed cost of the converter stations), the long transmission distances may present challenges in respect of the selection/design of a purely overhead onshore route in GB.

HVDC lines are usually single circuit, but depending on the choice of HVDC technology used, it may be necessary to install several HVDC links to achieve the same rating as an equivalent HVAC OHL. This is discussed in more detail in Appendix G. An example of a HVDC overhead line is shown in Figure D.27. As can be seen, this line includes a single conductor bundle on each side of the tower, as compared to the three which are typically seen on each side of a HVAC tower.

Figure D.27: Western Alberta 500 kV transmission line



Source: "Western Alberta Transmission Line", Rokstad Power, 2022. Available: <https://rokstadpower.com/portfolio/watl/>

The use of LCC technology (which has higher current carrying capabilities as compared to VSC as explained in Appendix G) could be considered to transmit high levels of power over long distances. This technique could be comparable to the use of UHVAC transmission as described in Section D.6.6, and is in operation in several countries including China, Russia, India and Brazil, where large quantities of power need to be transmitted over long distances. Due to the use of very high voltages, typically up to 800 kV, overhead lines are employed as cables are not yet sufficiently developed to withstand such voltages. In GB, the application of this technology could be considered for similar reasons to using UHVAC such as a direct connection from Scotland to Southern England. For similar reasons as those stated for UHVAC transmission, we consider it unlikely to be deployed in the medium term, but have included a cost estimate for an indicative example in Section 4 for comparison purposes.

Another option for HVDC OHLs could be the conversion of existing HVAC circuits into HVDC. The two main challenges from a design point of view are again the corona surface gradient and the minimum clearance increase, especially between live and earthed parts along the insulator sets. Potential solutions to the corona issue could include increasing the quantity of conductors in each bundle, with a small overall loading increase, depending on the configuration.

For the same nominal voltage, the insulator set of an HVDC line needs to withstand a peak value approximately 22.5% higher than the HVAC line. Insulated cross-arms could present potential solutions to this challenge.

As an example of the applications of this technology, the Ultranet HVDC link in Germany is planning to convert one of the AC circuits of a 380 kV double circuit line into an HVDC circuit through retrofitting of only insulators in most of the sections.

The conversion of existing HVAC circuits into HVDC could present opportunities to increase the rating of circuits without extensive modifications in towers or foundations. However, detailed studies would need to be carried out to determine the most appropriate line configurations taking into account the multiple constraints of the existing lines, and also of the HVDC technology itself, such as the maximum current of valves on VSC converter stations.

D.6.8 Dynamic Line Rating

The maximum design current which can flow through an overhead line is calculated by assessing the heat gained and lost by the conductor under normal operation (steady state). The calculation is performed using location-specific weather assumptions, such as ambient temperature, absorptivity, and wind speed. Utilities have used conservative values for the weather parameters to ensure that the likelihood of a conductor exceeding its design maximum temperature under normal conditions remains very low. The most onerous weather conditions normally occur during summer and for this reason, utilities normally allow for higher ratings under same conductor temperature during colder months; but, in any case, the traditional rating approach is well known to be conservative.

The requirement for increased capacity on the NETS, and the difficulties faced in establishing new routes, have pushed utilities to search for innovative solutions that maximise the use of existing infrastructure. The Dynamic Line Rating (DLR) method seeks to increase the rating of existing lines when the weather conditions forecasted are more favourable than those assumed in the design. This involves placing monitoring equipment on the line, which provides real time feedback as inputs to algorithms in a server. In combination with weather forecast data, this can calculate the allowable current to consider in the dispatching.

Figure D.28: Typical DLR diagram

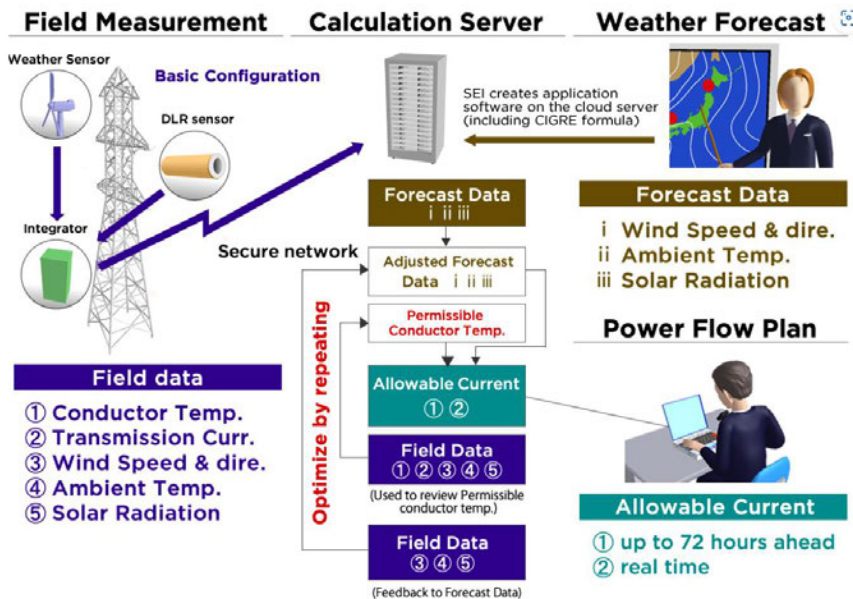

Source: “Dynamic Line Rating System”, Sumitomo Electric, 2023. Available: <https://global-sei.com/power-cable-business/products/dynamic-line-rating-system/>

Many DLR technologies are available, and they have experienced a significant development in the last decade due to the low cost of microelectronics, micro processing equipment and software interfaces. In general, there have been two main technology groups divided into monitoring either the conductor directly or predicting the weather parameters that affect the line rating. However, nowadays most devices combine both technologies.

In recent years DLR has evolved from being installed only in pilot tests to serving a multitude of operational lines in several countries. Some examples are as follows in Table E3.

Table D.3: Examples of DLR applications

Country	Description
Belgium	DLR devices have been used in at least 27 lines ranging from 70 kV to 400 kV. The technology employed uses real-time sag measurements combined with meteorological forecasting. The reliability of several models for weather forecast was analysed which concluded with the development of a methodology to allow for a lines' capacity gain with minimum impact to operational risks (increase not greater than 0.1%).
Slovenia	Slovenia is one of the DLR pioneers. At least 29 lines, of 110 kV, 220 kV or 400 kV have used these devices to increase their capacity. Monitoring is in place to obtain DLR calculations for all spans to track the weakest span that will determine the maximum rating along the whole line. The system supports real-time and short-term forecast operations, calculating capacities for up to two days ahead, and allows for mitigation against overloading, considering also abnormal running arrangements. It also features an inverse DLR algorithm for icing prevention and alarms for extreme weather conditions along the power lines.
Germany	DLR is being used in multiple heavy-loaded lines in Germany, and is integrated into most of the TSOs' dispatching centres.
UK	The following trials have been performed: <ul style="list-style-type: none"> Several trials were performed in the UK in the first half of the last decade by Central Networks (now part of WPD) in a 132 kV line, NIE in a 110 kV line, and WPD in three 11 kV lines. The trials identified significant average real time benefits; however this varied over a large range within a very short time frame largely driven by variations in wind speed. The conclusion was that the identified enhanced average levels could not be relied upon for extended periods of time due to the potential for changes in weather conditions.

Country	Description
	<ul style="list-style-type: none">● SSEN tested tension-monitoring devices in a 132kV line north of Dundee between 2015 and 2017 over a period of more than two years. The tension measurements were validated via physical ground line surveys and the manufacturer provided evidence that the circuit could be monitored at times above its present operational loading limits. However, it was concluded that to integrate the potential current increase onto the network more investigation was required.● In Q3 2022 National Grid started a two-year trial in the 275 kV line between Penwortham and Kirkby using non-contact monitoring systems.● SSEN has recently launched a scheme to supply and install DLR sensors and weather stations in 21 locations along the 275 kV Beaulieu – Dounreay Line. The DLR control system will provide a feed to the ESO's control room as a rating sheet to manage constraints on the network.

The maturity of this technology has increased in recent years, with multiple utilities already using it to support their operation of heavily loaded transmission lines. However, it is still early days for the models and algorithms that combine measured data with weather forecasting. To unlock the potential of this technology and to determine the level of capacity increase which it can provide, more experience is required in the treatment of the measurements and calculations and the integration of weather predictions.

The GB TOs and ESO are currently gaining knowledge of the technology through pilot tests. We would expect that a gradual implementation of this technology into operational lines could occur in the near or medium future (five to 15 years). There is a strong case for this technology being pursued, due to its potential benefits and low cost and easiness of implementation. In particular in GB it could be of relevance in areas that benefit from favourable weather conditions where strong wind gusts occur, and may alleviate congestion on overhead lines which are used for connection of wind-generation.

E. Underground and Submarine Cables

This section provides technical information on the use of underground cables on land as part of the GB NETS. Any explanation of submarine cables is also provided. Underground cables offer an alternative to overhead lines for transmission of electricity, and have been used for many decades as part of the GB NETS. They have a long established track record and owners, operators, installation and maintenance personnel are familiar with their characteristics. Submarine cables are used for connection of offshore generation, and as part of interconnectors or embedded HVDC links.

The purpose of this section of the report is to introduce some design, construction and operational aspects associated with underground and submarine cables, providing some context for comparison against other available technologies. The following topics are covered:

- A description of the technology.
- The components behind the technology.
- Maintenance and decommissioning.
- Works associated with installation.
- Its application and uses.
- Anticipated future development.

E.1 Technology Description

All forms of high voltage power transmission over long distances must have at least four main components:

1. one or more conductors to carry the electrical current;
 - a. single-phase systems require a phase conductor and a return.
 - b. three-phase systems typically require three conductors.
 - c. HVDC systems require a positive and a negative conductor, and sometimes a metallic return.
2. electrical insulation to maintain the conductor at a raised voltage level.
3. connections capable of combining lengths of manufactured conductor together for installation and or repairs.
4. conductor terminals or terminations which may be assembled on site and allow access to the conductor at the end of the connection. This access is required to send and receive the transmitted electrical current and apply the driving voltage.

The common performance requirements of electric power transmission over long distances are that the technology:

- is capable of being installed between remote points across the intervening terrain.
- can adjust to its surroundings so that it need not be installed in a straight line.
- is capable of being made safe in all areas where it is used, particularly those that are located in publicly accessible areas.
- must have a useful service life of several decades (a service life of 40 years is generally the default requirement for the GB transmission system).

Power cables meet all the requirements above and can also be routed in locations where overhead lines may not be permitted or feasible (e.g. offshore).

Power cables are typically installed directly in the ground (direct buried), or within ducts in the ground, and can also be installed in tunnels where necessary. There are other instances where cables are installed in troughs, basements or similar, but these do not generally form a significant part of the cable route and are not covered in this report.

The conductor of a power cable is typically made of aluminium or copper, with copper being more expensive but having a lower resistance per unit length and thus being more suitable for high power-transfer applications. The type of insulation used between the phase conductor and earth also varies, with the latest material known as cross-linked polyethylene (XLPE). Cables can then be combined into different configurations to form an overall cable system, dependent on the particular application requirements. The following sections provide further details in respect of the different aspects of cable technology.

E.2 Power Cable Components

Figure E.1 below provides a cross section of a typical XLPE cable, giving a visual example of the components which may be found in an individual cable.

Figure E.1: Example cross section of a cable showing layered construction



Source: "XLPE Insulation Power Cable, EHV Cable, HV Cable", Focus Technology, 2023. Available: <https://lonheo.en.made-in-china.com/product/cKDXBiYbLjVv/China-XLPE-Insulation-Power-Cable-EHV-Cable-HV-Cable.html>

The following sections provide further details in respect of the key parts of the cable shown in Figure E.1.

E.2.1 Conductors

EHV transmission conductors are generally made from either copper or aluminium. Which one is used depends on the technical and economic conditions, with copper having better conductivity but being more expensive. These conductors are normally formed as a stranded conductor but can also be solid. For high power connections the conductors normally consist of a number of individual wires that are stranded together into conductor segments (four to six segments are typical), which are twisted together to form a circular conductor. This geometric

arrangement helps to reduce the conductor's a.c. resistance and improves the current carrying capacity of the conductor.

As a.c. conductors become larger there is a diminishing return on the additional current carrying capacity that can be obtained from increasing the conductor size. Large conductors are also difficult to manufacture due to the large number of wires to be stranded together and the conductor's weight. A large conductor will also lead to a larger and heavier cable which will be more difficult to handle during installation. It will also have a large minimum bending radius which could consequently make the cable difficult to install. For EHV transmission cable, the conductor size range is generally between 500 mm² and 2,500 mm². It is noted that although 3,000 mm² conductors are available on the market, they have a limited in-service experience and economic application.

Buried cables are additionally manufactured with water blocking tapes in the conductor to limit the extent of any water ingress into the cable should severe damage occur (for example, due to a fault or damage to the cable from an external event or activity).

The conductor within a cable carries the flow of electrical current. As the current flows through a conductor, heat is generated. The heat generated is a function of the magnitude of the current flowing and the resistance of the conductor. The heat generated results in an increase in temperature of the conductor. As the insulation is in contact with the conductor, the temperature rise must not be greater than the maximum temperature which the insulation can withstand. For modern XLPE insulated cables this insulation temperature limit is generally defined by equipment manufacturers to be 90 °C for continuous operation. The choice of conductor size and material is made with an understanding of installation conditions to economically maintain the temperature of the conductor and insulation within the operational limits.

Conductors have fundamental differences in their properties depending on whether its under a.c. or d.c. conditions. In the absence of the electromagnetic influence of alternating current, the d.c. current in a conductor can be considered to be evenly distributed throughout the cross section of the conductor (no skin or proximity effects). This results in a much more efficient use of the conductor and reduces the amount of conductive material required to transmit power compared to an a.c. system.

Further to the points above, there are no magnetic losses and it is possible to use a wider range of materials on single core cables for the tensile armour. The primary limitation with a d.c. system is the economics of power transferred relative to voltage drop, system losses and the net power at the receiving end of the system.

Buried cable circuits do not receive the benefit of air cooling unless they are installed in a tunnel or on above ground racking. To meet the continuous current rating of an overhead line conductor system, a cable circuit may need more conductors than an overhead line. In the case of high-power 400 kV systems, it is not uncommon for three cables per phase to be required to match the rating of one overhead line circuit.

For the 400 kV transmission voltage level considered in this report, one high voltage conductor is contained within one cable; this is known as a single core cable.

E.2.2 Insulation and screen

The electrical insulation forms one of the most important parts of the cable. Without the insulation the conductor would be unable to support the applied voltage and no power would be transferred.

With reference to Figure E.1, the innermost screen is the conductor screen. This screen consists of a semi-conducting compound designed to smooth the surface of the electric field

that appears on the surface of the conductor and thereby present a uniform electric field to the insulation.

Power is transferred by holding one part of a system at a high voltage and then connecting a load (for example, a motor) between it and ground. For a cable, the insulation is used to maintain the voltage on the conductor when it is buried in the ground. Without it, all the power would be transferred directly and immediately to ground and no useful transfer of power would occur. In the case of overhead lines, insulation is provided by the air surrounding it. By directly applying an insulation layer around the conductor, it is possible to achieve similar results to an overhead line but in a much reduced space.

Below is listed the primary cable insulation technologies covering HVAC and HVDC systems with differing levels of maturity. The choice of insulation technology greatly impacts the voltage level, number of circuits required and cost of the cable system.

Pressurised fluid filled systems – a.c. and d.c.

Pressurised fluid filled systems using paper insulation have been used extensively onshore and for short distances offshore. This is considered a very mature technology. Due to environmental risks, pressurised oil filled cables generally are not considered suitable for submarine installations. Onshore, this insulation medium has generally been replaced by XLPE due to the associated lower environmental risks, shorter manufacturing times, higher operating temperatures and lower operation and maintenance costs. It is not practical to use these cables in subsea applications of greater than 50 km in length and there are very few remaining manufacturing facilities.

MIND (Mass Impregnated Non-Draining) – d.c.

MIND insulation systems are built up using wrapped paper tapes, similar to pressurised fluid filled cables. However, the papers are impregnated with a compound that remains viscous at normal operating temperatures. It is considered to be mature HVDC technology with many years of satisfactory in-service experience.

MIND is not considered suitable for HVAC applications due to the small gaps that are inherent within the insulation. These can lead to breakdown and failure under high voltage a.c. frequency.

XLPE (Cross-Linked Polyethylene) – a.c. and d.c.

XLPE is a polymeric insulation system that has established itself as mature technology. Initially this was for HVAC but more recently for HVDC application. There are some significant benefits when compared to MIND, however there is currently limited service experience with HVDC cable at 400 kV. In addition, using XLPE with older (LCC) HVDC converter technology is not recommended due to the insulation not handling the rapid switching conditions particularly well.

EPR (Ethylene Propylene Rubber) – d.c.

EPR has been used extensively at lower voltage levels, particularly in the US market, due to some poor service experience with XLPE in the 1970s. EPR is available from a limited number of suppliers and its use is generally limited to voltages ≤ 150 kV.

Thermo-Plastics (such as P-Laser by Prysmian) – a.c. and d.c.

Thermo-Plastics are relatively new and offer some potential performance benefits compared to XLPE. However, in-service examples only exist at around the 30 kV range. It is also understood that an OEM has recently been awarded a contract to supply 525 kV d.c. land cable using its proprietary P-Laser technology. However, it must be noted that this technology is in an extremely immature phase of development and at present no accurate assessment presenting it as a potential alternative insulation can be made.

PPL (Polyethylene Paper Laminate) – d.c.

PPL has been widely used as a substitute for conventional paper insulating tapes in pressurised fluid filled a.c. cable systems and has also been used in some MIND cables. There is one in-service 600 kV MIND HVDC system using this technology.

Currently the dominant insulation technology for HVAC cables is cross-linked polyethylene (XLPE). This technology has succeeded the previously dominant insulation technology, oil insulated cables, due to the following primary advantages:

- XLPE has lower energy loss compared to oil filled cables.
- No risk of leakage for XLPE as it is a solid material whilst oil filled cables pose an environmental risk should they leak.
- XLPE generally poses a localised fire risk should it catch fire. In the event that oil filled cables catch fire then the fire is much more likely to spread.
- XLPE has minimal maintenance requirements. Oil filled cables require the paper tapes surrounding the conductor to be impregnated with oil. The hydraulic nature of the insulation system results in increased levels of difficulty for maintenance and jointing.

E.2.2.1 XLPE for A.C Systems

XLPE has been almost universally adopted by the HV cable manufacturing industry due to the distinct advantages it offers relative to oil filled technology. As a result, oil filled cables are not considered in this study as the technology is now generally obsolete, and in most cases, brings environmental challenges regarding possible leakage of insulating fluid.

For a.c. systems, XLPE is the dominant insulation material in today's market due to its low dielectric loss, high temperature withstand and good mechanical performance. A.c. XLPE systems have been type tested and installed with system withstand voltages of up to 500 kV a.c. onshore and 400 kV a.c. offshore. A.c. cables at 400kV and higher suffer from high capacitance issues which require a large quantity of power factor compensation. D.c. XLPE cables are typically used at that stage. Due to the harsher environment offshore, e.g. salt water intrusion, offshore cables have not reached the same level of maturity as onshore cables.

At room temperature, XLPE is a white translucent polymer capable of withstanding high voltage stress when operating at temperatures of up to 90 °C.

It is essential that XLPE insulation is kept free of water when used on extra high voltage (EHV) cables. Although the XLPE material appears watertight, at a microscopic level it is unable to prevent water vapour penetrating into the material. If water is allowed to come into contact with the insulation, the high electric stress in the cable causes tree-like degradation patterns (water trees) to grow. These trees can eventually result in failure of the insulation material. Section E.2.3 explains how the watertightness is achieved.

The outer insulation screen consists of a semi-conducting compound. Similarly to the inner screen, this is designed to electrically smooth the surface of the outer earthed sheath to present the uniform electric field to the insulation.

E.2.2.2 Insulation for D.C. Application

Where HVDC systems are concerned there are two dominant technologies. These are MIND (Mass Impregnated Non-Draining) and XLPE, which have been explained in Section E.2.2.1.

The XLPE material used for d.c. applications is an extruded cross-linked polymer similar to the a.c. application. XLPE for HVDC systems is considered to be a maturing technology, due to the fact that whilst there is a good level of experience at lower voltage levels, implementation at higher voltage levels is not yet as advanced.

The development of XLPE cables for HVDC applications has been relatively recent and some of the manufacturing processes and designs are considered as OEM protected Intellectual Property (IP). This can make it difficult for different manufacturers' cables to be jointed together, due to the unwillingness to share IP and develop suitable transition joints.

For d.c. systems, XLPE is a developing and maturing market and manufacturers have stated that extruded cable has been pre-qualified up to ± 640 kV and type tested up to ± 525 kV. Significant orders have been placed for delivery of 525 kV d.c. land cables over the next few years. At the time of writing, it is understood that there are a number of OEMs with various HVDC submarine cable solutions that have either completed type testing or are close to its conclusion. While it is understood that no 525 kV XLPE submarine cable supply contracts have been awarded to date, there are a number of projects across various countries including GB which are in planning that are likely to utilise them.

There are some significant benefits to XLPE when compared to MIND including lower manufacturing costs and lower weight. Of significant advantage, XLPE cables typically have a higher continuous withstand temperature compared to MIND cables. Therefore, for the same current rating the conductor cross-sectional area of an XLPE cable can potentially be smaller than that of the equivalent MIND insulated cable. Maximum operational conductor temperatures are not yet consistent between OEMs and offerings generally range between 70 °C to 90 °C.

There are other HVDC insulation technologies available including thermo-plastics and PPL (Polyethylene Paper Laminate) but as previously indicated, these are either in development or have very limited in-service experience. As a result, these technologies have not been considered further here.

E.2.3 Metallic barrier and screening wires.

EHV transmission cables require a protective barrier around the insulation screen to prevent moisture coming into contact with the insulation. This is often provided as a metallic barrier.

For land cable installations, the conditions typically have low water pressures and ease of access. This has allowed cables designed for this application to generally move away from incorporating lead to provide a water impervious barrier. This move has generally been required to control the health issues associated with working with lead. As a result, land cables are often provided with either a seamless or welded aluminium screen or an aluminium laminated foil.

Prior to the application of the moisture barrier, semi-conducting protective cushioning and water blocking tapes are applied. In addition, outer screening wires may also be applied along with further cushioning and water blocking semi-conducting tapes. This outer screen is usually either a Copper Wire Screen (CWS) or an Aluminium Wire Screen (AWS).

At transmission voltages cables possess a radial water barrier to prevent water ingress into the cable. This applies to submarine and land cables. Traditionally lead was used for this purpose and is still used for some applications but particularly onshore the market has moved to aluminium designs. This has been driven by various factors (handling, cost, environmental concerns). The water resistance requirement is not as stringent for land cables.

Seamed metallic barriers consist of a flat metal strip or foil applied longitudinally, with the longitudinal seam being brazed, welded or overlapped and glued. Cables with seamed barriers are generally lighter and less expensive to manufacture than seamless metallic sheathed cables.

E.2.4 Oversheath

A polymeric oversheath is applied over the metallic barrier. This provides protection against the environment and handling. The oversheath material is a thermoplastic and is slightly permeable to moisture. Typical oversheath materials include polymers that can be easily extruded into shape. High density polythene is the preferred material of choice as it offers good mechanical penetration resistance at high installation temperatures. This reduces the incidence of damage during cable laying.

However, the fire performance of polyethylene is poor and for “in air” installations a fire-retardant coating, an alternative material or a co-extruded fire-retardant compound may be used.

It is usual to apply a conductive layer on the outside of the cable as a co-extrusion to allow d.c. testing of the oversheath. This is used to confirm integrity both after manufacture, installation and at regular intervals throughout the lifetime of the cable system.

E.2.5 Bending performance

The bending performance of a cable determines how small a radius the cable can be conformed to. Dependent on the cable specifics, this may be as low as twelve times its outside diameter (12D). Such a small bending radius would normally only be used at positions where the cable can be carefully formed and controlled to constrain the cables from further bending.

For installation in a cable trench a minimum bending radius of 20D may be employed for final positioning. Usually, cable installers prefer to install the cable with a minimum bending radius of 30D or above, as this eases the pulling forces required to install the cable. During installation it is preferable to install the cable on as large a radius as possible to improve cable handling and reduce the risk of cable damage.

E.2.6 Cable system accessories

Apart from the main cable there are additional cable accessories which are required to construct a cable system with the three main ones being as follows:

- Joints.
- Terminations.
- Earthing and bonding equipment.

In general, the design of an accessory will have been the subject of long-term reliability testing. Components will also have passed factory manufacturing and acceptance tests. The assembly of accessories occurs on site without the controlled environment of a factory. Reliable performance of EHV accessories therefore requires skilled jointers, specialist tooling and a suitably prepared and controlled jointing environment.

In order that the cable system as a whole carries a manufacturer’s warranty (often between one to ten years), almost invariably a manufacturer will insist that its trained personnel assemble each accessory and possibly supervise the cable installation.

E.2.6.1 Joints

Cable joints connect separate cables lengths into a single unit. Joints (and terminations) are often referred to as, electrically speaking, the weakest points of a cable system. This is primarily due to the high electrical stress control requirements of accessory designs. However, the need for accessory component assembly on site where it is difficult to replicate the clean and controlled conditions that can be found in a factory environment are also a significant contributor to this reputation.

The high reliability required of a joint or termination will depend upon a fully tested manufacturing design, a specialised manufacturing process, a fully considered installation design and a high standard of accessory assembly. To increase the reliability of the system, it can be advantageous to increase the cable section lengths and reduce the number of joints as part of the overall design solution.

Underground cables have significantly more joints per km than subsea cable. At present, for UGC a joint is required approximately every km, with this limit primarily being imposed by weight and size restrictions of the drum required to deliver the cable via land routes to site. For offshore cable meanwhile, the cable laying vessel can transport and lay much larger lengths.

Cable joints connect together separate drum lengths of cable to make a continuous electrical connection. Each cable manufacturer will offer its own design of joint. The main components of a joint are generally present in all joints but with design details of each component differing between manufacturers' solutions.

The time required to complete a joint bay containing three joints will depend on a number of factors. Once a jointing team is available to assemble a joint bay the process should take in the order of three to four weeks. Figure E.7 shows an example of a joint bay, with a cable being pulled into position.

An underground cable circuit at transmission voltage will comprise of three separate single core cables as indicated in Figure F.1 and a joint will be required for each individual cable. For the cases considered in this study, the following will be required:

- Low Rating: double circuit with one cable per phase. Total of six joints at each jointing location.
- Medium Rating: double circuit with two cables per phase. Total of 12 joints at each jointing location.
- High Rating: double circuit with three cables per phase. Total of 18 joints at each jointing location.

E.2.6.2 Termination

Cable terminations produce a secure insulated connection that joins the cable system to other electrical units e.g. switchgear. This also allows cables to also connect to transition towers to raise the conduction path to an overhead line. This allows power transmission to alternate between the two methods before terminating to equipment that receives and utilises power. Where this transition takes place it will be necessary to construct a compound housing the steelwork upon which the terminations will be mounted, and allowing sufficient clearance for connection of the conductors from the OHL.

Air, SF₆ gas and oil-immersed terminations are all available for XLPE cables. However, for this costing study the gas-insulated termination has been considered, as this is understood to now be the most common type of termination in use³⁴.

The method of installation of the cable terminations depends on the supplier as each supplier uses a different method.

Following installation of the cable, the termination of three cables will take around four weeks to complete. As per the joints, each individual cable will require a termination and thus for a low rating cable six terminations will be required at each location, for a medium rating 12, and for a high rating 18.

³⁴ Source: Table 11 of CIGRE TB 815 which gives figures of failure rates between 2005-2015.

Figure E.2: Example of cable sealing end compound



Source: “400 kV Underground Cable Construction”, National Grid, 2011. Available: <https://www.cablejoints.co.uk/upload/400kV-Underground-Cable-Construction---Installation-Trenching-and-Jointing---National-Grid-UK.pdf>

E.2.6.3 Earthing and bonding equipment

When an electric current passes through a conductor, a magnetic field is generated that couples with the metallic screen on the outer layer of the insulation. This field induces a voltage into the metallic screen. If the screen is connected (bonded) to earth at both ends of the cable, then a current will flow in the screen. This generates heat and reduces the efficiency of the system. The magnitude of the current in the screen is proportional to the current in the conductor and dependent on the resistance of the metallic screen.

The application of special bonding can reduce cable sheath heat generation considerably by preventing the sheath current from flowing. This is used to improve the overall amount of power that can be transmitted through a cable system without exceeding thermal limits. However, the method of bonding the screen results in a voltage rise along the cable metallic screen/sheath and any screening wires. The magnitude of this voltage is affected by the:

- Magnitude of the current flowing in each of the circuit phase conductors.
- Spacing between the cable sheath/screen and each conductor.
- Geometric arrangement of the cables within the cable trench (or trenches).
- Length of cable between specially bonded joints or terminations.

Special bonding arrangements require the use of earth link pillars (above ground) or link boxes (underground) to be positioned at joint bays and terminations.

Link pillars or link boxes will be required at every specially bonded joint bay or termination position, illustrated in Figure E.3 One pillar or box is required for each group of three power cables.

Where the links in a pillar or box cross-connect cable sheaths, a sheath voltage limiter is installed. This device prevents over-voltages appearing on the cable sheath (or metallic barrier) during abnormal system events.

The bonding cables and equipment within these pillars are capable of delivering both electric shocks and burns. The pillars must be capable of withstanding an internal flashover which may occur in the event of an abnormal system event. Each pillar will have a separate earth mat for the bonding system and the link pillar carcass. This mat consists of bare copper tape and earth rods installed below ground.

Care must be taken to position or protect the pillars from harm. In rural environments this could mean protecting the pillar from farm equipment and large animals by using bollards or stock-

proof fencing. In urban locations protection may be afforded by placing the pillar away from traffic.

Figure E.3: Example of above ground link pillar



Source: “Cast Iron Feeder Pillars – Lucy Zodion”, Thorne and Derrick International, 2023. Available: <https://www.powerandcables.com/product/feeder-pillars/cast-iron-feeder-pillars-lucy-zodion/>

E.3 Cable Maintenance and End of Life

E.3.1 Repair

In some instances it may be necessary to undertake a repair to a cable following a fault. Faults can be caused by a variety of means, including failure of components within the cable system itself (for example, the joint), or damage by a third party (for example, as a result of an excavation in the highway). It should be noted that during the operational lifetime of the cable system, most cable damage is the result of third-party activity. Under such circumstances it is necessary to obtain access to the cable in order to carry out investigation and repair works, and hence the design of cable routes generally needs to take into consideration suitable access and egress for the lifetime of the asset. In general the cable route also needs to be kept free of significant vegetation. Weather may restrict access to the cable in very wet spells or prolonged periods of snow.

The fault will first need to be located and a decision made on how it will be addressed. Repairs to cables require excavation of the cable and the provision of clean and dry conditions for jointing. The absence of either of these may affect cable repair times and repair reliability. It is usually necessary to cut out the faulted piece of cable and install a new length, along with two joints. This process can involve significant civil works, and can be time consuming. It is also reliant on the availability of the necessary joints for the type of cable which has failed, and for this reason it is common for TOs to maintain stocks of strategic spares including lengths of cable and joints.

E.3.2 Maintenance and Inspection

Cables need to be maintained and inspected over their lifetime to ensure and verify that the cable system is in good condition and will be able to be operated safely. A minimum cable

system design life of 40 years is typically provided by manufacturers although they may stay in service for longer than this, with warranty periods normally between one and ten years.

Maintenance of power cable systems falls into three categories:

- Route patrols and inspections.
- Planned service maintenance.
- Emergency fault repairs.

Regular patrolling of the cable route where personnel look for third parties working close to the cable route and identify land use changes is done as maintenance. This can reduce the likelihood of damage to the cable system as a result of third-party activity. With cable systems that are easily inspectable such as within cable tunnels, route patrols can be used to visually verify the condition of the cable system.

Planned service maintenance would require the opening of link kiosks or pits to inspect and check the condition of the kiosk and the equipment within. Cable oversheath and SVL (Sheath Voltage Limiter) tests (if required) would also be performed from these locations through application of a d.c. voltage. This test helps to verify the condition of the cable oversheath and identify whether any damage may be present on the cable.

Some cable manufacturers are offering “maintenance-free” systems. However, this statement refers only to planned service maintenance. It is advisable to check the condition of any equipment which is susceptible to third-party interference.

E.3.3 Decommissioning

At the end of the cable's workable life it would need to be decommissioned. When extra high voltage (EHV) XLPE cables become due for decommissioning the following options are available:

- Reduce the operating voltage level to extend the cable system's service life,
- Remove the cable system entirely and reinstate,
- Partially remove the cable system, or
- Remove the cable system entirely and install a new system in its place.

Depending on the reason for the decommissioning of a cable circuit, the cable system may be capable of operating at a lower voltage level, e.g. 132 kV or 11 kV. Not every circuit would necessarily be in the correct position to be useful when operating at a lower voltage and there would be a number of practical difficulties.

Whilst there can be a considerable quantity of copper, aluminium or lead in a cable it is not foreseen that the price of scrap metal will increase sufficiently for it to cover the full cost of the cable decommissioning. The materials in a large conductor EHV cable system are not currently biodegradable. There is, however, research being undertaken into the use of recycled materials to make new insulation. In addition to this there is also ongoing development of processes that will biodegrade insulation materials at end of life and the development of new insulation materials that will be more sustainable and environmentally friendly throughout the lifetime of the cable system. The availability of sustainably sourced insulation materials will also impact the carbon emissions of the cable system (and thus overall project).

To completely remove direct buried cables from the ground a process similar to installation must be done. It is not foreseen that the cement bound sand (CBS) which surrounds the cable would be removed from the ground though all else would.

If partial removal of the cable system is required then this could be limited to the items above ground that adversely affect visual amenity, such as pillars and associated fencing or bollards. If the cables are installed in air-filled ducts, the cable may be withdrawn from the ducts at duct opening positions without the need to excavate the entire length of trench.

E.4 Cable Civil Works & Installation

The cable system civil works cover the modifications and additions to the environment that allow the cable system to be installed and operated. This covers works where material is removed such as trench excavation as well as where items are added such as laying a duct or installing cable tunnel brackets. The different methods of installation impact the cable operating environment which dictates how readily heat from cable losses can be evacuated away from the cable. This impacts the amount of power that can be transmitted through the cable system.

The method, location and routing of a cable circuit are each determined during a site survey which considers the practicalities of employing a given cable system. Examples include installation in:

1. Air on cable supports.
2. Surface trough.
3. The ground directly buried with or without thermally stabilised or replacement backfill.
4. Ducts, either filled or unfilled.
5. A tunnel with or without forced cooling.

The location of the cable route will be limited by issues including:

1. The total length of cable required.
2. The availability and cost of land.
3. Access limitations.
4. Ground conditions and ground stability for excavation and cable installation.
5. Obstructions, e.g. unstable ground, difficult terrain, tree roots and immovable structures.
6. Disturbance to the environment and stakeholders.
7. Maintenance access.

Access to the entire route must be agreed before works can commence. Ideally this will be performed prior to the commencement of construction works or a risk assessment will have been taken on each area of doubt. The following subsections detail the main tasks to be undertaken.

E.4.1 Project Construction Schedule

The time required to construct a cable system is highly dependent on the power rating requirements, cable route and associated constraints and obstacles and the method of installation. In general, it can be anticipated that in a rural environment, a direct burial system will be quicker to install than a ducted system, although these timeframes will be quite similar. In an urban environment where access is more difficult and the impact of opening long sections of trench prior to installation of the cable can be very disruptive, it is often beneficial to use a ducted system so that the civil works can be undertaken in defined sections and decoupled from the cable installation works. Should the challenges associated with a trenched system prove too great, then a trenchless system (e.g. deep tunnel) is often considered. The timeframes associated with the construction of a tunnel system are relatively long due to the heavy civil works.

E.4.2 Site accommodation and storage

During construction there would need to be site facilities for worker welfare, as well as storage sites for materials prior to their utilisation. This storage location would vary from site to site and depend on the availability of local land for hire, availability of utilities, security considerations, environmental suitability and the proximity of the site to main roads.

Dependent upon the location, generators, fresh and wastewater storage tanks, waste material, floodlighting and flammable gas storage will be required to support the operational and welfare facilities. It should be noted that a proportion of the site power and equipment is able to be provided by on site renewables (e.g. solar, hydrogen, EVs etc) and green storage in addition to conventional internal combustion generator sets. These newer methods reduce the demand for fossil fuels on site in line with climate change net zero targets.

Access to the site may require traffic management to be installed to allow safe entry and egress.

E.4.3 Enabling works and special constructions

Enabling works are construction works that should be performed before beginning the main cable installation works e.g. to enable access to the site, demolish structures, remediate polluted land etc. This includes the installation of temporary access roads or the improvement of existing farm tracks.

Prior to commencement it would be necessary for the contractor to identify any route obstructions and confirm that there is an economic solution enabling cable installation. Details of recorded services would be obtained from utilities, and discussions held with landowners regarding any services on their property (including unrecorded services installed by the landowner).

Once cable installation becomes viable, it may proceed. During the cable civil works, there may be particular route sections that require special constructions. These are over and above what's typically required to install the cable e.g. long drillings, cable bridges, tunnels and submarine crossings. These works may be required due to difficult thermal or spatial restrictions encountered during the route such as a road or river crossing.

For road crossings a decision must be made on the method. The installation of polythene or uPVC ducts is commonplace and may require traffic management. For busy carriageways or railway crossings the use of other methods such as directional drilling may be necessary to prevent unacceptable traffic disruption.

Methods available for crossing water (e.g. canals, rivers, ponds and lakes) include:

- Bridging.
- Drilling or tunnelling beneath the bed.
- Dredging a trench in the bed.
- Laying the cables direct on the bed or in ducts.
- It is normally preferred to make use of nearby existing structures for the crossing where possible.

E.4.4 Cable and circuit spacing

The power that can be transmitted through a cable is limited by the maximum temperature of the cable insulation. As the cables dissipate transmission losses as heat during operation, they heat themselves, the environment and other cables. This mutual heating increases the environmental temperature, reducing the amount of power the cable systems may transmit

before the temperature limit is breached. This results in two or more cables needing to be separated from each other when underground to limit thermal interaction and mutual heating.

Prior to undertaking a cable route in an urban area it is necessary to confirm that there is space to accommodate both the cables and the joint bays in the roads. The late discovery, for example, of a large sewer obstructing a cable route can increase costs with both the requirement for an additional special construction and the delays in procuring its design, if one can be developed.

When high-power transmission circuits are installed under public roads, the road may be used as the means of site access. However, the surface of the road must be broken and removed and reinstated after installation. Traffic management, space restriction and the need to reinstate the road surface all increase the cost of installation in urban areas.

When subterranean services become sufficiently dense, tunnelling and the future asset the tunnel represents for additional services becomes attractive. This normally involves the construction of a deep tunnel far beneath the ground surface using tunnel boring equipment which greatly reduces the above ground impacts.

Prior to any excavation, the area within the swathe must be worked during the right time of year. Generally, the best time for working on the land is between April and October when rain and snowfall are less prominent. There are also likely to be issues regarding disturbance of birds or other fauna or flora that may need to be addressed.

During the construction phase, the space requirements for the groups of conductors, plus the haul road and space for the temporary storage of spoil from digging the trenches, amounts to the construction swathe width. The swathe width depends on the number of cable groups, space required to limit thermal interaction and the backfill thermal properties. These options have both technical and cost implications.

E.4.5 Rural swathe preparation

The construction swathe in a rural area is vulnerable to being inundated with water depending on site geography. If required, following a land drainage study, appropriate mitigating actions should be taken to redirect water away from the site to minimise harm & damage.

Within the swathe the topsoil would need to be stripped and stored to one side. To prepare the swathe for construction works, a temporary haul road would be installed along the route between access points onto local roads. These access points would need to be agreed with the local authorities and interested parties. In principle the haul road would carry as much as possible of the construction traffic. However, some vehicle journeys on local roads would be inevitable to reach the site access points and make use of such facilities as road bridges where rivers or railways cut across the route. Figure E.4 gives an example of a cross section for an underground cable route. As can be seen, this is for a project with three cables per phase, and incorporates a central haul road, and clearance on either side for storage of material.

Figure E.4: Cable construction corridor with three cables per phase

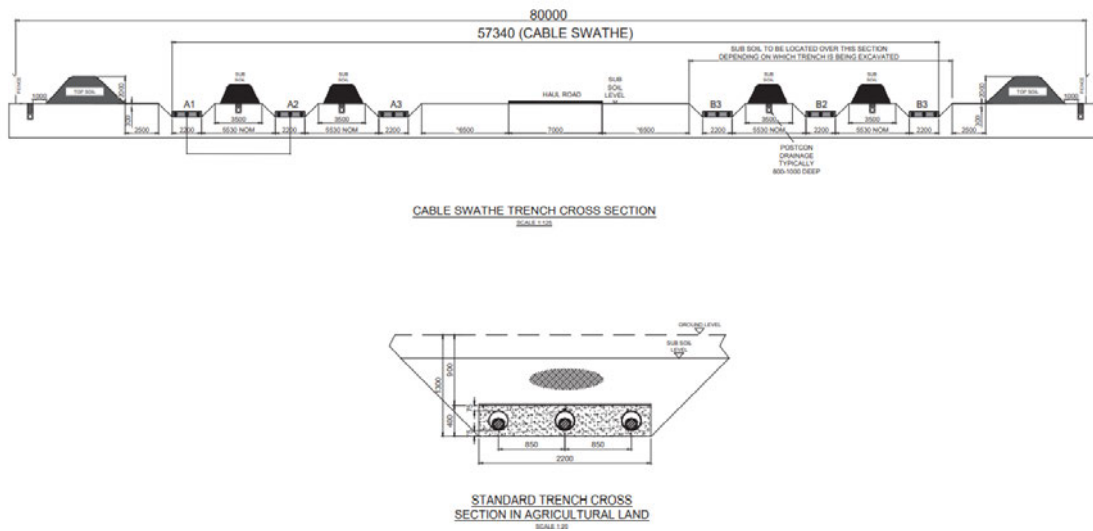

Source: "Bramford to Twinstead Reinforcement", National Grid, Jan. 2022. Available: <https://www.nationalgrid.com/electricity-transmission/document/140351/download>

E.4.6 Cable installation for Direct Buried Installation

E.4.6.1 Excavation & transportation

Along the cable route the construction of trenches would require excavation to accommodate the power cables. Additional excavations would be required at the joint bay positions to accommodate the power cable joints. If the ground is waterlogged, dewatering may also be necessary.

Once the bottom of the cable trench has been cleared of sharp and large objects, a cable bedding is laid to allow installation of cables and any fibre optics.

During trench preparation, the power cable drum would arrive at one of the joint bay positions. The area around the joint bay would have been prepared to accept the drums onto a hard standing. The drums are delivered to site by a suitable vehicle. The required vehicle size varies depending on cable drum size, but loads are generally large and heavy. Figure E.5 shows a typical example of a cable drum being delivered.

Figure E.5: Example of a cable drum being transported



Source: "SEB CD980S Extendable Cable Drum Trailer", Thorne & Derrick International, 2023. Available: <https://www.powerandcables.com/seb-cd980s-extendable-cable-drum-trailer/>

Transporting the drum through country villages and along country lanes may present problems and road safety and access measures may be necessary e.g. removal of street furniture. Depending on the road conditions a detailed transportation and access survey may also need to be undertaken.

E.4.6.2 Installation

Once delivered to site the cable would be pulled and unwound from the drum and then guided and laid within the trench. Cement bound sand (CBS), delivered by mixer would then be tamped into position around and over the cables. Cover tiles containing a warning are then installed above the cables, these are fabricated from either reinforced concrete or reclaimed polymeric materials. Warning tape would then be installed above the cover tiles.

Figure E.6: Example of direct buried cable installation



Source: "Cable Grips | Supporting Inter-Array, Export, Umbilical & Subsea Cable Installations", Thorne & Derrick International, Jul. 2021.
Available: <https://www.powerandcables.com/cable-grips/>

E.4.6.3 Backfilling

Following the installation of the cables the excavated material which was not removed from site would be used to infill the trenches and would be compacted. The remainder of the excavated material would be stored on site, separate from the topsoil and used to complete the backfill of the inner trenches and joint bays following cable system installation. Once backfill is completed, the surplus material would need to be removed from site as waste/landfill or repurposed another way.

The duration of the excavation, cable installation and backfilling works for the cable section will depend on the nature of the ground, e.g. rock content, dewatering content etc.

For a large project in the order of 75 km it would be necessary to split the project into areas and to have a number of construction teams at work simultaneously.

E.4.7 Cable Installation for Ducted Installation

E.4.7.1 Excavation & transportation

Ducted systems are often preferred as they enable the construction and route alignment works to be decoupled from the cable installation works. Excavation for ducted cable installation occurs in a similar manner as the direct buried case. This would occur in a continuous operation with excavation at the front, followed by the installation of the ducts and reinstatement of the ground following on as duct installation is completed. This offers the advantage that large amounts of work can be undertaken quickly without significant quantities of open excavations. The ducted route can be installed, backfilled and left for a period of time prior to cable installation.

E.4.7.2 Installation

The design of a ducted cable route would include the provision of joint bays and pulling pits at suitable locations. Once the time comes to install a section of cable, two or more of these are excavated and the cable drum is situated at one of them. A winch is situated at the other, and the winch cable is pulled through the ducting system using a drawcord. It is usual for ducts to be cleaned prior to installation of the cable, to ensure there is no debris present. A special fitting is attached to one end of the cable, and the winch cable is connected to this fitting.

Cable installation into a ducted system relies on low friction between the cable duct and the cable. This is achieved by installing clean ducts with very gradual bends and using biodegradable water-based lubricants. Sometimes rollers can be used, particularly if it is necessary to navigate bends. Cable data sheets include maximum pulling tensions and, during the installation process, the force exerted by the winch must be less than the specified maximum tension. Winches will usually include monitoring equipment to demonstrate the pulling tensions which were used, with this information being recorded in the quality file. Figure E.7 shows an example of a cable drum, with a cable being pulled into position at a joint bay location.

E.4.7.3 Backfilling

Backfilling would occur in a similar manner as the direct buried case.

Figure E.7: Cables being pulled into ducts at joint bay location



Source: "Seagreen Onshore Project Get Cable Pulling Underway Across 19 km Route Through Angus, Scotland", SSE Renewables, Aug. 2021. Available: [https://www.sserenewables.com/news-and-views/2021/08/seagreen-onshore-project-get-cable-pulling-underway-across-19 km -route-through-angus-scotland/](https://www.sserenewables.com/news-and-views/2021/08/seagreen-onshore-project-get-cable-pulling-underway-across-19-km-route-through-angus-scotland/)

E.4.8 Cable Ploughing

Another method outside of traditional cable burial installation practices is that of cable ploughing. A cable plough allows the cable to be laid underground without having to undertake extensive trench works. This is achieved via a plough laying-chute mechanism. The plough, positioned at the cable laying depth, carves through the soil, creating the cavity channel while the laying chute simultaneously lays the cable. The plough then allows the native soil to fall back into position to cover the cable, allowing continuous cable laying through the route.

Whilst there are significant advantages to cable ploughs in terms of swift programme, relatively minimal disruption to the environment, and fewer preparatory works, there are limitations to this installation method. At present, ploughing has only been well-established practice for lower voltage cables, up to 220 kV, and we are not aware that a suitable machine has been demonstrated for use at 400 kV. In addition, while the plough can plot a relatively flexible route, with bending radius of 4 m, allowing it to navigate through obstacles such as trees and rocks, it is not suitable for particularly hard soil or rock. For circuits where the rating requires backfill with particular thermal characteristics, as is often the case at transmission level, and which applies to the ratings considered in this report, it is unlikely that a cable plough would be suitable. Cable tiles will also be required which it may not be possible to install with a plough.

E.4.9 Swathe Reinstatement

Following installation of all cable and joints in a section, the swathe would be cleared. This will include the removal of any remaining security fencing, uplifting and removal of the haul road and temporary hard standing areas, and reinstatement of surfaces and topsoils.

Where necessary, this reinstatement may include replanting of hedges, replacement of fences, removal of temporary land drains and settlement ponds, reinstatement of permanent land drains and the like.

If trees are removed, these would only be replaced if their roots did not interfere with the power cable installation. The allowable distance of any tree from a cable would depend on the type of tree and its expected future growth.

E.4.10 Horizontal Directional Drilling installation

Not all cable installation methods require a trench to be dug into the earth. Some methods only require a cavity along the route to be excavated. An example of this is horizontal directional drilling (HDD) where a drill is used to excavate space underground along the cable route in a guided manner. This reduces the amount of material that needs to be excavated as well as some limited ability to move the cable around obstacles.

Horizontal directional drilling allows ducts to be routed under obstacles by first drilling a directionally controlled pilot hole (normally around 50-75 mm in diameter) from a surface position or a starter pit located on the near side of the obstruction through to a surface or reception pit located at the far side. The pilot hole is subsequently enlarged to allow follow on installation of the product pipe. The bore is supported at all times with re-circulated bentonite slurry. This method (HDD) is particularly useful for crossings of a few hundred meters but could be slightly longer. It is commonly used for navigating waterways, rail crossings, major roads and other similar obstructions. In submarine cable systems it can also be used at the transition point between landfall and water.

HDD is generally considered to be a specialist field with the majority of completed bores having a typical diameter in the range of 300 mm. Larger ducts up to and in the order of 1,000 mm in diameter can be achieved but this requires specialist experience and equipment. Figure E.8 gives an example of a HDD rig.

Other methods of construction such as tunnel boring exist and are discussed in more detail in Appendix F.

Figure E.8: HDD rig



Source: "HDD Technique", Drilling Contractors Association, 2023. Available: <https://dca-europe.org/hdd-technique?lang=en>

E.5 Application of the Technology

E.5.1 Installation comparison

Electrical power needs to be transmitted through a variety of different installation environments and scenarios which cover:

- Densely built-up areas.
- Immovable obstacles/obstructions.
- Cable tunnels.
- Wide clearances from the ground to the conductor.
- Unstable ground.
- Mountainous terrain.

In the case of densely built-up areas where the subterranean service density (number of other cables, pipes, sewers and ducts etc. along a route) is not too high the power cables may be physically accommodated within a narrow trench. This confinement of power cables to a narrow trench enables cables to be installed in locations where wide trenches which might accommodate gas-insulated lines (GIL) are not available.

The limit on the trench size and of the proximity of one group of three a.c. cables to the next is largely determined by the thermal constraints of heat dissipation. The majority of cables are installed in urban and peri-urban environments.

When there are obstructions or obstacles, underground cables may be used to pass beneath them. The technology of horizontal directional drilling (HDD) is capable of installing a polythene pipe beneath an obstruction through which transmission cables may be installed. These

obstructions may exist within cities, and include arterial roads, railways and rivers. The maximum length of the installed cable pipe is dependent upon the ground conditions for drilling and the capability of the drilling machines.

However, if ground conditions do not suit drilling and the required installation length is not too long (in the region of 100 m) then other methods, such as pipe jacking (where a metal pipe is thrust/jacked from the rear) may be considered.

In urban environments where service density is high, cables may also be installed within tunnels. This helps with installing, protecting and maintaining cables beneath busy urban environments e.g. London. This helps avoid unacceptable disruption of transit and other services. Once a tunnel is installed the expected life of the main structure (100 years or more) may be expected to exceed the lifespan of the cables (40 years). Tunnels are discussed further in Appendix F.

Areas that have wide aerial clearances would be biased towards overhead lines rather than underground cables. The clearance would allow the air to electrically insulate the conductors rather than require cable insulation. The greater amount of ground works required by the use of cables would also dissuade their use.

Underground power cables are not so useful for installation in unstable ground conditions. Cables installed in the ground are mechanically restrained by the surrounding backfill within which they are held secure. However, if the surrounding backfill moves or slips, the cable can be placed into excessive tension or compression. In extreme cases shear forces across the cable can occur, deforming the cable. Poor installation ground includes ground liable to land slip, such as shallow soil on a rock incline where heavy rains can cause the soil-to-rock interface to become unstable. The installation of cables across wet unstable ground such as peat bog can be problematic due to the problems of settlement and the non-uniform forces acting on the cable and the joints. Under such conditions overhead line tower foundations and piling offer a more secure solution.

The installation of cables in mountainous terrain is also problematic. During a study into cable installation in Perth and Kinross in Scotland during the Beaully-Denny transmission line public inquiry, a cable route passing between Tummel Bridge to Appin of Dull was considered. The mountainous terrain was so adverse to direct buried cable installation that the only feasible solution appeared to be the installation of a cable tunnel. The V-shaped valley route is currently traversed by a multiplicity of overhead line towers.

Mountainous terrain can be poorly serviced by trunk roads with bridges capable of providing access for the cable transport to deliver the large and heavy cable drum carrying vehicles (up to 59t GVW). Even if it is possible to deliver cable to the site, it may not be possible to excavate side-slope gradients without terracing, which may be visually unacceptable. This report has not considered the cost of large-scale rock cutting or blasting to excavate trenches in rock. Any requirement to deliver reactive compensation equipment may also be problematic, as this abnormal load may require a 120t road load-carrying capability. Bridge modifications or strengthening may also be required, which may adversely alter the nature of a bridge. For example, there may be particular concerns where modifications are required to infrastructure that is considered to be part of our cultural heritage or where the modifications may detract from the original aesthetics.

In mountainous terrain overhead lines are the preferred technology. With an overhead line it is possible to deliver tower materials in small sections by helicopter to some of the most inaccessible locations, and the conductors, suspended between the towers, are pulled into position and can relatively easily span rocky outcrops, vertical rock faces, deep ravines, small lakes, rivers and bogs with much less time, trouble and effort than a direct buried underground

cable, which would have to be laid, buried, bridged and secured, and at times the accommodation for cables blasted into the terrain.

E.5.2 System comparison

The system operator may also opine on whether to use cables or overhead line systems for reasons connected to network stability that might not be visibly apparent.

Electrical systems within the UK operate at an a.c. frequency 50 Hz. This means that current is continuously forwarded and reversed 50 times a second to deliver power. Depending on the characteristics of the network, there is a risk that a resonance effect may occur, where power builds up to dangerously high levels on a particular segment of the system.

This is similar to pushing someone on a swing where the swing acts as a pendulum that stores energy, and every push adds a little more energy to the system when done at the right timing. Depending on the network, the system operator might have a preference on the type of conductor used to avoid the system resonance frequency matching the 50 Hz frequency of the electrical power.

E.5.3 Environmental, Sustainability & Local Impact Comparison

Underground cables may also be installed for reasons of environmental benefit and safety. During the construction phase, the installation of buried cables takes longer than an overhead line and the groundworks are more extensive with vegetation destruction across the cable swathe. However, in the long term, the lower visual impact of cables compared to overhead line may outweigh other adverse environmental impacts (for example, the impact to buried archaeological remains and the local hydrology). Use of tunnelling can lessen the amount of surface excavation which in turn reduces the associated environmental damage.

Apart from the environmental impact to site, cable systems also have a bigger material footprint per metre than overhead lines. This is primarily in the form of plastics that form the insulation and oversheath of the cable. During disposal of the conductor, these materials would form plastic waste which would potentially go to landfill. This would also represent a carbon cost.

Overhead line conductors are primarily composed of metal that can be recycled (aluminium and steel). This reduces the quantity sent to landfill and decreases the climate impact.

Underground cables may also be installed to allow other privately financed developments. The finished value of a development may be increased due to an improvement in the visual amenity from installing a cable system or the development may not be possible without the removal of an overhead transmission system.

E.5.4 Cost Comparison

The cost of a cable can be broken down to:

- Material.
- Installation.
- Operation & Maintenance.
- Decommissioning.
- The cable is composed of a conductor surrounded by insulation, screening and an outer sheath.
- This extra material relative to an overhead line (composed of mainly a conductor and possibly some reinforcement) means the material per km is higher for a cable. Cables are

also installed within thermally constrained conditions which require a higher conductor cross-sectional area to transmit a given value of power relative to overhead lines.

- The installation of cables requires excavation or tunnelling. The difficulty in this depends to some extent on soil conditions and on the volume of excavations required. This is further complicated by needing to cross existing services. It can be generally assumed that the installation cost of cables is higher than overhead lines in most cases.
- HDD technologies can reduce the excavation volume required compared to trench installation of cables. However due to its technical nature, it is more costly than standard cable installation and would typically be used as a secondary option. HDD length is also limited by the transportable cable length which is often less than 1,000 m.
- The operational costs of both cables and overhead lines are quite low as they are both relatively static items of equipment. The cost of maintenance covers planned maintenance such as inspections. This is generally easier for cables within tunnels than direct buried cables or systems installed in ducts that cannot be easily monitored. Overhead lines are easily monitored as they are in the open though accessing them in mountainous terrain might be a source of some difficulty.
- Operational costs also cover unplanned maintenance that is required during faults. This is generally more difficult for cables as faults are not so easily detected whereas overhead line faults are able to be detected readily due to being exposed.
- Decommissioning typically involves similar steps as installation and so cables have a higher decommission cost than overhead lines for similar reasons. Cables installed within duct or tunnel systems can be removed whilst leaving the civil infrastructure intact which reduces decommissioning costs.
- The greater quantity of non-recyclable plastics within cables makes the disposal costs higher relative to overhead line systems.
- Section 4 gives quantitative details on cable cost information.

E.5.5 Schedule Comparison

Modern cables and overhead line conductors are both typically constructed using an extrusion process where materials are continuously formed into the required shape. This process is efficient and whilst cables require more material, the time for construction isn't expected to differ significantly.

More relevant is the availability of factory slots which varies depending on market trends.

For the civil works construction and conductor installation, the schedule time varies for both OHL & UGC depending on the environmental conditions for each. Comparatively overhead lines are quicker to install as pylons can be constructed quickly and the civil works for their foundations are minimal. Conductor installation is similarly brief.

Cable installation by contrast requires large amounts of material to be excavated and either disposed or backfilled which results in long project durations. The exact duration depends both on length, environmental conditions and the types of works required e.g., installation of ducts adds to the schedule length.

For installations buried within a trench, the material to be removed is the entire trench width and depth which requires a large amount of excavation. Excavation can be expedited with multiple teams excavating different trench sections in parallel. This material then has to be utilised or disposed when backfilling the trench.

Cable installation via tunnels by contrast primarily only require excavation of the cavity required for the cable installation. However, they generally have a longer programme (and higher cost)

due to the methods of excavation. Tunnelling is typically utilised due to project constraints preventing the use of trench excavation.

For more information please refer to Section F which goes into detail on tunnelling.

E.6 Anticipated future developments

The main development in the cable field is likely to be implementation of HVDC cables at higher voltage levels. Other developments include pressurised air cables and super conducting cables. Appendix H gives details on these technologies. Future developments improve upon standard technology either by expanding the capability (greater power throughput) or by reducing some form of impact (reduced size, cost or environmental impact).

E.7 Submarine Applications

E.7.1 HVAC Submarine Cables

The presence of the capacitive charging current is one of the key limitations of long a.c. electrical systems that can be managed, within limits, through the careful design and placement of reactive compensation systems.

Submarine cables for a.c. systems are normally provided as a three-core composite construction that allows all three cables to be installed simultaneously which reduces installation costs and durations. However, the three-core construction can make the cable very heavy and difficult to handle, particularly at higher voltage levels and where large copper conductors are used. Figure E.9 shows a typical HVAC submarine cable.

Figure E.9: Typical HVAC submarine cable cross section

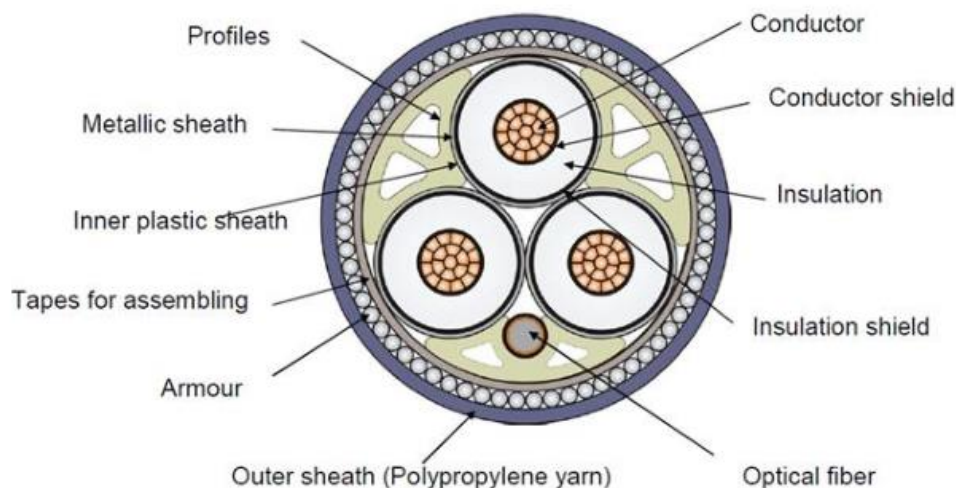

Source: "Effect of Sheath Plastic Deformation on Electric Field in Three Core Submarine Cables", Semantic Scholar, Oct. 2018. Available: https://www.semanticscholar.org/paper/Effect-of-Sheath-Plastic-Deformation-on-Electric-in-Hamdan-Pilgrim/d8a6900a7349ff_d5483fd_e9c678df_cf60b7349ab/figure/0

E.7.2 HVDC Submarine Cables

HVDC submarine cables have a very similar construction to the HVAC type. However, as the electric field is time invariant (static) they have no continuous steady-state requirements for capacitive charging current. The capacitive charging occurs only when the system is energised. Post-energisation, the full transmission capacity of the cable is available for active power

transmission. Additionally, as discussed in 0, submarine cable conductors also exhibit differences depending on whether the current is a.c. or d.c.

Submarine cables for d.c. systems are commonly provided as a single core construction. This is in part due to the different configurations possible with d.c. systems that make it simpler for OEMs to design single core cables for manufacture rather than designing a range of composite cables (some with metallic return and some without). The most common approach at present is to use two separate single core cables which are bundled together on the vessel prior to laying. This means that in the event of failure of one cable, the HVDC link would be out of service. Alternatively, cables can be laid individually and spaced apart, although this can lead to deviations of magnetic compasses and is not permitted by some authorities. Laying the cables individually could reduce the extent of lost power transfer capacity following a cable fault, but a metallic return would be required to maintain the remaining pole in service and provide a return path for the circuit current. As the distances of such HVDC links are generally large, inclusion of a separate metallic return conductor would significantly increase the cost, both in terms of material supply and installation. However, we are aware that developments are ongoing in this area, in particular by the TSO TenneT which is working with manufacturers to develop a HVDC cable system with separate metallic return. Figure E.10 shows a typical HVDC submarine cable.

Figure E.10: Typical HVDC submarine cable cross section

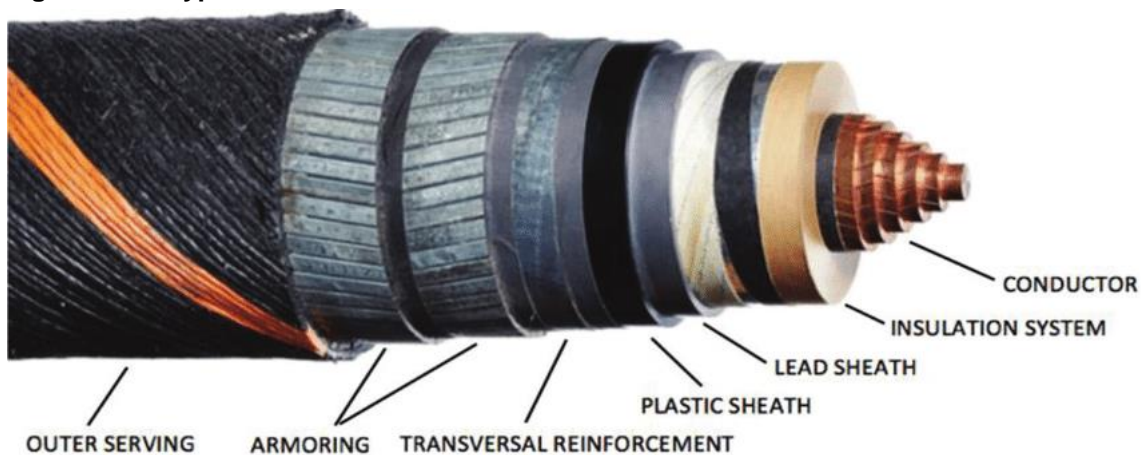

Source: L Våben, O Gudmestad, "Design and installation of high voltage cables at sea", International Journal of Energy Production and Management, vol 3, no. 3 Oct. 2018. Available: <https://doi.org/10.2495/EQ-V3-N3-201-213>

E.8 Submarine Power Cable Components

The key components in submarine cables are similar to those for underground cables. Discussion in the following sections is only provided in reference to layers which are impacted by submarine installation. Reference can be made to Appendix E.2 for details related to common aspects.

E.8.1 Conductor

In addition to the conductor types discussed in Appendix 0, for HVDC systems keystone conductors may also be used. These consist of a circular conductor cut into a number of solid keystone shaped sections. These offer good natural water blocking at the expense of flexibility. The small gaps between the keystone sections will be filled with a water blocking material.

E.8.2 Insulation

The insulation within the cable is one of the most important components of the cable, this is the essential component that separates the cable conductor from ground and sustains the electric field necessary for the transport of charge. MIND cable with Kraft paper insulation has proven long service experience and is considered a mature technology in HVDC systems. MIND has been installed in water depths of up to 1,600 m with operational voltage of 500 kV. In shallower waters, MIND has been installed with operational voltages of 525 kV and is in use on the longest in-service HVDC interconnectors (NorNed, NordLink, North Sea Link).

MIND cables have been used extensively with LCC-HVDC systems. To achieve bi-directional power control with an LCC-HVDC system, the polarity of each pole must be reversed; this means that only cables capable of withstanding polarity reversal can be used in a bi-directional project. Extruded cables have technical limitations in this regard, which means that only pressurised oil filled cables or mass impregnated (MI) d.c. cables can generally be used with LCC converters. Due to environmental risks, pressurised oil filled cables generally are not considered suitable for submarine installations. MIND cable is fully compatible with VSC-HVDC converters in addition to LCC converters, and has been successfully applied in a number of VSC projects.

Cable insulation materials are generally covered in Section E.2.2. For submarine cables, MIND and XLPE are considered to be the dominant insulation materials for both a.c. and d.c. systems. More detail on these two is provided in the following sub-sections.

E.8.2.1 XLPE

The use of three-core a.c. cables with an operating voltage of up to 220 kV is now considered relatively standard, whilst 275 kV is being widely proposed for future projects despite limited in-service experience at this voltage.

Like onshore cables, it is essential that for EHV cables the XLPE insulation is kept free from water, as discussed in E.2.2.1 XLPE for A.C Systems. Water blocking is therefore critical for submarine cable.

Extruded cable is generally considered to be more robust than MIND cable (like-for-like), and better able to withstand mechanical stresses. This is an important consideration in submarine applications where the mechanical stresses during installation and for dynamic cable applications can be considerable. Whilst XLPE cables have generally been installed in water depths of less than 100 m, there is no technical reason why they could not be used at depths similar to those achieved using MIND cable.

E.8.3 Metallic Sheath (Lead)

Unlike land cable systems, submarine cables are generally difficult to access and can be subject to high water pressure. At the time of writing this report, for cables with an operational voltage greater than 72.5 kV, lead is considered to be the only option in providing an impervious water barrier.

Submarine cables with an operational voltage below 72.5 kV generally use an aluminium foil with various layers of water blocking and an extruded layer of polyethylene to create a barrier to the penetration of water.

HVDC cables tend to only be used at transmission voltage levels and generally have a lead sheath.

For short circuit current carrying purposes, the lead sheath may be supplemented with screening wires.

E.8.4 Oversheath

A polymeric oversheath is applied over the metallic barrier. This provides protection against the environment and handling.

E.8.5 Armouring

Submarine cables are designed to withstand the stresses and rigours of installation through the inclusion of armour. Cable armouring is normally made of steel wires to provide the mechanical axial strength required during handling and installation operations. As a secondary benefit, the armour provides some limited protection for the cable from external mechanical damage. The armouring can consist of a single layer, but for deep water it is likely to consist of at least two layers. A careful selection of number of wires, wire diameter and materials, is required for cables to be installed in deep water.

Development of a lightweight alternative to steel is preferred that will add strength to protect the cable without adding significant weight. There is very limited in-service experience with these materials. The primary risks are the longevity of the material and its ability to withstand cable recovery, repair and reinstatement.

E.9 Submarine Cable Maintenance and End of Life

E.9.1 Inspection and Maintenance

While, in general, cable systems require minimal maintenance, for submarine cable systems some maintenance activities will need to be undertaken. These include route inspections, verification of burial depth, inspection of scour protections, and marine growth. Maintenance activities relate to both the cable as well as the surrounding installation environment. A significant portion of maintenance is related to the mechanical protection of the submarine cable.

There are three distinct ways of performing maintenance:

- Time based maintenance – maintenance based on a predetermined schedule.
- Condition based maintenance – preventative maintenance based on condition assessment of the system components.
- Corrective maintenance – repair or replacement of broken system components.

Time based maintenance in the form of offshore surveys is usually the basis of maintenance activities which then inform the need for condition based maintenance. Together, they are intended to avoid failures in service and reduce the need for corrective maintenance.

E.9.2 Repair

While cable systems are reliable, it is possible that cable failure will occur during the system's lifetime. Often this would have an external cause such as anchor strikes. If a cable failure is suspected, it is usual to perform a voltage test on the circuit to confirm that there is no other cause for the failure of the cable system. Once a failure has been noted, the type and location of the failure must be identified.

Depending on the type of fault, different diagnostic tests may be used to assist in determining the location of the fault. These diagnostic tests will give a rough indication of the location of the fault. Where possible, these diagnostic tests should be done from both sides of the circuit to give an indication of the accuracy of the tests undertaken. If these tests give similar locations, the results can be considered accurate and can reduce the length of circuit to be assessed in determining the exact location of the failure. In cases where the cable route is not well known, or

where multiple cables are in the vicinity, it is important to ensure the correct cable is identified for repair.

Following this, mobilisation of a repair vessel and crew can be undertaken. Mobilisation prior to fault identification is also possible, however delays in determining the fault location may result in significant costs related to standing time.

Repair of the cable requires the removal of the faulty section by cutting on both sides of the fault, installation of two joints between the spare cable and the remaining section of the original cable. After this, the cable is then laid back down on the seabed in a hairpin shape and suitable protection (whether burial, mattressing etc.) is put in place. Repairs to submarine cable systems require specialist vessels and equipment, and appropriately trained personnel. Depending on the availability of these resources, and potentially on the location of the vessel, repair times can be lengthy, usually in excess of several months.

E.9.3 Decommissioning

Different jurisdictions have varying regulations regarding cables no longer in service or having reached end-of-life. In some areas, the submarine cable may be left buried in the sea bottom. If the submarine cable is taken out of service, but in the near future might be commissioned again then leaving the cable in place is appropriate, provided there are no restrictions against it. However, in GB developers must generally plan for complete removal of an installation once it is out of service³⁵.

The lifetime of a submarine cable is normally longer than the lifetime of an offshore wind farm. Because of the longer life time, the submarine cable may be utilised for a new offshore plant provided it is in a suitable condition.

If submarine cables must be removed after decommissioning, many of the same issues regarding installation of cables must be considered. The methods of removal and the possible tools for de-burial and removal of the cable should be described including their influence on the environment. Cables buried very deep can be hard to remove. Decisions regarding burial depth at installation should consider the need for removal at decommissioning.

Over the lifetime of the cable system, new infrastructure may have been installed over the system. These crossings may also make removal of the submarine cable more difficult. Agreement between the involved parties should be made regarding the removal and should be implemented in a crossing agreement. Risk analyses should be made for the different processes to find the optimal solutions.

After removal of the submarine cables, the cables should be disposed of in an appropriate manner. A qualified company should separate the different cable layers and recycle as much as possible in an approved environmental manner. The metal (copper, aluminium, lead) can normally be reused. At present, techniques have not been developed to recycle the XLPE.

E.10 Submarine Cable Installation Works

E.10.1 Installation Vessels

Submarine cables are typically installed through the use of dedicated Cable Laying Vessels (CLVs). The largest bespoke cable laying vessels have capacities in the order of 10,000 tonnes of cable or greater. These vessels are very technologically advanced and there are a limited

³⁵

https://assets.publishing.service.gov.uk/government/uploads/system/uploads/attachment_data/file/679965/Decommissioning_guidance_2018.pdf

quantity available in the market. Some cable manufacturers operate their own fleet of vessels. As a result, cable installation campaigns must generally be planned several years in advance in order to secure availability. The depth of water in which the cable is to be installed may also mandate a particular type of vessel – for example, installation in shallow waters may necessitate a barge with low draught.

Use of a very large CLV with large carousel capacity is advantageous due to the longer cable lengths that can be installed. This reduces the potential quantity of field joints required in the submarine cable system. The impact of this is a reduction in the quantity of installation campaigns, reduced quantities of planned joints required, shorter installation durations, improved project program control and lower project risk.

For HVDC systems, the two cables are usually installed simultaneously, thus requiring a vessel with two carousels. They are “bundled” (strapped) together on the vessel prior to being laid. Examples of CLVs are shown in the following figures.

Figure E.11: Prysmian’s Leonardo da Vinci CLV



Source: “Prysmian Group’s Leonardo da Vinci cables installation vessel wants YOU!”, Prysmian Group, 2017. Available: <https://www.prysmiangroup.com/en/insight/projects/prysmian-groups-leonardo-da-vinci-cables-installation-vessel-wants-you>

Figure E.12: Nexans' Aurora CLV



Source: "CLV Nexans Aurora- The flagship of the Nexans fleet", Nexans, 2017. Available: <https://www.nexans.com/en/business/power-generation-transmission/subsea-interconnectors/CLV-Nexans-Aurora.html>

The cable will be buried if the risk of external damage due to anchoring, fishing activities, etc. is sufficiently large. As the day rate for the CLV is likely to be high, it is expected that a separate lower cost vessel will be employed to provide a post lay burial technique utilising a remote operation vehicle (ROV) or autonomous underwater vehicle (AUV) capable of withstanding the increased water pressure at increased depths. Examples of ROVs are indicated in Figure E.13.

Figure E.13: Global Marine ROVs

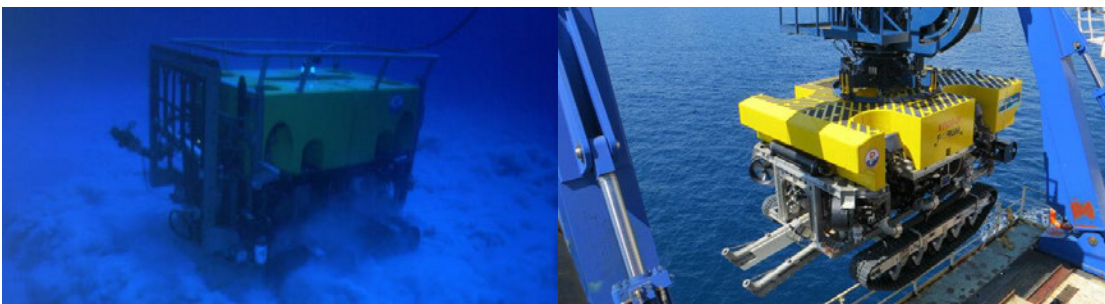

Source: Left hand image: "ST200 Series", Global Marine, 2023. Available: <https://globalmarine.co.uk/vessels-trenching-assets/st200-2/> Right hand image: "XT600 Trenching System", Global Marine, 2023. Available: <https://globalmarine.co.uk/vessels-trenching-assets/xt600-trenching-system/>

E.10.2 Impact of Environmental Conditions

It is singularly important that the installation method and environment are understood at the cable design stage and prior to contract award. This allows for type test requirements to be understood and any requirements for design development to be detailed prior to contract award. The cable must be designed to withstand the installation activities and the environment into which it will be installed.

The depth of water affects the cable design, installation, system cost and feasibility. The deepest submarine power cable installed to date is located at 1,600 m depth (SAPEI Interconnector – Italy) and has MIND insulation. There are no existing power cables installed at greater depths and very few at comparable depths. The installation of cable systems in very deep water provides a unique set of challenges.

Submarine cables are designed to withstand the stresses and rigours of installation through the inclusion of armour. As discussed above, cable armouring is normally made of steel wires although development of lighter alternatives is progressing.

A lighter cable will reduce longitudinal strain during installation and reduce installation risk. As the water depth increases, it is likely that the temperature of the installation environment will fall, resulting in the ability to use a smaller cross section of cable for the same rating. Alternatively, substituting aluminium conductor for copper may also be possible in these conditions. However, it is critical that the installation environment is well understood to avoid installing the cables in areas that may experience geothermal conditions (high ground temperatures) to ensure appropriate rating of the cable is maintained.

Aluminium is lighter and cheaper than copper, making it an attractive material for deep water installation. However, more cross-sectional area is required than the copper equivalent to achieve the same system ratings. This results in an increase in the cable diameter which makes the cable more difficult to handle. Aluminium also has a lower strength than copper, making it less resilient to the rigours of installation as compared to copper.

Particular attention must be paid during the cable lay process to reduce catenary loads and lay tension on the cable. Figure E.14 illustrates some of the factors that need to be considered and the effect that cable weight and installation depth can have on the ‘top tension’. This is the section of cable subject to highest stress. Heavy/deep cables are subject to high installation tensions which can lead to cable damage.

Figure E.14: Subsea cable installation

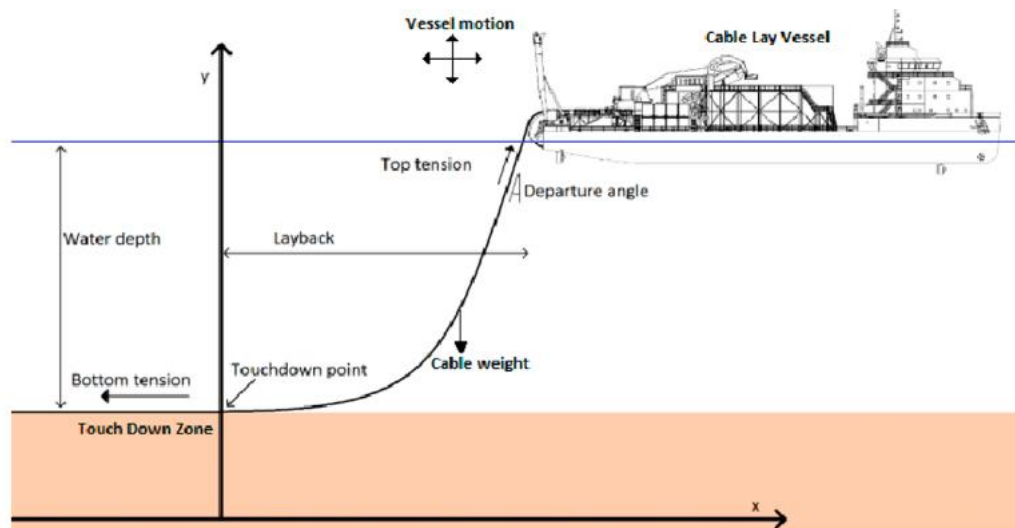

Source: Mamatsopoulos, V & Michailides, C & Theotokoglou, E.E., “An Analysis Tool for the Installation of Submarine Cables in an S-Lay Configuration Including “In and Out of Water” Cable Segments”, *Journal of Marine Science and Engineering*, 8, 48, Jan. 2020. Available: <https://doi.org/10.3390/jmse8010048>Corridor Requirements

With regards to the dimensions of the cable corridor, enough space must be allowed for the cable to be recovered during repairs. If a cable repair is required, a significant length of cable is necessary for the repair in addition to two sets of joints for each cable to be repaired. Where cables are bundled (typically in the case of HVDC), both cables will need to be cut, retrieved,

repaired and reinstated. The space required to perform a cable repair determines the distance required to be left between cable systems during installation so that a repair corridor is maintained. Industry standard offset distance for repair and maintenance is approximately 2-4x water depth, which is needed to safely bring the cable to the surface, repair the cable, and lay back down on the seabed in accordance with industry practice.

E.11 Application of the Technology

E.11.1 System comparison

As discussed in earlier sections, due to the capacitive requirements of HVAC systems, it is typically preferred to use HVDC solutions for long distance connections. These distances are likely for remote offshore windfarms, and also for interconnectors between large utility systems.

For shorter distances, the choice between HVAC or HVDC submarine cables should be considered on a project-by-project basis and requires consideration of:

- The MW capacity of the connection.
- The length of the offshore system.
- The length of the onshore system (particularly if the connection point is not close to the transition point).
- The appropriate voltage level for the system to be installed.
- The feasibility of installing HVDC converter stations onshore.
- The need for reactive power compensation equipment.
- The need to meet grid connection requirements.

E.11.2 Costs

Lay rates for the cable are likely to be similar to conventional installations and independent of water depth. The cable costs are also considered to remain largely similar across the route due to changes in the cable design offsetting the cost increases and reductions.

The primary factor affecting cost is currently considered to be risk, warranty and insurance. Depending on project specific requirements, there may also be additional costs associated with equipment for surveys and higher specification CLVs for installation, and additional tooling risk mitigation measures/procedures.

Where HVDC cables are bundled, should a cable failure occur, both cables will need to be cut to retrieve and repair them. This would result in the loss of transmission for the duration of the failure and repair works. To avoid this loss, it would be necessary to install the two poles separately and provide a metallic return so that the remaining pole could continue to operate whilst the faulted pole was repaired. The additional cost associated with the additional pole and installation campaigns generally outweighs the potential costs associated with outage and repair activities. A thorough risk analysis should be undertaken to understand the economic impact.

E.12 Anticipated Future Developments

As noted above, three-core HVAC XLPE submarine cables rated at 275 kV are expected to become more common. With regard to HVDC systems, XLPE cables have been pre-qualified up to 640 kV and it is expected that systems at this level will be installed in the future. We are also aware that companies are developing HVDC systems including metallic return conductors.

There are ongoing technology developments and research in power cables including ongoing research to develop lighter materials for the cable armour, which at the same time must provide a good mechanical protection. Some OEMs are understood to have a new design of armour for XLPE cable which they claim to be capable of being installed in water depths of up to 3,000 m, however there is no such installation to date.

As the world seeks to improve energy resilience through interconnection, it will be necessary to drive down costs which will improve project performance and viability. To achieve this, it is expected that research on new cable designs, advancements in CLVs capabilities, new survey techniques and knowledge of the environmental impacts on the very deep ocean will continue. This will likely improve the feasibility of installation of power cables.

CLVs are typically powered by fossil fuels, although it is understood that development is taking place in moving towards more sustainable options. One such vessel is currently being developed to be a battery powered hybrid vessel and is expected to cut NOX emissions by 85%³⁶. It is anticipated to be commissioned by 2025.

At the end of 2021, a framework for the provision of three 500 km HVDC submarine interconnectors to support power exchange among Sardinia, Sicily and Campania was awarded. The Tyrrhenian Link project³⁷ is scheduled for completion 2025-2028 and will see cables using MIND insulation technology deployed in water depths of 2,000 m using a new aramid armour. This armouring solution may reduce the costs through reducing the weight of the cable, however it is uncertain whether the cable will be more expensive due to the new material. It is understood that at least two OEMs offer this armour solution at this time.

³⁶ "Prysmian To Further Expand Its Cable-Laying Vessel Fleet", Prysmian Group, Nov. 2022. Available: <https://www.prysmiangroup.com/sites/default/files/corporate/media/downloads/pdf/press-releases/pr-new-vessel-2025-22-11-2022-eng.pdf>

³⁷ "The Tyrrhenian Link: The Double Underwater Connection Between Sicily, Sardinia And The Italian Peninsula", Terna, 2022. Available: <https://www.terna.it/en/projects/public-engagement/Tyrrhenian-link>

F. Tunnels

F.1 Introduction

This appendix provides technical information on the use of HV cable systems in deep tunnels as part of the GB NETS. Cables housed within tunnels offer an alternative to overhead lines for electrical power transmission, and have a long-established track record as an alternative to trenched cable systems. Typically, tunnels are used where specific constraints associated with access, space or system ratings would be challenging to overcome using any other method. The skills and experience to design, build, operate and maintain tunnel systems using personnel familiar with their characteristics are generally available in GB.

The purpose of this appendix to the report is to introduce some design, construction and operational aspects associated with cable tunnels, providing some context for comparison against other available technologies. This document covers the following topics:

- A description of the technology.
- The components behind the technology.
- Maintenance and decommissioning.
- Works associated with installation.
- Its application and uses.
- Anticipated future development.

F.2 Technology Description

The sections below highlight the key differences between simpler tunnels which can be achieved using pipe jacking and more complex tunnels which require a Tunnel Boring Machine (TBM). The optimal solution for a given application is highly dependent on site conditions and project requirements. In generic terms, a tunnel provides a sub-terranean link between two or more locations, thus avoiding above ground obstructions. Tunnels are typically three to four metres in diameter, and require ventilation shafts at regular intervals. An indication is provided in Figure F.1: Tunnel overview.

Figure F.1: Tunnel overview

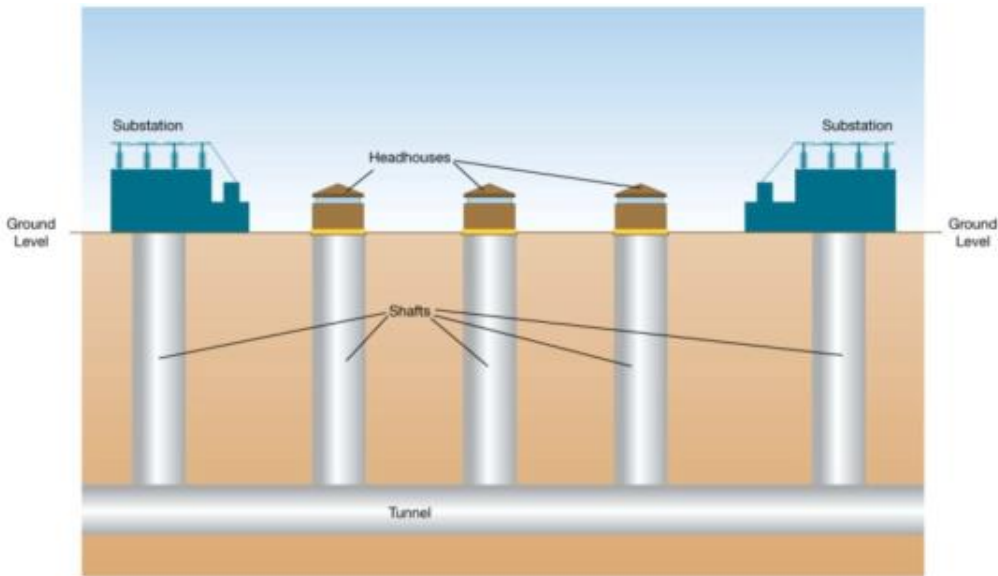

Source: “Electricity Transmission Costing Study: An Independent Report Endorsed by the Institution of Engineering & Technology,” Parsons Brinckerhoff, Jan. 2012. Available: <https://www.theiet.org/impact-society/factfiles/energy-factfiles/energy-generation-and-policy/electricity-transmission-costing/Headhouse>

For any tunnelling method, a headhouse building is required at either end of the tunnel, and for longer tunnels (>4 – 5 km) intermediate access/ventilation shafts with headhouses are also necessary. The headhouse is a building, generally sited directly over the access shaft, that controls access to the tunnel system via the shaft and allows access, retrieval or installation of equipment such as cables. Identifying the location and available land for headhouses is vital in determining a feasible tunnel route.

F.2.1 Shaft

The shaft is the vertical opening that allows equipment to enter or exist the tunnel system such as the tunnel boring machine. The bottoms of the shafts are also the drive and reception points for the tunnelling works during construction. Depending on the length of the tunnel system there may be multiple shafts along the route. This allows for ventilation and provides for multiple access points into the tunnel system and reduces the evacuation distance should there be an incident during cable inspection.

Figure F.2: Tunnel shaft insertion



Source: "London Power Tunnels", Mott MacDonald, 2023. Available: <https://www.mottmac.com/article/4660/london-power-tunnels-uk>

F.2.2 Head houses

Where shafts are retained after construction, then a headhouse building must be provided to control access and accommodate equipment.

The size of the headhouse is dependent on a number of variables. These include ventilation requirements, provision for safe and controlled access and egress, access for installation and maintenance of the cable system and accommodation for additional mechanical and electrical equipment necessary to service, monitor and maintain the cable systems and tunnel infrastructure. In some cases the headhouse will accommodate the fans required for forced ventilation of the tunnel.

Based on recent projects in the UK, an approximate footprint of a headhouse is typically 15 m by 15 m with a height of 10 m.

A typical example is illustrated in Figure F.3.

Figure F.3: Image of an example headhouse



Source: "Tunnels and Ventilation", Fereday Pollard, 2018. Available:
<https://www.feredaypollard.com/experience/tunnels-and-ventilation>

F.2.3 Tunnel

The tunnel is the underground structure that houses the cable systems and any other utilities. The key parts of a tunnel are:

- The bore, the physical space open within the tunnel.
- The lining, the support structure that prevents the deformation or collapse of the tunnel.
- The cable system, the cable and supporting infrastructure that is required to carry power through the tunnel.

The tunnel bore is required to be sized big enough to carry the required cable systems (generally two three-phase systems, but in some cases the tunnels are designed to carry additional cables) whilst still allowing for personnel to walk through for maintenance and inspection. For longer cable tunnels walking access is supplemented by small battery powered vehicles.

F.2.4 Cable system

The cable system is comprised of two main items:

- The cable that carries electrical power through the tunnel system.
- The cable infrastructure that comprises the support brackets and cable cleats.

Cables are fixed at intervals to wall-mounted brackets by cable cleats (clamps) and hang unsupported between these fixed points. A typical installation is shown in Figure G.4.

Figure F.4: Cables installed within a tunnel system



Source: "High Voltage Cable Cleats", Thorne and Derrick, 2023. Available: <https://www.powerandcables.com/high-voltage-cable-cleats-cables-tunnels-supporting-hv-cables/><https://www.powerandcables.com/high-voltage-cable-cleats-cables-tunnels-supporting-hv-cables/>

F.2.5 Ventilation

Recent UK cable tunnels have utilised forced ventilation to assist in removing heat generated by the cable losses and thus avoid the cable temperature exceeding its design capability. The ventilation also provides tolerable temperature conditions for personnel access and can be used to control smoke propagation in the event of a fire.

Cool air is drawn in from outside and passed through the tunnel, increasing in temperature as it passes over the warm cables. At the end of a tunnel section the warm air is exhausted to the environment using large extractor fans. The higher the rate of air flow the lower the temperature differential between inlet (which is fixed by ambient temperature) and exhaust (which determines the maximum tunnel temperature). Fans must thus be sized to achieve sufficient air flow to meet the design temperature limits of the cable system and conditions for personnel access. Temperature differentials are also increased as the spacing between ventilation shafts increases, thus necessitating larger fans.

An example of a tunnel ventilation fan is shown in Figure F.5.

Figure F.5: Tunnel ventilation system installation



Source: "Tunnel Ventilation Systems", DPH, 2023. Available: <https://dphmsl.com/portfolio/tunnel-ventilation-systems-lb-foster-crossrail/>

F.2.6 System comparison

Tunnel systems have advantages and disadvantages compared to a buried cable installation as described in Table F.1.

Table F.1: Comparison of cable tunnels and trenches

Attribute	Cable Tunnels	Buried Cable
System Accessibility	Access to tunnels is constrained (confined space training or camera system required for inspection purposes), but cables can be readily inspected.	Cables are difficult to access. Inspection/repair requires excavation.
Additional maintenance required	Ventilation, tunnel and headhouse systems will introduce additional maintenance requirements.	Route inspections are relatively straightforward.
Potential for future network expansion	Tunnels can be designed to accommodate future cable systems tunnel systems, but retrospective modifications are unlikely to be feasible.	It may be possible to lay additional cables alongside the original route (dependent on route constraints).
Potential to increase cable loading	Can accommodate some future load increases by increasing ventilation.	Load increase beyond existing design limit generally requires revised system.
Potential to have third party services	Tunnel system operators can potentially lease space to third party services.	Possible to add telecom or third-party cables if spare ducts are added.
Operational Requirements	Requires a fan system to maintain cooling.	Does not require any operational systems for use.
Typical use case	By exception where not technically feasible to use a buried cable.	Standard solution when a buried cable system is required.

F.3 Tunnel Design

The key technical considerations for power transmission in cable tunnel systems include the thermal limits of the cables, earthing arrangements and installation requirements. The discussion in the following sections covers the technical considerations that need to be controlled to maximise the throughput of the cable system. Reference can be made to Appendix E for details related to common aspects.

F.3.1 Tunnel Size Requirements & Routing

With regards to the dimensions of the cable tunnel, the tunnel must be big enough to allow for cable installation and maintenance whilst being small enough to control cost. Other tunnels or utilities must be avoided and installation must be at sufficient depth to avoid instability to buildings and services above. Due to the tunnel being underground, the concept of a cable corridor isn't quite the same as a trenched cable route (however an agreement is still required to run below private property).

The design needs to consider the geotechnical characteristics of the proposed route. A summary of the key geotechnical risks are:

- **Mixed face conditions:** Where tunnelling is undertaken at the interface between two strata, the ground conditions at the face of the tunnel is referred to as a "mixed face". This can cause difficulties in tunnelling when the geology varies significantly as the tunnel boring machine is set up for particular ground conditions. For pipe jacking, this can cause particular difficulties as the forces on one side of the pipe can be different to another and can therefore skew the direction of the pipe jack alignment.
- **Groundwater inflow:** The presence of groundwater flow is a significant risk to tunnelling activity. It can cause difficulties during tunnelling, since excessive water inflow must be removed, and in some circumstances can cause tunnel face failure or flooding of excavated tunnels and shafts. The appropriate tunnelling machine will need to be chosen to manage high groundwater inflows should they be identified.
- **Face stability:** The presence of sand and gravel layers can give rise to an unstable tunnel face. Compressed air may need to be injected to stabilise the face and prevent water ingress.
- **Presence of boulders:** Boulders may be encountered along the route. The impact of these boulders on the tunnelling machine will depend on the size of the tunnelling machine used. For a large tunnel-boring machine, the boulders can be dealt with by use of an appropriate cutting head. For a pipe jack, this could skew the alignment or even cause the machine to get stuck if the boulders are of significant size.

Above ground, shafts dimensioned for sending and receiving the TBM are required at either end of each construction section. Large temporary working areas are required, particularly at drive sites in order to handle the inward flow of construction materials (primarily tunnel lining components) and separation and outward flow of spoil.

F.3.2 Thermal ratings

Traditional cable installation involves burying cables directly in the ground, or pulling them into pre-installed ducts. In these cases, heat losses are dissipated by conduction through the surrounding soil. In a tunnel, cables are usually fixed to a racking system, and are thus surrounded by air. Cables in air typically have higher current ratings because heat is dissipated by convection/radiation, which is a more effective mechanism and thus allows higher loadings (and thus losses) to be sustained without overheating the cable.

There are a few critical factors that dictate the operational temperature of the cable system in a tunnel:

- Cable system load.
- Conductor size and material.
- Cable system design.
- Tunnel diameter.
- Rate of air circulation or speed within the tunnel.
- Tunnel inlet air temperature.
- Tunnel outlet air temperature.

For design purposes, the tunnel inlet air temperature must be considered as the highest possible ambient temperature that may be encountered throughout the lifetime of the cable system, whilst the outlet temperature should be maintained at a low enough temperature such that the cable does not exceed its design maximum temperature. When access is required the air temperature may have to be reduced further to ensure acceptable working conditions when personnel are present. These scenarios determine the maximum design operating temperature for the cable system and operational design criteria for the ventilation system.

F.3.3 Ventilation

Ventilation is provided in a tunnel via the use of a system of fans which determines the velocity of air flow in the tunnel system. The ventilation system must be sized to keep the tunnel exhaust air temperature within permissible limits under worst-case loading conditions. The ventilation may also have to provide smoke control to assist evacuation in emergency situations.

The greater the cable thermal losses and the longer the tunnel, the greater the volume of air that needs to be passed through by the ventilation system. The size and power of the fans needs to be able to move this volume of air, with consideration that input air temperature and cable loading will vary across the year and that worst-case conditions must be considered.

The cooling requirements can also be managed during the design stage by adding more ventilation shafts along the cable tunnel route.

The rating of the cable system can be increased or decreased by controlling the air flow within the tunnel, however there is a practical limit to the air flow which is determined by the capacity of the ventilation system. For a given air flow the achievable rating is determined by the maximum length of tunnel between inlet and exhaust shafts, the temperature of the inlet air and the permissible temperature of the air that is exhausted.

F.4 Installation Works

F.4.1 Deep Tunnels with TBM

Tunnel construction involves using a Tunnel Boring Machine (TBM), which excavates the ground in front of the cutter head and installs pre-cast concrete lining segments built into rings behind it. There are a number of design options for the TBM, the selection of which will depend on the outcome of ground investigations which will inform the operating conditions that are likely to be experienced. If the ground is impermeable it might be possible to use an open face rock machine, whilst in wet conditions an Earth Pressure Balance Machine (EPBM) can be used to support the face and to prevent water inflows.

A TBM uses bentonite slurry at the face of the chamber to stabilise the face during excavation works. Excavated material is then removed from the face in the slurry and separated at the surface before recirculation of the slurry. An example of a TBM is shown in Figure F.6.

Multiple drive and reception sites are required dependent on the length of the route and the construction strategy.

Figure F.6: Tunnel boring machine



Source: “Robbins Double Shield TBMs”, Robbins, 2017. Available: https://www.robbinstbm.com/wp-content/uploads/2017/05/Robbins-Spec-Sheet_Double-Shield-TBMs.pdf

F.4.2 Pipe Jacking

Pipe jacking is usually suitable for tunnel diameters of up to 2.5 m and is thus unlikely to be suitable for large transmission cables due to their handling requirements. The excavation process is similar to that used for a bored tunnel with a small TBM excavating and supporting the ground, however the excavation is then lined by precast pipes which are pushed behind the moving TBM from the bottom of the drive shaft. Telescopic rams push against the shaft wall to advance the newly installed pipe. This pushes the pipe into the ground, advancing both the TBM and the string of pipes through the ground until drive completion. The drive length is typically between 250-750 m but is dependent on ground conditions due to the skin friction which arises and jacking forces required to overcome this.

Cable installation requirements for this trenchless technique are similar to those for bored tunnels, hence very long system lengths are possible.

F.4.3 Set up Sequence

The tunnelling system starts with the excavation of a minimum of two shafts, a drive shaft for launching and servicing the TBM and another for reception of the TBM. Should the route length warrant intermediate shafts then these will also be excavated from ground level.

The TBM is lowered and removed in sections through the shafts via a temporary crane system, with final assembly at tunnel level.

F.4.4 Excavation

Once the TBM is in position the tunnelling works will begin from the drive shaft. This involves the continuous extraction of excavated soils from the tunnel (called ‘spoils’) and the stabilisation

of the tunnel by installing lining e.g. through pipe jacking or by installing pre-cast segments. Figure F.7 shows a completed tunnel prior to cable installation.

Figure F.7: Tunnel showing outer segments



Source: City East Cable Tunnel Sydney", Star Group, 2019. Available: <https://www.star-group.com.au/experience/tunnelling/tunnelling-projects/city-east-cable-tunnel-sydney>

F.4.5 Cable installation

Once the tunnel is bored and fitted out then the cable system can be added. Cables are typically installed through the use of motorised cable drums located at the top of a shaft (as illustrated in Figure F.8). Use of a very large drum with a high capacity is advantageous due to the longer cable lengths that can be installed, leading to reduced quantities of planned joints required, shorter installation durations, improved project program and lower project risk. However, there is a limit to the maximum drum size that can be moved by road transport and there are electrical design constraints that limit installation length to circa 1 km in many cases.

Figure F.8: Cable winching from drum



Source: "Prysmian Cable Systems Olympic Tunnel 400 kV"

The cables are installed by pulling the 'nose' through the tunnel. Conventional cable installations use a winch located at the end of the cable section pulling a winch bond (steel rope) attached to a pulling head at the end of the cable. However, safety considerations have led to the development of a tug system for installations of large cable in tunnels, thus avoiding the risks of long ropes under high tension in a confined space. The system for installation must be designed to ensure that cable pulling tensions do not exceed the maximum pulling tension defined by the cable manufacturer. The method can be labour intensive for the setup, final positioning of the cable system and demobilisation requiring a large number of operatives to work in a confined space.

Once the cable has been pulled into the tunnel then it must be lifted on to the support brackets. To reduce risks associate with manual handling of large cables the lifting has been mechanised, as illustrated in Figure F.9.

Figure F.9: Cable being lowered into tunnel



Source: "Prysmian Cable Systems Olympic Tunnel 400 kV", Prysmian

Figure F.10: Automated tunnel cable installation machine



Source: BBUSL

F.4.6 Environmental Impact

During the excavation works for tunnel and shaft construction, high volumes of excavated material, known as spoil, are produced. This has to be regularly removed from construction sites and requires a large number of vehicle movements which can cause an impact on the surrounding road network. For example, a 4 m diameter bore of 1 km in length will generate

spoil to fill around 1,000 large tipper trucks. The management of this spoil can also be costly as it either has to be taken to landfill or treated to allow it to be reused somewhere.

In addition to spoil removal, frequent deliveries of concrete and shaft/tunnel segments are required which adds to the total vehicle movements associated with tunnelling activities and impact on the surrounding road network.

During the tunnelling and shaft excavation works, small volume losses can occur which create ground movements at surface level. These ground movements can impact on existing infrastructure including other tunnels, surface utilities, overground railway tracks and buildings, and are an important consideration when tunnelling in an urban environment. The extent of these ground movements will depend on the construction technique, ground conditions and depth and size of excavations. Larger tunnels will cause greater movement, although this will likely be mitigated if works are undertaken in rock or deep below ground level. Monitoring of ground movements during construction will be required and, if significant, remediation may be needed.

Work on the shaft sites would also result in other impacts including noise, vibration and dust. Furthermore, the drive shaft would remain open for the duration of the tunnelling works which are typically undertaken five days per week, 12 hours per day and therefore have the potential to impact on nearby receptors (residential and business).

Other environmental impacts of tunnelling will need to be considered. Some of these aspects include cultural heritage, waste management, water ingress and discharge, and sediment control.

F.5 Operation, Maintenance and end of life

F.5.1 Operation

The primary difference between a tunnel system and a conventional buried cable system is the requirement for the former to have a ventilation system. This involves an ongoing cost to operate and maintain the tunnel ventilation system, however these costs can be reduced by ensuring that the fans only operate when necessary (i.e. during periods of sustained high circuit loadings).

F.5.2 Inspection and Maintenance

Whilst in general cable systems require minimal maintenance, some activities will need to be undertaken. These include route inspections along the cable tunnel to confirm its condition, and also the condition of the HV cable system and ancillary components.

In recent years the design strategy for tunnel systems has been to minimise the amount of installed fixed equipment by as much as possible. This is because any fixed ancillary equipment would itself require frequent maintenance and necessitate more frequent access to the tunnel. Instead, the use of portable equipment that can be carried in and out of the tunnel at each use is preferred. As a result, maintenance requirements are not significantly different to those of a buried cable system, with both systems only requiring personnel to patrol the length of the route for annual inspections, in addition to periodic testing and condition monitoring. For tunnel systems it is possible to visually check the cable systems from end to end.

F.5.3 Repair

While cable systems are reliable, it is possible that cable failure will occur during the system's lifetime. If a cable failure is suspected then the type and location of the failure must be identified by testing.

An advantage of cable systems installed within a tunnel is that once the systems have been made electrically safe, fault location can often be done visually by the repair crew. As such, diagnostic testing for fault location may not be as critical compared to a buried cable system. However, if visual inspection is not possible then different diagnostic tests may be used to assist in determining the location of the fault. These diagnostic tests will give only an approximate indication of the location of the fault, thus where possible these diagnostic tests should be done from both ends of the circuit to improve accuracy. If these tests give similar locations, the results can be considered accurate and can reduce the length of circuit to be inspected to determine the exact location of the failure.

Prior to mobilisation of the repair crew, the cable tunnel will need to be ventilated to reduce its temperature to a safe temperature limit for human operators to work on the system. Ventilation must be maintained throughout the work.

Repair of the cable typically requires the removal of the faulty section by cutting on both sides of the fault. This creates a physical space between the two ends of the conductor that must be filled. Hence a cable repair normally requires the installation of two joints between the spare cable and the remaining sections of the original cable.

F.5.4 End of Life

The service life of an XLPE cable system is expected to be 50-60 years, however as no EHV cables of this type have yet reached this age then this must be validated by service experience.

Options for cables at the end of their life include:

- Refurbishment of the tunnel and installation of a replacement cable system.
- Abandonment of the tunnel system.
- Repurposing of the cable tunnel for other utilities.

Given the trend of electrification to enable decarbonisation, replacement of the cable system would be a default assumption for cables at the end of their life.

As a tunnel system has an expected service life of 100 years, it is likely to undergo a cable replacement during its lifetime³⁸.

When cables are removed the process is similar to cable installation.

After removal of the cables, it is expected that they will be disposed of in an appropriate manner. A qualified company should be employed to separate the different cable layers and recycle as much as possible in an approved environmental manner. The metal (copper, aluminium, lead) can normally be reused. At this stage, the XLPE is not currently expected to be recycled but methods for the recycling of XLPE may be developed in the future.

F.6 Application of the Technology

F.6.1 Recent Applications

Tunnels for cable systems are typically undertaken due to some technical issue or physical obstruction precluding the use of a burial method. Recently at transmission level there have only been a small number of such projects implemented, although there is existing tunnel infrastructure already in operation at both transmission and distribution level. The recent

³⁸ As an example Singapore has completed a tunnel with a design life of 120 years which houses a cable with a 30 year design life. See:

[Singapore's deepest transmission cable tunnel system is almost ready | Geoengineer.org](https://www.geoengineer.org)

projects include London Power Tunnels³⁹ (with the first phase of works being completed in 2018, and the second phase of works currently under construction). In this instance tunnels were necessary as existing infrastructure at surface level prevented installation of the necessary number of cables to the required locations. Several other projects have been undertaken in London and elsewhere at distribution level, with the same drivers. Figure F.11 shows the extent of the tunnel network which will be constructed during phase 2. This comprises approximately 32 km of 3 m diameter tunnels.

Figure F.11: London power tunnels phase 2

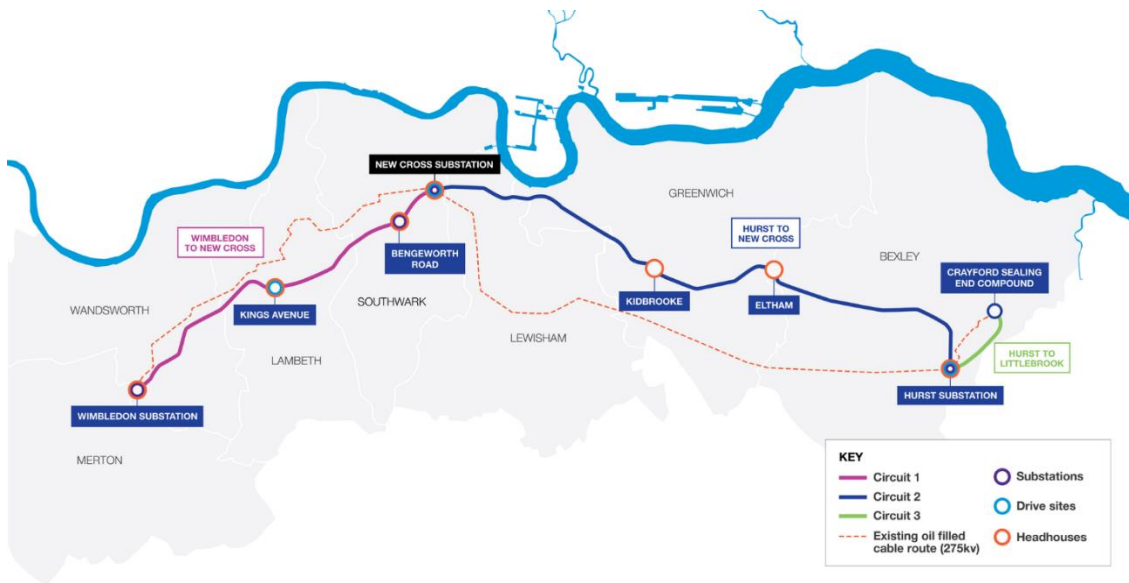

Source: "London Power Tunnels", National Grid, 2023. Available: https://www.nationalgrid.com/electricity-transmission/sites/et/files/images/London%20Power%20Tunnels%20Map_0.png

A further project in Snowdonia National Park⁴⁰ has recently been awarded with construction expected to commence in 2023, illustrated in Figure F.12. In this instance the purpose of the project was to remove the overhead lines and their associated visual impact from the national park. These overhead lines currently cross an estuary and no other practical option was identified for achieving this crossing. The tunnel is expected to be approximately 3.4 km in length, with a diameter of 3.5 m.

³⁹ <https://www.nationalgrid.com/electricity-transmission/network-and-infrastructure/london-power-tunnels-project>

⁴⁰ <https://www.nationalgrid.com/electricity-transmission/network-and-infrastructure/visual-impact-provision/eryri>

Figure F.12: Snowdonia visual impact project

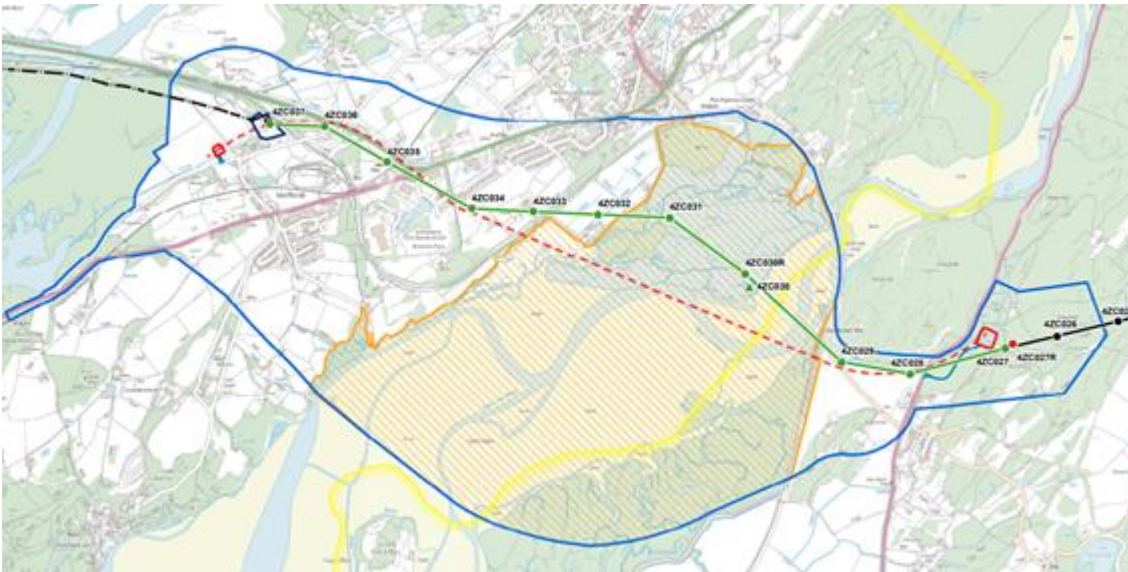

Source: “National Impact Provision of Snowdonia Project”, National Grid, 2020. Available: <https://www.nationalgrid.com/electricity-transmission/document/143261/download>

F.6.2 Costs

An exercise was undertaken by the Infrastructure and Projects Authority, UK Government, to analyse costs from past tunnelling projects to understand the relationship between tunnel diameter and total tunnel volume versus cost for both transport and utility tunnel projects. This case study was published in 2018 but should be treated with caution due to the limited number of projects which were analysed as part of this study, and the significant change in costs since 2018. The cost indicated is for the tunnelling activities only, and other costs including the cable system would need to be added on top of this.

Figure F.13: Cost versus diameter of utility projects

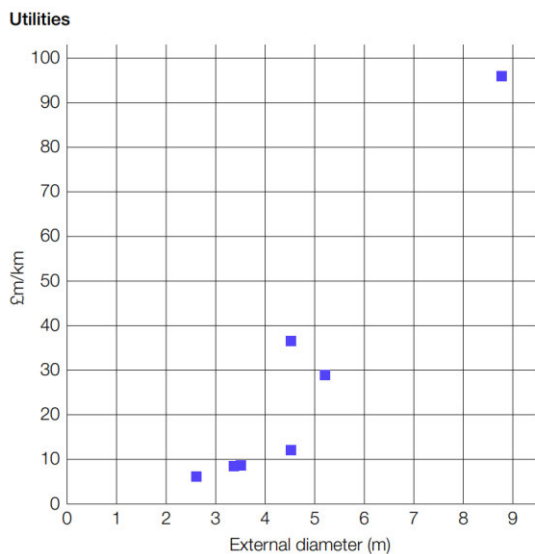

Source: “Case Study: Benchmarking tunnelling costs and production rates in the UK”, Infrastructure and Projects Authority, 2018. Available: https://assets.publishing.service.gov.uk/government/uploads/system/uploads/attachment_data/file/762006/CC_S207_C_CS1118018748-001_Benchmarking_tunnelling_costs_and_production_rates_in_the_UK_Web_Accessible.pdf

As can be seen, the cost associated with the construction of the tunnel infrastructure itself is significant, even before the costs of the supply and installation of the cable system are considered. Cable tunnel systems are almost always more expensive than trenched cable installations. Further information in respect of costs is given in Section 4 of this report, with the main cost components showing in Table F.2.

Table F.2: Main cost components of tunnel system

CAPEX Components	OPEX Components
Project Development work including initial designs, surveys, ground investigations, procurement/tendering, stakeholder engagement.	Costs associated with regular inspection and maintenance of the tunnel and cable system.
Planning permissions, land acquisition, permits, consents.	Inspection and maintenance costs associated with secondary systems such as ventilation and lighting.
<ul style="list-style-type: none"> ● Detailed Design and route proving. 	Provision and maintenance of access and egress equipment, emergency escape equipment and similar.
<ul style="list-style-type: none"> ● Construction costs associated with <ul style="list-style-type: none"> – Headhouses. – Shafts. – Tunnels. 	Electricity costs associated with powering the secondary systems such as lighting and ventilation.
Cost of secondary systems such as ventilation, lighting drainage.	Losses associated with the cable tunnel system.
Procurement of cable system.	Lifecycle costs such as replacement of fans.
Cable installation.	-
Testing, commissioning and energisation.	-

Costs and project durations for cable tunnel systems are highly variable due to their geographically specific nature which introduces a significant quantity of variables including ground conditions, tunnelling method, tunnel dimensions (e.g. length & diameter), number/size and depth of shafts, availability of plant, access requirements, logistics and contractor experience.

There can also be large differences between costs for similar projects of similar size/length influenced by geographic factors, availability of specialist skilled labour, ground conditions and risks, or client/project specific requirements. In addition, costs and project durations are also dependent on the constrained market availability for items such as specialised plant and suitably capable contractors and manufacturers. In some cases, for specific products, there may be only one suitably experienced or capable contractor/supplier. The combination and accumulation of these factors contribute to the magnitude of project risk present.

F.7 Anticipated future developments

Future developments for cable tunnels are expected to involve increasing levels of automation.

Concepts such as “Hyper-Tunnels” have been proposed which involve automated micro tunnel excavation to allow for the tunnel casing to be cast in situ. This concept is illustrated in Figure F.14.

Figure F.14: Microbores being drilled for hypertunnel concept

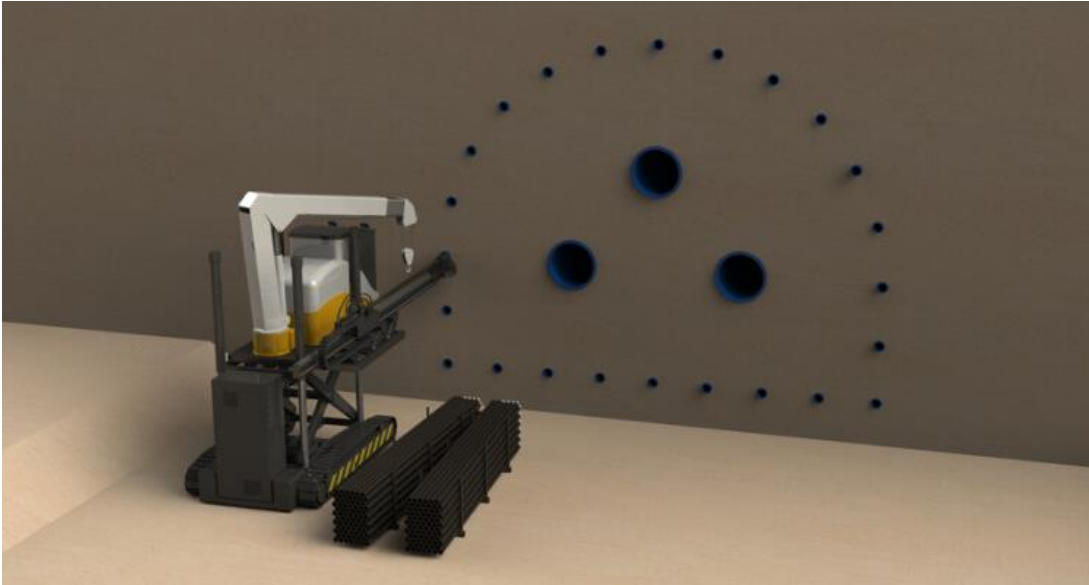

Source: "Vinci takes stake in swarm tunnelling start-up", The Construction Index, 2022. Available: <https://www.theconstructionindex.co.uk/news/view/vinci-invests-in-swarm-tunnelling-start-up>

This is followed by tunnel excavation, which reveals the precast tunnel casing, Figure F.15.

Figure F.15: Rail installation for London power tunnels 2



Source: "London Power Tunnels", Skanska, 2023. Assessible: <https://group.skanska.com/projects/200056/London-Power-Tunnels/downloads>

Subject to the development of superconductor technologies and the inclusion of gas-insulated lines in the transmission system, the cable tunnels may be repurposed in the future to use those technologies rather than the typical cable technologies.

G. High Voltage Direct Current

G.1 Introduction

This appendix provides a general overview of High Voltage Direct Current (HVDC) technology, and information pertaining to converter stations. Information in relation to subsea cables, including HVDC, is covered in Appendix E of this report. Costings for both aspects are discussed in Section 4 of this report. The purpose of this appendix to the report is to explain the difference between a.c. and d.c. technology, and introduce some design, construction and operational aspects associated with HVDC technology, providing some context for comparison against other available technologies. The following topics are covered:

- A description of the differences between a.c. and d.c. technology.
- A description of the technology.
- Typical HVDC configurations and layout.
- Application of the technology.
- Lifecycle considerations including maintenance and decommissioning.
- Principal cost components.

G.2 a.c. vs d.c. Transmission

As the electrical power industry developed from small-scale local suppliers to larger networks, alternating current (a.c.) transmission quickly became established as the preferred method for bulk power transmission because it enabled power transformers to step-up voltage to a level that allowed for efficient transmission over distance and step-down to convenient levels to supply customers. This is not possible with direct current (d.c.) systems as the operating principles of electromagnetic transformers are reliant on alternating current.

D.c. transmission was never entirely dismissed, since it was recognised that it had advantages in some circumstances. However, whilst high voltage d.c. (HVDC) cables/lines are generally more efficient for long-distance transmission than their a.c. equivalents, HVDC power sources were not available and for many years the available technology for converting from HVAC to HVDC and back to HVAC (rotary converters and early mercury arc rectifiers) was not suitable for high voltage/high power applications.

The first practical application of HVDC transmission, using controllable mercury arc rectifiers to convert from a.c. to d.c. and then 'invert' the d.c. supply to feed an a.c. network was in the 1950's. This led to development of rectifiers/inverters capable of handling several hundred MW and the implementation of a number of HVDC transmission schemes. Mercury arc rectifiers had a number of disadvantages, and were replaced by solid-state thyristors from the mid-1970's. More recently a new generation of converters based on Insulated Gate Bipolar Transistors (IGBTs) has been developed.

As well as reducing losses, one of the key differentiators between HVAC and HVDC technology is in situations where long cables must be used, such as for subsea power transmission, and is associated with the electrical characteristics of the power cables. Due to their construction all cables exhibit a characteristic known as capacitance, which acts in a manner analogous to a small internal battery that must be charged as the applied voltage increases and discharged as it decreases. This requires a "charging current" to flow within the conductor of the cable, using capacity that could otherwise be used for the useful transmission of active (real) power. In alternating current systems, the charging and discharging occurs continuously (in Europe the

system operates at a frequency of 50 Hz, meaning that charging and discharging occurs 50 times per second). In direct current systems the voltage remains constant during normal operation, thus the cable only needs to be charged once at the start of operation.

The cable conductor must be sized to accommodate both the charging current and the 'useful' current required to transmit the active power. The level of charging current which is required increases linearly with length and therefore, for an a.c. cable, the longer the cable length the larger the conductor needs to be to accommodate the combined effect of the charging and useful currents. However, there is a limit to the size of conductor that can be incorporated in a HV cable and ultimately there comes a point where the length of a system is so long that a significant proportion of the capacity of the conductor is utilised for the charging currents and the useful power transmission capacity is limited such that the cable system is not economically viable. Hence there is a physical limitation as to the maximum length which an a.c. circuit can be without using intermediate stations to inject charging current. d.c. cables, on the other hand, only carry active current meaning that their length is in practical terms unlimited.

A further consideration is that the charging current in an a.c. cable generates resistive losses in the same way as the useful current, thus as the length of an a.c. cable system increases the transmission losses increase at a higher rate than a d.c. cable system.

The charging currents in a.c. cables are generally considered as 'reactive power', differentiating them from the useful currents which represent 'active power' flows. Reactive power is not generated and consumed in the same way as active power, but is exchanged with other devices connected to the power network (as the a.c. voltage increases 'inductive' components absorb charging power, but other 'capacitive' components supply that power; as the voltage falls this process is reversed). Many TSOs impose limits on the amount of reactive power that can be exchanged with their network, thus long cables generally require compensation systems (i.e. devices that can exchange reactive power with the cable) such as reactors to be installed at the terminal points. In some cases, such as on the Hornsea One Offshore Windfarm connection, it has been necessary to install mid-point reactive compensation to limit the flow of charging current in any section of the cable. As the installation of such measures increases the overall cost of the solution, it may be more economic (and efficient) to apply HVDC technology.

The effect of cable charging currents (reactive power) on the active power transfer capacity of cables is illustrated in Figure G.1. This compares the active power transfers available for a.c. and d.c. cables of identical conductor size and varying length.

Figure G.1: Transmission capacity versus cable system length

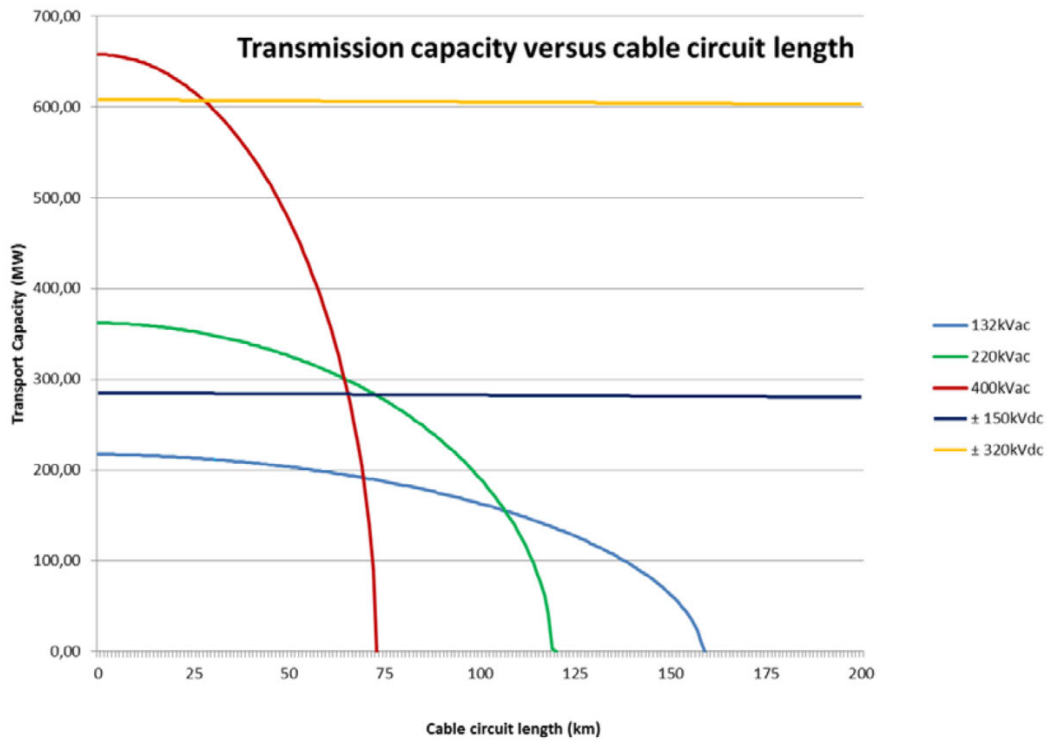

Source: Reprinted with permission from CIGRE, Offshore Generation Cable Connections, Technical Brochure 610, © 2015.

This comparison assumes a common ampacity of 950 A for all the cables, independent of voltage and a.c. or d.c. operation, with the a.c. cables assumed to be compensated from one end. As an example, offshore systems often use 220 kV a.c. cables. Using Figure H1, this requires a charging current of approximately 8 A per km when connected to a 50 Hz power system, thus for a 120 km length, the entire 950 A capacity is required to supply the charging current. Whilst this can be mitigated by compensating from both ends of the cable (i.e. feeding 475 A from each terminal of a 120 km cable), the maximum practical length of a 220 kV a.c. cable is in the range of 100 to 120 km if significant derating is to be avoided.

Charging currents increase with transmission voltage (since more energy is required to charge the internal 'battery' to a higher voltage); thus, in this example 400 kV cables are practically limited to a length of 50-60 km when connected to an a.c. system, even if both ends are compensated.

It can be concluded from the above that the effect of cable charging currents imposes a practical limit on the maximum length of a.c. cable circuits, and that this is a significant constraint at the highest transmission voltages. Consequently, implementation of long cable circuits necessitates the use of HVDC technology, and this is becoming particularly prevalent where offshore installations are concerned, such as the connection of large offshore windfarms or the installation of offshore systems to reinforce the onshore network (embedded links) or interconnectors.

There are other reasons that HVDC may be preferred over an a.c. solution, some examples being:

- HVDC can be used to connect two asynchronous networks, or networks operating at different frequencies.
- Depending on the configuration, only two conductors may be required (positive and negative) as opposed to three phases for an a.c. system, thus cable costs may be lower.
- The resistance of each d.c. conductor is lower than that of an equivalent a.c. conductor and only two conductors are used (rather than three for an a.c. system), thus bulk power transfer over very long distances is more efficient with a HVDC solution.
- Greater controllability of power flow over the specific link compared to a.c. circuits, also offering control features that can aid system operation.
- Reactive compensation equipment is not required for HVDC cable.

In respect of cost considerations, for an a.c. solution of a given capacity the fixed cost component (i.e. independent of circuit length) is relatively low and primarily comprises the grid connections at either end. The variable cost component then increases depending on the circuit length. For HVDC on the other hand, there is a relatively high fixed cost element to construct the converter stations with a variable cost component depending on circuit length, which increases at a lower rate than that of an a.c. solution. As such there is usually a “break even” distance after which the a.c. solution becomes more expensive than the HVDC solution. Whilst the exact distance at which this occurs is highly project dependent, ENTSO-E⁴¹ estimates that for cables it lies within the range 40-150 km, and for overhead lines 500-800 km. The break-even distance is indicated graphically in Figure G.2.

Figure G.2: Graphical representation of break-even distance

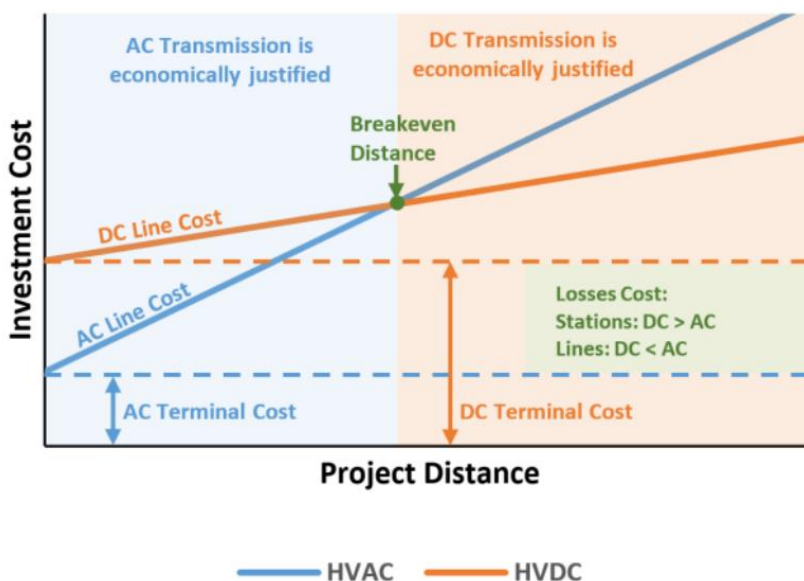

Source: “HVDC Transmission: Technology Review, Market Trends and Future Outlook”, Iberdrola Innovation and The University of Strathclyde, Available: <https://core.ac.uk/reader/210996200>

To date, the majority of HVDC systems have been constructed as point-to-point installations (i.e. using two converter stations, one to “send”, and one to “receive”), since this simplifies the control of the overall system. However, there is increasing interest in the implementation of multi-terminal HVDC systems with one such system recently commissioned in China, and the SHETL owned Caithness-Moray HVDC link being extended to incorporate an additional

⁴¹ “HVDC Links in System Operations”, ENTSO-E. Dec. 2019. Available: https://eepublicdownloads.entsoe.eu/clean-documents/SOC%20documents/20191203_HVDC%20links%20in%20system%20operations.pdf

converter station on the Shetland Islands forming a three-terminal HVDC link. This technology enables development of multi-purpose interconnectors (MPIs) with an example of their use being to connect multiple offshore wind farms, creation of “energy islands”, or incorporation of offshore windfarms into cross-border interconnectors. This design philosophy for MPIs is still being developed, with the GB regulatory environment also in the process of being defined, however several “pilot-projects” are currently proposed.

It should be noted that the power rating of MPIs is currently constrained due to unavailability of practical HVDC circuit-breakers (current designs are complex, high-cost and require a large footprint). Consequently, it is not possible to discriminate all faults on the HVDC network and the entire network may need to be taken out of service temporarily for a fault on one component.

G.3 Technology description – HVDC

G.3.1 Technology Overview

A point-to-point HVDC installation requires the following main components:

- A converter station, acting as a rectifier to convert a.c. to d.c.
- One or more pairs of HVDC conductors (underground cable or overhead line) to transmit the power to its destination.
- A second identical converter station, acting as an inverter, to convert the power back from d.c. to a.c.

The converter stations at either end are identical (i.e. they can operate as rectifier or inverter) and their controls determine the direction of power flow.

There are two main types of HVDC converter station technology:

- Voltage source converter (VSC).
- Line commutated converter (LCC), also known as current source converter (CSC).

This designation refers to the type of power electronics that are utilised within the station. CSC is sometimes referenced as ‘classic’ converter technology and uses solid-state switching devices known as thyristors. The converter control system is able to turn these switches ‘on’ at the desired point in the a.c. cycle but they rely on the system to turn them ‘off’ when the current flow passes through zero (a process known as commutation). VSC is a more recent development, with first commercial use in 2000, and is based on Insulated Gate Bipolar Transistor (IGBT) power electronic switches. These switches can be turned ‘on’ and ‘off’ by the converter control system at any point in the a.c. cycle. The operating characteristics of the VSC converter requires fewer associated a.c. components than a LCC type, resulting in a decreased footprint, and has less interaction with the a.c. system, allowing the use of a VSC converter where LCC would be technically incompatible. Whilst historically VSC converters had higher losses and increased capital cost when compared to LCC, recent design developments and market conditions have resulted in the costs of VSC technology falling and efficiency increasing to a level similar to those of LCC.

In LCC installations the power electronic valves can be controlled to achieve desired real power dispatches, however as the thyristors can only be turned on and off once per cycle this limits the capability of LCC converters to respond during transmission system disturbances. Also, LCC converters are unable to contribute to system voltage control and can require additional control measures to mitigate their impact during system disturbances.

In VSC systems the power electronic valves can be turned both on and off at any point in the cycle and can thus be controlled to respond dynamically to system disturbances, thus providing

valuable grid-forming capability. Furthermore, VSC converters are able to provide fast-acting voltage control both in normal operation and in response to disturbances.

A significant drawback of a VSC converter has been the available power capacity. Due to technical differences between thyristors and IGBTs LCC systems can operate at higher powers than VSC systems. The consequence is that a +/-525 kV LCC system can be designed to carry 5 GW, whilst a VSC system operating at the same voltage can only transfer 2 GW. However, since HVDC cables are also limited to carrying circa 2,000 A, the power limitations of VSC converters are not expected to be a significant issue in many cases.

It is believed that the majority of future HVDC converter stations in GB are likely to be VSC technology unless a very large connection capacity is required. Some typical characteristics of technology are given in Table G.1

Table G.1: LCC and VSC characteristics

Characteristic	VSC	LCC
Type of Valve	● IGBT.	● Thyristor.
Current Carrying Capacity	● Current carrying capacity presently restricted to around 2,000 A.	● Current carrying capacity up to around 5,000 A.
Operating Voltage	● Typically up to 525 kV (limited by cable technology).	● Typically up to 800 kV (with OHL transmission).
Commutation	● Self-commutating, without reliance on the a.c. system.	● Rely on the presence of an a.c. system for commutation.
Controllability and Flexibility	<ul style="list-style-type: none"> ● Active and reactive power control. ● Able to provide voltage control. ● Able to provide black start capability. ● Direction of power flow can be reversed by altering direction of current flow providing for fast response times. ● More resilient to network faults as compared to LCC solution. 	<ul style="list-style-type: none"> ● Active power control only. ● Unable to provide voltage control. ● Unable to provide black start capability. ● Direction of current flow is fixed. In order to reverse direction of power flow, voltage polarity of poles has to be reversed. ● Network faults can interrupt operation of LCC systems under some circumstances.
Reactive Compensation	● Does not require reactive compensation.	● Absorbs reactive power and therefore generally require reactive compensation equipment to be installed.
Harmonic Filters	● Less likely to require harmonic filters as compared to LCC solution.	● Always requires harmonic filters.
Losses	● Typically considered in the region of 1% full load losses per converter station, although modern installations are achieving an improvement on this value.	● Typically considered in the range of 0.6% to 0.8% full load losses per converter station.
Noise	● Lower levels of audible noise as compared to LCC solution.	● Higher levels of audible noise as compared to VSC solution.
System Strength	● Are able to operate in networks with low short circuit levels (weak networks).	● Are less compatible with weak networks as compared to VSC solutions.
Cable Compatibility	● Compatible with both XLPE and MI cable types.	● Incompatible with XLPE cable, generally restricted to use with MI cable (refer to Appendix E).
Converter Station Size	● Lower footprint as compared to LCC solution, typically considered to be around 40% less.	● Typically require greater footprint as compared to VSC solution.

G.3.2 HVDC Configuration and Layout

There are two main VSC HVDC converter configurations:

Table G.2: VSC HVDC configurations

Name	Description
Monopole	<ul style="list-style-type: none"> ● This uses a single HVDC pole fed by a single transformer per phase. ● Modern systems use the symmetrical monopole configuration whereby each conductor operates at half the rated voltage.
Bi-pole	<ul style="list-style-type: none"> ● In this configuration there are two separate poles, each fed by separate transformers, each operating at opposing voltages (e.g. one at +525 kV, one at -525 kV). ● In “rigid bi-pole” configuration there is no metallic return conductor. If one converter pole is out of service, half the rated power can generally be achieved so long as both conductors are available. ● In “full bi-pole” configuration a metallic return conductor is provided. Under normal running arrangements this is not expected to carry any current, but if there is an outage on one of the main conductors then the system can generally be reconfigured to carry half the rated capacity using the metallic return.

Both monopole and bi-pole configurations are commonly used and have established service histories worldwide. Monopole configurations have a smaller footprint when compared to that of bi-pole and are generally lower cost, however there are technical constraints which limit the practical operating voltage (± 400 kV is the current maximum for a monopolar converter) and thus the maximum power transfer capacity.

Furthermore, whilst both configurations offer good reliability and availability, a bipolar configuration provides better resilience, as it can continue to operate at approximately 50% capacity when one pole is out of service provided that both cables are available. Note that if one, or both, cables are out of service then neither a monopole system or a bi-pole system would be able to operate (assuming a system with two cables, which is normally the case).

The main areas of a typical converter station include:

- DC hall (positive and negative side).
- Valve hall (positive and negative side).
- Control room.
- Converter transformers and transformer halls.
- AC switchyard and filters.
- Coolers.
- Spare parts storage.

The footprint requirements for a converter station are largely determined by the converter valve halls and the valve reactors. The valve hall size is determined by the number of series connected converter modules and by the electrical clearances needed between phases and to the ground. DC voltage, therefore, largely defines the footprint of the converter station, as increase of DC current, or power rating, will not cause much change. A perimeter of the station compound can vary from 150 m to 500 m in length or width depending on the technology choice and capacity of the connection. For example, a modest-capacity VSC system may have a footprint in the region of 200 m x 150 m whereas a larger capacity LCC system may require a footprint of 500 m x 400 m. Figure G.3 below shows an indicative layout of a 2,000 MW ± 525 kV bi-pole VSC HVDC converter station.

Figure G.3: Indicative layout of VSC bi-pole converter station

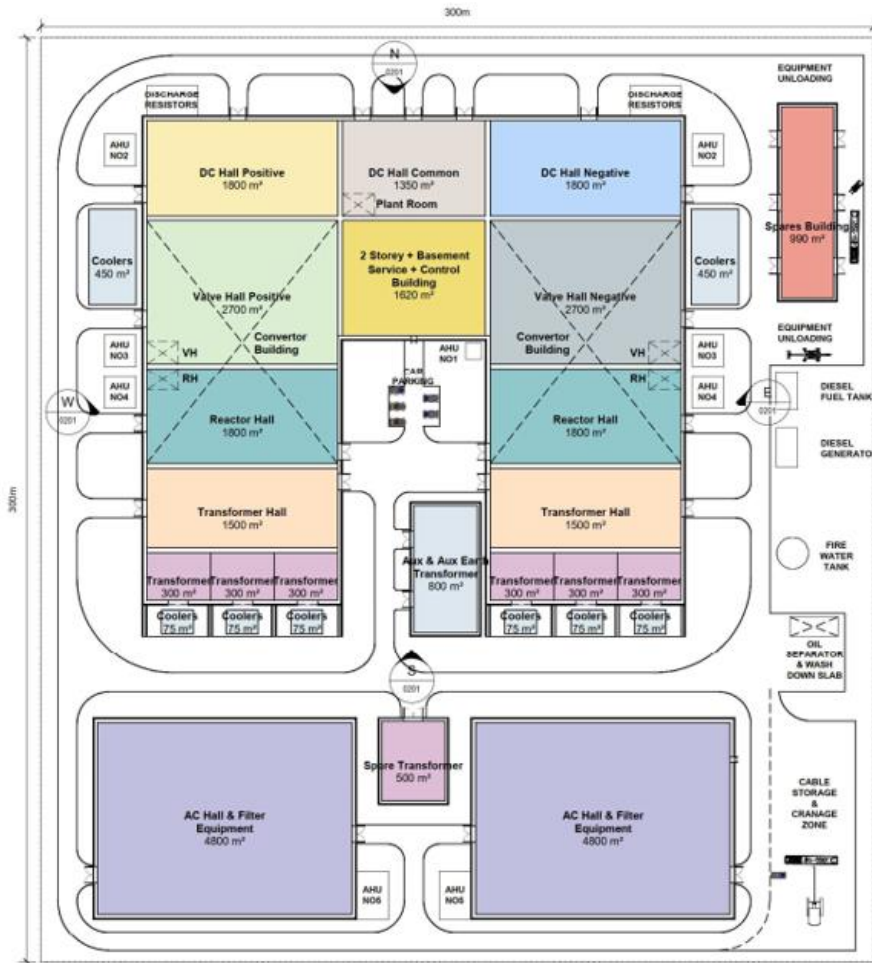

Source: Mott MacDonald

Figure G.4 shows the NordLink HVDC Bi-pole VSC station at Wilster, Germany. The NordLink interconnector is a 623 km link between Germany and Tonstad in Norway with a capacity of 1,400 MW at ± 525 kV d.c.

Figure G.4: NordLink HVDC converter station



Source: "NordLink", Tennent, 2023. Available: <https://www.tennet.eu/projects/nordlink>

Whilst GB HVDC installations have been limited to installations between pairs of onshore points, they are now being considered for offshore use including connection of large offshore windfarms as proposed in the HND and referenced in Section 2 of this report. Whilst this is a new application in GB, it is a well-proven approach in other European countries where several offshore platforms incorporating HVDC technology have already been installed, facilitating connection of offshore wind to the onshore network. In these instances the layout of the substations tends to be more compact and constructed on multiple levels, in order to reduce the overall dimensions of the offshore platform. In onshore installations construction on multiple levels is usually avoided for visual amenity/planning reasons. An example of an offshore HVDC platform is shown in Figure G.5.

Figure G.5: DoIWin Alpha offshore platform



Source: "DoIWin1", Hitachi Energy, 2023. Available: <https://www.hitachienergy.com/about-us/case-studies/dolwin1>

G.3.3 Applications

Table G.3 provides an indication of typical applications for HVDC technology.

Table G.3: Typical HVDC applications

Name	Description
Interconnector	<ul style="list-style-type: none"> ● Point-to-point system typically providing a connection between two different countries. ● Likely to provide a connection between two different AC synchronous networks which may be operating at different voltages and frequencies to each other. ● There are currently eight interconnectors which are operational in GB providing connections to France, Ireland, Netherlands, Norway and Belgium with others in development.
Embedded HVDC Link	<ul style="list-style-type: none"> ● Point-to-point system typically providing an offshore connection, the purpose of which is to reinforce the onshore network. For example, this could be a connection between the transmission system in Scotland and England using an offshore route. ● There are currently two embedded HVDC links in operation in GB including the West Coast HVDC link, and the Caithness-Moray HVDC link with others under development as per the HND and as described in Section 2. ● Can sometimes be expanded to a multi-terminal solution, such as Caithness-Moray where a third terminal is under construction.
Onshore Link	<ul style="list-style-type: none"> ● Typically a point-to-point system providing a long-distance/high-power onshore connection within a country. ● Not currently used in GB but common-place in other countries. ● Multiple such links are currently under construction in Germany to provide a link between the North of the country which has significant renewable generation, and the South which has high demand.
Multi-terminal link	<ul style="list-style-type: none"> ● HND proposes the use of multi-terminal HVDC links, for example with two onshore converter stations, and one offshore converter station (see Section 2) with one such system under construction and others in development. ● Would allow connection of offshore windfarm with the option for power flow to two different onshore locations, or operation as an embedded link. ● Some elements of the technology are still not fully mature, and it would currently be necessary to procure all terminals from the same OEM due to proprietary aspects of the technology. We are aware of ongoing developments which may lead to a vendor agnostic solution in the future.
Back-to-Back	<ul style="list-style-type: none"> ● Primarily used where it is necessary to connect two asynchronous networks, or networks of different frequencies, within the same country. ● Typically deployed on the boundary between the two networks, without the need for a cable in between.
Offshore to Onshore Connection	<ul style="list-style-type: none"> ● Proposed as a method to connect high-capacity offshore windfarms to the onshore network. ● Not currently used in GB but commonplace elsewhere. ● Consists of a single offshore converter station on a platform, and a single onshore converter station.

G.3.4 Lifecycle Considerations

HVDC systems typically have a life expectancy of 40-50 years, with some parts of the converter stations (valves, control systems, transformers) likely to need mid-life replacement or refurbishment after 20-25 years. Table G.4 provides an indication of typical aspects which may need to be considered in respect of lifecycle costs.

G.4 Principal Cost Components

HVDC installations in GB and across the world can vary greatly in size, configuration and use case. Each connection is unique, built to meet the particular requirements of the transmission system and developer. Therefore, assigning typical costs to HVDC installation in general can be difficult. Further details in respect of costs are presented in Section 4. However, the following are some of the typical cost components for consideration (cost components associated with cables are discussed elsewhere within this report).

Table G.4: Principal HVDC cost components

Title	Description
Development Costs	<ul style="list-style-type: none"> ● Initial concept, feasibility and design costs. ● Stakeholder engagement activities. ● Legal, environmental, land purchase, planning permission etc. ● Necessary consultancy services such as technical, environmental and others. ● Regulatory consent, project financing.
Converter station	<ul style="list-style-type: none"> ● A common approach is to award a full turnkey EPC contract to a converter station OEM which will encompass all aspects of the converter station design, manufacture, construction and commissioning including: <ul style="list-style-type: none"> – Civil works. – Mechanical and electrical works. – Commissioning and energisation. ● This typically results in a lower risk profile to the client, but potentially at a higher EPC contract price. ● An alternative approach is to divide the works into separate packages and award them individually. Using this approach the client will typically take on a greater risk profile, and is likely to face increased project management costs as a result of co-ordinating the different work packages.
TO project management	<ul style="list-style-type: none"> ● Detailed design management. ● Construction supervision. ● Commissioning. ● Project and contract management. ● System access and energisation.
Contingency	<ul style="list-style-type: none"> ● Contingency based on quantitative and/or qualitative risk register.
Operation and Maintenance	<ul style="list-style-type: none"> ● Day to day operation of the interconnector. ● Routine maintenance activities which may include taking all or part of a converter station out of service either annually or bi-annually. ● In some situations it may be necessary to take fault repairs and downtime into consideration when considering operational costs. An estimate is undertaken in respect of the likely type and quantity of failures which could be expected during the lifetime of the asset, and the likely time and cost to repair them.
Losses	<ul style="list-style-type: none"> ● Losses associated with the operation of the HVDC link must be taken into account in respect of operating costs. For more information refer to Appendix I.
Lifecycle Costs	<ul style="list-style-type: none"> ● In addition to the routine maintenance activities there will be certain other events to be considered during the life of the asset. For HVDC converter stations this may include some or all of the following (this list is not exclusive but provides typical examples): <ul style="list-style-type: none"> – Refurbishment or replacement of control systems and human/machine interface. – Refurbishment or replacement of protection equipment. – Refurbishment of transformers. – Major maintenance on switchgear. – Refurbishment or replacement of ancillary systems such as cooling.

H. Alternative Technologies

This section contains a technical description of some alternative technologies as described in Section 3. The purpose is to introduce the concept of each technology, and discuss some design, construction and operational aspects associated for each, providing some context as to when they may be deployed. For each technology, the following topics are covered:

- Background.
- Technology Description.
- Application of the Technology.

H.1 Series Compensation

H.1.1 Background and Use

To study the power flows on the GB electricity transmission network, the concept of boundaries is used to facilitate network planning. A boundary splits the system into two parts, crossed by critical circuits that carry power between the respective areas and through which power flow limitations may be encountered. Power flows across the system are significantly impacted by changing demand and generation patterns, and network planners aim to predict future changes and the impact they might have on power transfers across network boundaries.

The capability of a boundary becomes constrained if more electricity is planned to cross the boundary than it has capacity to carry (taking into consideration secured contingency events⁴², i.e. power flows after a network fault has occurred or following loss of infeed from a generator). When this risk is identified, it is often necessary to reduce the output of low-cost generators and substitute this with higher cost generators to reduce power transfers across the constrained boundaries. This can increase costs to the Consumer, thus where these additional costs are predicted to increase to significant levels the System Operator must investigate ways of increasing the boundary capacity to a level that facilitates economic and efficient operation of the network.

Thermal constraints (limits imposed by an overhead line or cable reaching its maximum permissible operating temperature) are the most common type and, if not suitably mitigated, these can lead to overloads on the weakest component at the boundary. Constraints may also be imposed by network stability or voltage limits being exceeded following a secured event.

In many cases the construction of additional transmission circuits across a boundary (or upgrading existing circuits) is an effective method of enhancing boundary capacity. However, in some cases, boundary capabilities can be significantly lower than the sum of capacities of the individual circuits crossing that boundary. This is generally a consequence of non-optimal load sharing in which low-capacity circuits reaching their thermal limits whilst high-capacity circuits remain partly loaded. This occurs since the distribution of power flow through a network with multiple paths is determined by the relative impedance⁴³ of those paths, thus power will preferentially flow through the circuits with lower impedance and be diverted away from those with high impedance. However, the impedance of a transmission circuit depends on a number

⁴² Faults that the network is designed to accommodate whilst remaining stable and maintaining quality of supply within defined limits. These secured events are defined in the NETS Security & Quality of Supply Standard.

⁴³ Impedance is a measure of the opposition to alternating current flowing in a circuit and is made up of two components, resistance and reactance.

of factors, including length, such that a short low-capacity route may become overloaded whilst a longer high-capacity circuit is operating at less than its design load.

In cases where the boundary capability is poorly utilised due to non-optimal load sharing it may be possible to modify the line impedance by installing series compensation. Increasing impedance can reduce power flows in a heavily loaded circuit, whilst reducing impedance can divert power flow into a lightly loaded circuit. It can also introduce other benefits such as improved system stability and voltage regulation. This technique has seen widespread use in power systems worldwide for decades. The principle of operation is illustrated in Figure H.1.

Figure H.1: Simplified illustration of how series compensation works

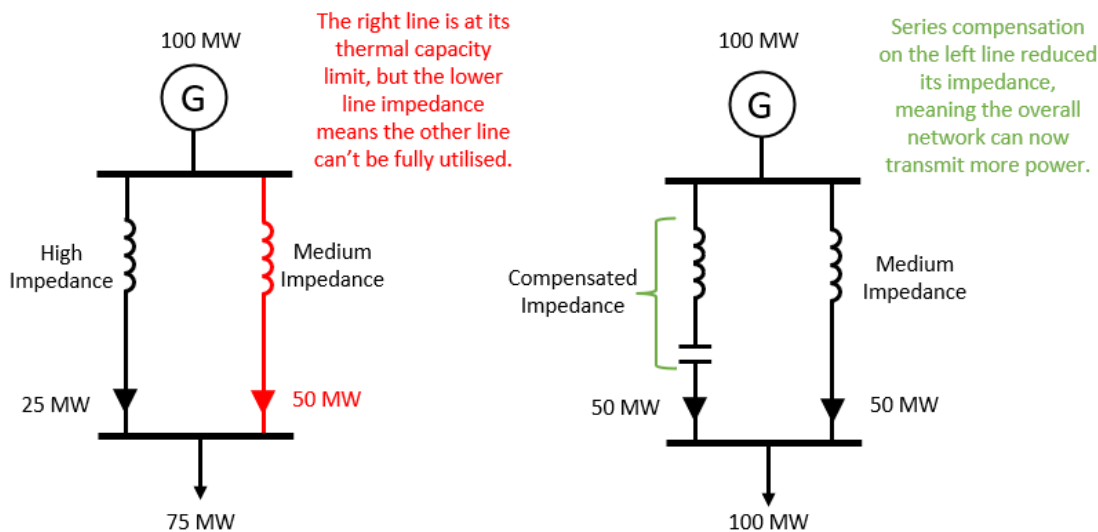

Source: Mott MacDonald

In Figure H.1 both lines have 50 MW capacity, however the lower impedance of the right line constrains the total power delivered. By using series compensation, more power can be delivered to the point of demand.

Series compensation can be used in this way as an effective mechanism for enhancing boundary capacity without installing additional transmission circuits, although such measures are only effective when there is already an imbalance in power flows between local circuits. It cannot inherently create more boundary capacity if all the circuits are already at their respective thermal capacity limits. Thus, it is a highly situational measure and cannot be applied to all areas of the network.

In other cases, boundary transfers can be constrained by stability/voltage performance following a fault, this being a particular issue where circuits are relatively long and have a relatively high 'natural' impedance. In some circumstances this performance can be enhanced by using series compensation to reduce the overall impedance of the transmission circuits crossing the boundary.

H.1.2 Basic Principles of Series Compensation

The basic principle of series compensation is to alter the effective impedance of the line. This is possible because, whilst we cannot decrease the resistance of a line with external devices, reactance can take positive or negative values allowing the overall impedance of the line to be modified (increased or decreased) by external components. Controlling impedance by

adding/subtracting reactance also has the advantage that it generally has a limited impact on network losses (unlike adding resistance, which can result in significant additional power loss).

OHL circuits inherently have a significant positive reactance. Consequently, series compensation can be achieved by inserting additional positive reactance (by putting a reactor in series with the OHL circuit) to increase impedance, or additional negative reactance (by putting a capacitor in series with the OHL circuit) to reduce impedance. Adding reactance by using a reactor has limitations and is not widely used in the GB network, consequently series reactors have not been considered in this report. However, both 'fixed' and 'thyristor controlled' series capacitors have found applications on the long 400 kV circuits that interconnect Scotland and England where the reduction in impedance has allowed stability limits to be relaxed. The following technologies are thus considered in this report:

- Fixed Series Capacitors (FSC).
- Thyristor Controlled Series Capacitors (TCSC).

'Controllable' series compensation is generally adopted to increase or decrease the impedance of specific circuits. These devices operate in a slightly different way from series reactors/capacitors in that they can 'virtually' increase or decrease the circuit impedance by injecting a voltage rather than directly modifying the circuit characteristics. The following commonly used series compensation technologies, which control line impedance by voltage injection, will be covered:

- Static Series Synchronous Compensators (SSSC).
- Quadrature Boosters (QB or quad boosters).

Quad boosters are a technically a subtype of phase shifting transformers (PST), although this distinction is rarely made as they are the predominant type of PST in use on the GB network.

Capacitors and reactors are also installed with a shunt connection to the grid (i.e, they are connected between the HV conductors and earth rather than in series with these conductors); however, their primary purpose is to control the system voltage rather than power flows. Although these devices can have an indirect impact on boundary capability, this is not their primary role, and they will not be considered in this report.

H.1.3 Technology Description - Series Capacitors

H.1.3.1 Fixed Series Capacitors

Fixed series capacitors are well-established, relatively inexpensive, and have been used in transmission networks since the late 1920s. As both the input and output terminals of the capacitor are at line voltage, all the primary components of the FSC (i.e. the capacitors together with their protective devices) have to be insulated from ground. Typically, this is achieved by installing the FSC on an insulated platform, as illustrated in Figure H.2. This would be located in a substation (or other enclosed electrical operating area).

Figure H.2: Fixed series capacitor system (one phase)

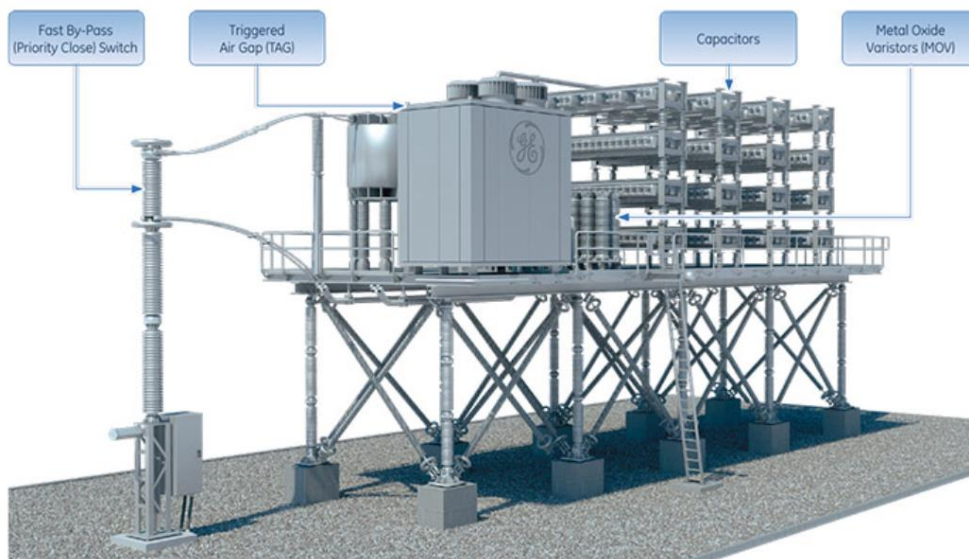

Source: "Series Compensation Systems", GE, 2022. Available: https://www.gegridsolutions.com/powerd/catalog/series_comp.htm

The main advantage of FSCs compared to other series compensation solutions is their relatively low cost and simplicity of design. On the other hand, they offer limited flexibility as the capacitance (which determines the degree of compensation and thus the reduction in line impedance) is fixed, although the system can be bypassed at times the compensation is not required.

FSCs have the potential to introduce a number of technical risks to the transmission system which must be studied and, where necessary, mitigated at the development stage of a project.

FSCs are most effective when utilised to compensate long OHLs and have been applied in GB to overcome stability constraints on the circuits linking Scotland to England. However, there are relatively few OHL circuits in GB where series compensation would provide a worthwhile increase in boundary capability and which are of sufficient length that they would benefit from investment in FSCs.

H.1.3.2 Thyristor Controlled Series Capacitors

A more advanced form of series compensation is the thyristor-controlled series capacitor (TCSC), which has the ability to vary the effective value of the capacitance (i.e. negative impedance) inserted in the OHL circuit. The capacitor section of the TCSC, as with a FSC, provides a fixed level of compensation but an additional reactor is connected in parallel with it. By regulating the magnitude of current flowing in the reactor using power thyristors it can be used to provide a controllable level of cancellation of the capacitor impedance.

The main components of the TCSC are similar to the FSC, and like the FSC are mounted on an insulated platform. However, the thyristor controller adds additional complexity and cost and, together with its associated cooling plant, is a source of operational noise.

In addition to providing a controllable level of compensation the manner in which the impedance of the TCSC is adjusted ensures that low frequency network resonance conditions (such as an interaction with large generating plant known as sub-synchronous resonance) are negatively damped. These resonances are a risk factor when applying FSCs to a power system. However, other technical risks to the transmission network remain.

TCSCs are an established technology and, as with FSCs, they are most effective when applied to long circuits; consequently, there are limited GB applications where these systems would be effective.

H.1.4 Technology Description – Static Series Synchronous Compensators

Static series synchronous compensators (SSSC) are based on a relatively new technology that utilises the latest generation of power electronic converters and 'Voltage Source' operating principles. As outlined above, these systems modify the effective line impedance by injecting a voltage which has the effect of either increasing or decreasing the voltage applied to the line (relative to the actual voltage difference between the circuit ends); thereby increasing or decreasing the power flowing through the line.

Early implementations of SSSCs used large power converters which drew power from the system through one transformer and injected a voltage into the line through a second coupling transformer. These systems were designed to meet the requirements of a particular site, were relatively costly (in comparison with QBs) and had thus found only limited application around the world. There are no systems of this type currently installed in GB and it is considered unlikely that they will offer an economic option for upgrading the NETS. Consequently, these systems have not been considered further in this report.

More recently, focus has shifted to the development and deployment of modular series synchronous compensators, m-SSSC, which offer a number of advantages over the earlier designs. The units are designed to be connected directly at line voltage, thus eliminating the requirement for transformers, and can be built up from standard modules, thus eliminating much of the bespoke design and simplifying reconfiguration/relocation in the event that system requirements change. Also, although the units must be mounted on insulated platforms (similar to an FSC) they occupy a significantly smaller footprint and minimise the requirement to extend an existing substation. As a result, the costs of m-SSSC projects can be much lower than the earlier designs. Projects utilising SSSC at the transmission system level are now predominately this modular type, with installations in the Republic of Ireland, USA, Greece, and most recently in 2021, the United Kingdom.

As they do not directly change the impedance of a circuit, SSSCs have fewer negative technical impacts on the transmission system than series capacitors/reactors. Furthermore, as they can be programmed to respond rapidly to disturbances on the transmission system, they can be used to increase the stability and resilience of the network.

Due to their relatively low costs, it is anticipated that in future m-SSSCs will find further applications on the GB transmission system where boundary capability is limited by unbalanced circuit loading. However, the technology is still to be fully demonstrated long-term in an operational environment and is thus not fully established. Also, the technology has been developed by one supplier and is thus only currently available from a single source. Figure H.3 shows an installation by Smart Wires at NGET's Penwortham substation.

Figure H.3: SSSC Installation by Smart Wires at NGET's Penwortham substation



Source: Image courtesy of Smart Wires

H.1.5 Technology Description – Quadrature Boosters

Quadrature Boosters, a type of phase shifting transformer, have been installed on the GB transmission system since the 1960s. As with the SSSC, they change the effective impedance of a line by injecting a voltage to increase ('boost') or decrease ('buck') the actual voltage difference between the ends of a line.

A QB is in essence two transformers, one drawing power from the line and the second coupling unit injecting a series voltage into the line. By providing multiple 'tappings' from the winding of the first transformer, a mechanical switching device called a tap changer can be used to vary the injected voltage and whether it is added or subtracted from the system voltage; thus varying the effective impedance of the line.

Whilst costly, QBs represent a well-established technology that has been successfully applied to the GB transmission network and has a good operational record. Furthermore, since it is based on transformer technology, the maintenance requirements are well understood, and the necessary skills are readily available. However, whilst QBs do allow for control of the line impedance, the rate of change is relatively slow (in comparison with a SSSC), meaning that they are not able to respond immediately to transient network events.

Whilst QBs are typically installed in existing substations, it is often necessary to extend the operational area to accommodate them and they do contribute to noise pollution. Figure H.4 shows an example of a QB supplied by GE Grid Solutions and installed at NGET's High Marnham substation.

Figure H.4: Example of a quadrature booster at NGET’s High Marnham substation



Source: Image courtesy of GE Grid Solutions, “PTR-0189 Power Transformers and Reactors Brochure”, GE, Jun. 2019. Available: https://www.gegridsolutions.com/products/brochures/Power_Transformers/Power_Transformer_Range-Brochure-EN-2019-06-Grid-PTR-0189.pdf

H.1.6 Series Compensation Technology Comparison and Application

Something that must be understood with series compensation is that it does not reduce the line losses, and may increase these losses by increasing power flows through a high impedance circuit. This is because the compensation does not affect the inherent resistance of the circuit, a characteristic which along with the magnitude of the current flowing in the circuit determines the conductor losses. Furthermore, there are additional losses associated with the series compensation equipment (for example, QBs exhibit similar losses to conventional transformers). However, losses can be reduced by minimising the level of compensation provided when not required or switching out the compensation system to eliminate its loss contribution.

A summary comparison between the various series compensation technologies is shown in Table H.1.

Table H.1: Application comparison of series compensation technologies and quad boosters

Device Type:	FSC	TCSC	m-SSSC	QB
Increase in power transmission capacity	Y	Y	Y	Y
Variable level of power flow control	N	Y	Y	Y
Fast response to dynamic network events	N	Y	Y	N
Footprint Area	Medium	Large	Medium	Large
Environmental concerns	Landscape	Landscape, noise	Landscape	Landscape, noise, oil leakage
Technology readiness	9	9	7-9 (>110 kV)	9

H.2 Superconductors

H.2.1 Background

Superconducting cables are a technology that has been discussed for transmission system integration for over five decades. However, it has only been in recent years that commercial small-scale implementation has been achieved.

Superconducting materials have a very low resistance in comparison with conventional conductors, consequently they can carry many times the current density (i.e. the electrical current per unit of conductor cross-sectional area) of conventional conductor materials. However, they must be cooled to extremely low temperatures before exhibiting their unique properties. Early superconductors required a critical temperature close to absolute zero (-273 °C) in order to achieve their low resistance properties, however later developments have led to materials which exhibit the phenomenon at temperatures of around -180 °C to -200 °C. These materials are classified as High Temperature Superconductors (HTS), which are defined as having a critical temperature of activation not less than -196 °C (77 °C above absolute zero), and commercial applications of superconducting cables have been based on these.

Given the very low temperatures that are required by superconductors, additional hardware is required in superconducting cables in order to keep the superconductor in the required temperature range. This is usually achieved by submerging the superconductor in a very low temperature cryogenic fluid, such as helium or liquid nitrogen. This presents challenges of containing the cryogenic fluid around the superconducting cables while preventing the fluid from being heated by the local environment and cooling the fluid if it does heat up. The first challenge is typically addressed by placing the superconducting cable in a cryostat, which is a multi-layered pipe that provides sufficient thermal insulation to drastically reduce the rate at which the cryogenic fluid heats up. This requires at least one of the layers in the cable build to be a high-performance thermal insulator (such as a vacuum). The second challenge can be addressed by replacing the fluid (i.e. using a constant cryogen supply), or by re-cooling the cryogen using advanced refrigeration systems called cryocoolers.

The cooling requirements of HTS materials can be maintained using liquid nitrogen-based cooling systems similar to those employed for transportation of liquified natural gas (LNG), thus making practical implementation more achievable.

As the conductors are surrounded by coolant the small electrical losses are dissipated through the refrigeration system (rather than direct to the environment, as is the case with conventional cables), thus there is no requirement to maintain thermal separation between individual cables, allowing them to be laid at much closer spacing than would generally be required for high-power circuits and minimising the required installation corridor. However, the challenge of keeping the system cooled to its critical temperature, and the relative cost of manufacturing the superconducting material are the primary hurdles to wider adoption of the technology in transmission systems. This is reflected in their relative lack of market penetration, with only approximately 30 such projects worldwide. There are currently no projects constructed or planned in GB.

There has recently been progression with a low-temperature superconductor magnesium diboride (MgB_2) which has a critical temperature of -235 °C . Its relative ease of manufacture compared with HTS materials potentially outweighs the additional costs of the cooling infrastructure, since helium gas (rather than nitrogen) must be used to achieve the required temperature. Currently MgB_2 systems are at the demonstration level, with no commercial projects announced at the time of writing, and thus are not considered further as part of this study.

H.2.2 Technology Description

H.2.2.1 Components and Material Composition

Superconducting cable has several physical characteristics which are comparable to conventional cable, including:

- Cable can be direct buried or placed in ducts.
- Cable jointing (splicing) to create long lengths is possible on site.
- Comparable bending radius and pulling strengths.
- Can be laid in a conventional manner using spooled drums.
- Cable delivery lengths are typically up to 500-700 m, limited by the drum size and not the cable design.

However, there are several key differences.

- The most critical is the cryogenic (very low temperature) system required to cool the superconductor. A feed line pumps coolant through the cable, this fluid typically being liquid nitrogen for HTS, which is circulated through a closed-loop system from a cooling station. There are different cable topologies for achieving this, but usually the centre of the cable forms the inlet line to ensure maximum cooling of the superconductor with a circumferential return path outside the insulation package.
- The conductor is a composite of commercially available stranded HTS tapes (that are also used in other applications, such as for high power magnets) carried on a conductive former.
- The conductors are insulated using a paper-polypropylene laminate (PPL) insulation package formed by wrapping multiple layers of tapes. In service this package is immersed in liquid nitrogen, which fills the voids in the package in the same way as oil is used in a conventional paper insulated cable.
- The cable is enclosed in a vacuum tube to minimise heat entering the cable from the environment and thus minimising the cost of providing and operating the cooling system.

Currently to achieve voltages greater than 110 kV, each phase must be housed in a separate cable. However, for lower voltages all three phases can be contained within the same outer cable sheath as a three-core or concentric arrangement.

An example of a typical single core HTS cable is illustrated in Figure H.5.

Figure H.5: Typical HTS cable

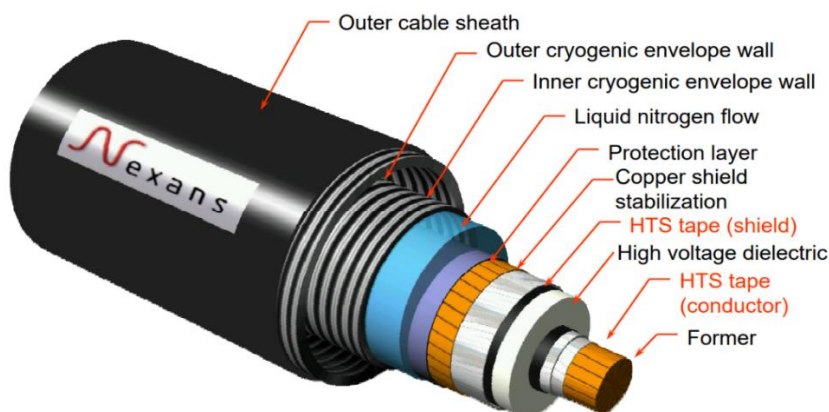

Source: Image courtesy of Nexans.

The cooling system uses a standard set of components, typically consisting of a fluid reservoir, control unit, heat exchangers, and a series of pipes, valves, and pumps to circulate the coolant fluid through the system, as shown in Figure H.6.

Figure H.6: Basic components for a typical superconducting coolant system

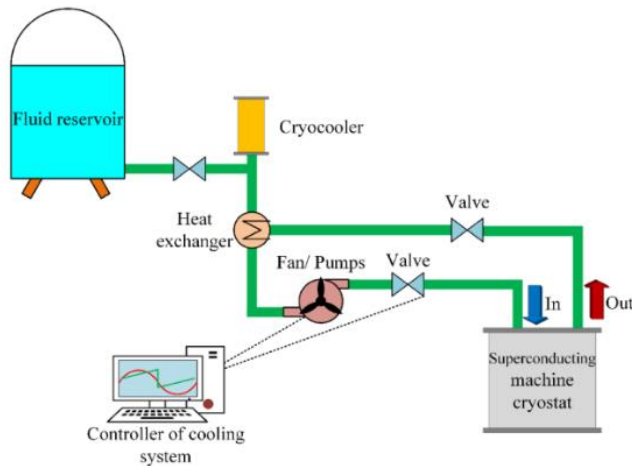

Source: Mohammad Yazdani-Asrami, Alireza Sadeghi, Milind D. Atrey, "Selecting a cryogenic cooling system for superconducting machines: General considerations for electric machine designers and engineers" International Journal of Refrigeration, Volume 140, 2022, Pages 70-81, ISSN 0140-7007, <https://doi.org/10.1016/j.ijrefrig.2022.05.003>.

H.2.3 Applications

At present no projects have been installed for operation at a voltage of 400 kV a.c., with 138 kV being the highest voltage rating in commercial service, although it is understood that there are no technical barriers to developing superconducting cables for higher voltages and industry development programmes have manufactured higher voltage systems and tested them under simulated operational conditions. Similarly, prototype superconducting HVDC cables have been developed and tested (including a European funded demonstration of a 320 kV d.c. MgB₂ cable). However, the practical application of superconducting cables at transmission voltages has yet to be fully demonstrated and additional development is expected to be required to achieve wider commercialisation of the technology.

The key benefits of superconducting cables are their ability to carry higher currents using a single conductor, and their thermal independence from other cables (which avoids the need for physical separation for thermal reasons, although maintainability must still be considered). This higher current capacity thus allows these systems to achieve similar power ratings to conventional conductors while operating at a lower voltage. Hence, whilst HTS technology is still relatively immature and costs are high, there are niche applications where it can represent an economically viable solution to enhancing transmission system capability. This is particularly the case in dense urban environments where a conventional cable installation could otherwise face extensive civil works, the requirement for which can be mitigated by the superconducting cable's relatively small installation corridor. Further, the ability to deliver high current (and thus power) at lower voltages allows new interconnections to be established within distribution networks, which can permit sharing of spare/contingency capacity allowing a reduction of required network components. For example, where due to a requirement to transmit a large quantity of power between areas of a distribution network a standard solution may be to step up to a transmission voltage of 275 kV or 400 kV and then back down to distribution level, it may be possible to use a superconducting cable instead. This can avoid the installation of additional transformers and switchgear and remove the associated need to acquire sufficient land to construct or extend substations.

A 2016 study undertaken by WPD⁴⁴ examined the feasibility of HTS cable replacing conventional systems. Their findings concluded that while HTS cable was not viable at replacing a typical 11 kV or 33 kV system, for greater voltages where a greater footprint is required, it could be considered as a viable option as HTS prices decrease in the future. When not considering civil works, land and right-of-way, high-voltage equipment, and substation costs, HTS cable was found to be approximately 5-6 times more expensive. However, a HTS solution took up between 18-23 times less land area, potentially being the only economically viable solution where the footprint is constrained.

At HVAC transmission voltage levels (400/275 kV a.c.) the introduction of high-temperature low-sag conductors has allowed the post-fault current carrying capability of ‘standard’ OHL circuits to exceed 5,000 A, which presents difficulties where sections need to be undergrounded. Conventional cables are typically limited to around 2,000 A per cable, such that cable systems comprising three conductors per phase (i.e. six three-phase groups to replace a double circuit line) are under consideration. There is thus the potential to replace 6x3 conventional cables, which need to be widely spaced to minimise thermal interaction, with 2x3 superconducting cables with separation constrained only by maintainability (i.e. the ability to repair one circuit whilst the other remains in service). It should be stressed that, at the time of writing, the technology readiness of such a solution is not sufficient to support its widespread adoption for critical transmission infrastructure. However, if the costs of HTS tapes continue to fall and manufacturing capacity grows then it is possible that HVAC superconducting cable systems may present a practical solution for undergrounding 400 kV circuits in the next decade.

The case for high-current HVDC cables is less clear, since to date the current carrying capacity of cabled HVDC systems has been limited by the capacity of the power electronic valves⁴⁵ as well as the cables. However, higher capacity valves are now becoming available, and it is possible that in future potential power ratings will require the use of groups of conventional cables. If this proves to be the case, then high current superconducting cables may become viable for HVDC transmission.

Table H.2 gives examples of some commercial transmission/distribution projects which have been implemented.

Table H.2: Summary of several commercial HTS cable projects

Project Name/Location	Year	Power Rating	Voltage	Length	Description
LIPA1 Project - Long Island, USA	2008-2012	574 MVA	138 kV a.c.	600 m	Established the feasibility of HTS cable in a transmission grid for the first time, showcasing the ability of delivering more power within a reduced area. ⁴⁶
AmpaCity Project - Essen, Germany	2014-2021	40 MVA	10 kV a.c.	1 km	Reported to be a commercial success due to HTS cable’s small footprint reducing the extremely high costs associated with civil works in the dense city centre, operational for 7 years. ⁴⁶
Shingal Project – Shingal, South Korea	2019-ongoing	50 MVA	23 kV a.c.	1 km	A HTS system connected two substations, thus sharing the anticipated additional load and avoiding the costly installation of a 60- MVA transformer. ⁴⁷

⁴⁴ “Superconducting Cables – Network Feasibility Study,” Western Power Distribution, 2016. [Online]. Available: https://smarter.energynetworks.org/projects/nia_wpd_015/

⁴⁵ IGBT transistors, used in Voltage Source Converters, have generally been limited to circa 1,500 A. Higher current devices are now available, and it is anticipated that capability will increase over time.

⁴⁶ “NEXANS SUPERCONDUCTORS FOR ELECTRICITY GRIDS - WHITE PAPER 2022,” Nexans, 2022

⁴⁷ “Korea’s KEPCO Commercializes Superconducting Transmission Solution”, Utility Products, Nov. 09, 2021. [Online]. Available: <https://www.utilityproducts.com/transmission-distribution/article/14211957/koreas-kepc-commercializes-superconducting-transmission-solution>

Project Name/Location	Year	Power Rating	Voltage	Length	Description
Resilient Electric Grid - Chicago, USA	2021-ongoing	62 MVA	12 kV a.c.	200 m	The project linked together isolated substations in the densely populated Chicago, lowering excess capacity and increasing security of supply. ⁴⁶
Shanghai HTS Project - Shanghai, China	2021-ongoing	77 MVA	35 kV a.c.	1.2 km	This installation had a single three-core HTS cable replace four parallel 220 kV XLPE cables located in the Xuhui district at the heart of Shanghai. ⁴⁸
Superlink Project - Munich, Germany	Projected 2025	500 MVA	110 kV a.c.	12 km	Superlink explores using a 12 km long HTS cable to connect the load centre at the South of Munich to the main transmission feed located to the North. ⁴⁹

In addition to the projects which have been implemented there is also ongoing research and development activity. At present, grid demonstration installations are being tested which go up to 320 kV d.c., however it is still too immature for commercial applications. There has also been exploration of using HTS cable for offshore grid applications, with the primary savings derived from the reduced equipment required for the collector station platform. However, these marine superconductors are still at the initial research stages, being at TRL 2 and currently no commercial installations are in the pipeline for at least five to eight years, and hence further details are not available in this regard for inclusion within this report.

H.2.4 Principal Cost Components

Further information in respect of costs is provided in Section 4 of this report. However, information in respect of typical cost components as received from suppliers is provided below. An approximate distribution of cost for a typical HTS cable can be seen in Figure H.7, with data supplied by Nexans, one of the leading HTS cable manufacturers.

Figure H.7: Typical HTS cable cost breakdown

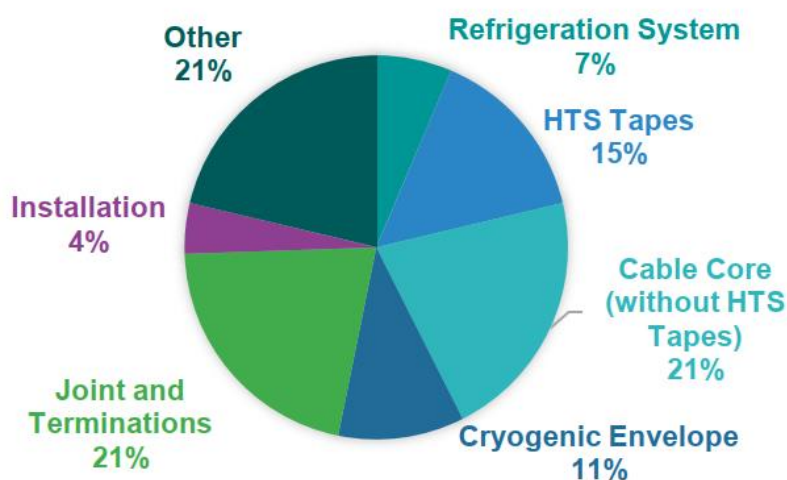

Source: Supplied by Nexans

The common theme of HTS cable is that the installation costs can be substantially cheaper than a conventional cable (refer to Section 4.3), but at a higher CAPEX introduced from the

⁴⁸ Xi Hua Zong, Yun Wu Han, Chong Qi Huang, "Introduction of 35-kV kilometer-scale high-temperature superconducting cable demonstration project in Shanghai, Superconductivity", Volume 2, 2022, 100008, ISSN 2772 8307, <https://doi.org/10.1016/j.supcon.2022.100008>.

⁴⁹ "The Munich SuperLink project," TRANSFORMERS MAGAZINE | Special Edition: Superconductivity, pp. 10–15, Aug. 2021.

superconductor tapes, cryogenic system, and more sophisticated terminations. Thus, these systems are cost effective specifically where planning and civil works are predominant factors.

However, it is crucial to state that these systems are still in a relatively extremely early phase of development. Many of the dependent material and subsystem industries have high margins of uncertainty, and as such these figures should not be strongly compared to more established technologies as absolute.

H.2.5 Advantages and Disadvantages

In summary, there are several advantages to HTS which have been the driver for their continued research, including:

- **Smaller installation corridor:** the installation corridor for a superconducting cable system can be significantly smaller than a conventional cable system carrying the same current as the cables do not need to be spaced for thermal independence. Thus, these cables take up less space in the ground as compared to conventional cables. In some situations, superconductors could therefore result in lower CAPEX, making them economically viable.
- **Lower power losses:** as the resistivity of a superconductor is extremely low, there are effectively no resistance-based power losses across the line. However, there are still losses associated with the cryogenic cooling system that need to be considered, outside of the power required to operate the system itself. These sources include thermal leakage through the insulation, hydraulic and pumping losses, plus losses at the joints and terminations.
- **Reduced investment in other plant:** for the same power transfer capacity, the operating voltage of a HTS cable system can be lower than a conventional one (due to the higher current carrying capacity). Hence it may be possible to reduce transformer capacity and the requirement for high voltage switchgear to achieve the desired level of redundancy in a transmission or distribution system. This would complement its application in dense urban spaces.
- **Automatic fault quenching:** HTS cables have a maximum current threshold, the critical current, which generates sufficient resistive losses that the material temperature increases, and it becomes highly resistive. In the case of a fault, in several milliseconds this automatic increase in resistance limits the fault current, thus giving the cable automatic current limiting capabilities. This can be a significant benefit when installing additional interconnections at distribution voltage.

However, these would need to be evaluated in conjunction with some disadvantages which include:

- **Poor cost effectiveness outside of specific constrained environments:** HTS cable is significantly higher cost than conventional cable when civil works are not a major factor. Costs for HTS tape at present are estimated at several hundred £/kA.m (i.e. cost per kiloampere-metres)⁵⁰, with conventional conductors being a fraction of this cost. However, if there are footprint restrictions, such as in a heavily populated area with little space, HTS can become cost-effective.
- **Long fault recovery time:** during a fault, the HTS can heat up above its critical temperature with a resulting loss in conductivity. Depending on the cooling method, several seconds to minutes may be needed for the material to be cooled to the superconducting state again, meaning potentially longer fault restoration times as compared to conventional cables. Additionally, predicting this recovery time can be a difficult process due to the complex design of the cable.

⁵⁰ Doukas, Dimitrios. (2019). Superconducting Transmission Systems: Review, Classification and Technology Readiness Assessment. IEEE Transactions on Applied Superconductivity. 29. 10.1109/TASC.2019.2895395.

- Introduced power system protection difficulties: the aforementioned variable resistance with fault current introduces challenges from a power system protection standpoint, as it makes short-circuit levels in the connected system more difficult to calculate and it is more difficult to distinguish between load currents and fault currents.
- Unknown long-term reliability: as these systems are relatively immature, long-term performance data is unavailable. This is reflected in their technology readiness level, with a.c. HTSs at TRL 7, whereas d.c. HTSs have a TRL of only 5.
- Inconsistent product standardisation: as the field is so novel, there is a great degree of change in the materials, design, and manufacturing, resulting in differing performance characteristics between projects.

H.3 Gas-insulated Line and Pressurised Air Cables

H.3.1 Introduction

Gas-insulated Line (GIL) systems can be used in selected applications to transmit electricity as a viable alternative to overhead lines and underground cable, taking aspects from both technologies. GIL is well-established, being in use since the early 1970s. In terms of transmission capacity, GIL is approximately the same as OHL and around double that of a XLPE cable system. Installations can be operated up to extremely high voltages, typically between 245 kV up to 1,000 kV. It sees primary use in substations, power stations and other areas where there is a requirement to transmit high power levels (meaning that cable systems would not be economic) but where there are physical space constraints restricting the use of air insulated equipment. These tend to be short route lengths, typically approximately 200-300 m per pipe in GB for 400 kV installations. However, there are some installations that are far longer, such as the 275 kV 3.3 km Shinmeika-Tokai line in Japan⁵¹ and the recent construction of the 1,000 kV, 5.4 km installation across the Yangtze river in China⁵². Examples could include the connection of a HVDC system to a neighbouring transmission substation, the connection of a thermal generator to its step-up transformer, or to facilitate a connection between an overhead line and a GIS switchboard.

More recently, as a result of concerns regarding the use of the gas used for insulation, we have seen developments in the area of pressurised air cables which are similar in appearance to GIL, but do not require the use of greenhouse gasses. This is still a technology which is under development with initial pilot demonstrations having taken place, but no commercial application at the time of writing.

H.3.2 Gas-insulated Line

H.3.2.1 Technology Description

GIL has the exterior appearance of an aluminium pipe, typically of a diameter of 50-60 cm wide for HV systems. Inside, there is a central, hollow conductor also made of aluminium, supported in place by cast resin epoxy support struts. Surrounding this conductor is a pressured insulating gas. A cross section illustrating this is shown in Figure H.8. These GIL sections are usually 15-20 m long, with sections locked together via flanged connections, which are either bolted or welded on site. Each of these sections carries a single phase, thus requiring three pipes to form

⁵¹ N. Takinami, S. Kobayashi and A. Miyazaki, "Application of the world's longest gas-insulated transmission line in Japan," *Proceedings of the 7th International Conference on Properties and Applications of Dielectric Materials (Cat. No.03CH37417)*

⁵² "ABB Power Grids commissions world's first transmission line under the Yangtze river," ABB, May 04, 2020. [Online]. Available: <https://new.abb.com/news/detail/61647/abb-power-grids-commissions-worlds-first-transmission-line-under-the-yangtze-river>

a three-phase system. Due to low external thermal and electromagnetic constraints however, each pipe can be installed with relatively little clearance from each other, sometimes as low as 20-30 cm spacing.

Figure H.8: Cross section of a standard GIL, Siemens

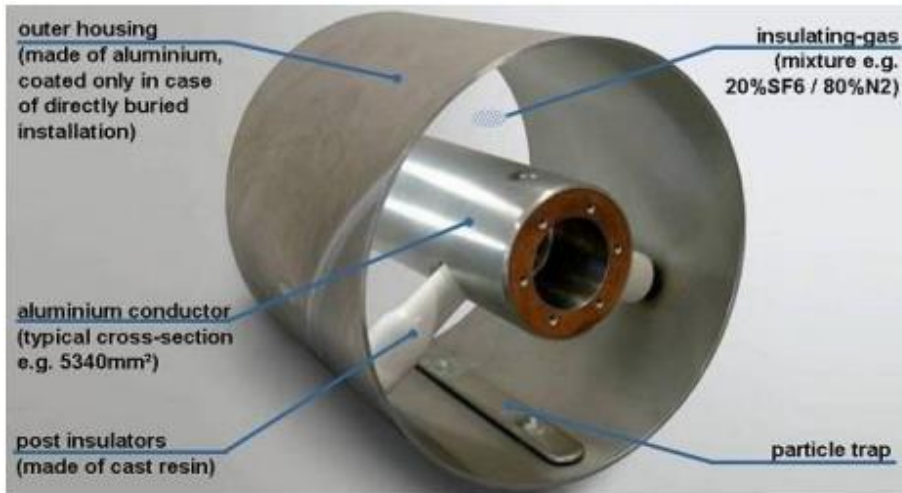

Source: “Electricity Transmission Costing Study: An Independent Report Endorsed by the Institution of Engineering & Technology,” Parsons Brinckerhoff, Jan. 2012. Available: <https://www.theiet.org/impact-society/factfiles/energy-factfiles/energy-generation-and-policy/electricity-transmission-costing/>

Outside of the housing and conductor, another major material component of GIL is the insulating gas. Historically, this has been sulphur hexafluoride, i.e., SF₆. Whilst this gas has fantastic insulation properties that suit well as a dielectric medium, it is also the most potent greenhouse gas currently known, being 22,800 times more effective than CO₂ at trapping infrared radiation in the atmosphere. For more information on emissions, please refer to Appendix K. Older installations pre-millennium used a composition of 100% SF₆, although due to the high global warming potential, other mixtures have been explored since. Over the past two decades the insulating gas mixture usually has been composed of 80% N₂ and 20% SF₆, typically pressurised to 5-7 bar. However, in recent years there has been significant development of SF₆ free systems, with various gas mixtures being tested, such as a more highly pressured mix of nitrogen and oxygen for example. Implementation of these novel insulating gasses is not fully realised yet, with current estimated TRL of 7 and full maturity expected by 2030.

H.3.2.2 Manufacture, Installation, and Maintenance

Due to the relatively simple component materials, fully assembled GIL sections can either be delivered directly to the site, or alternatively one can deliver the components to the installation site for fabrication and assembly. The former option would be constrained by the pipe length for road access, whereas the latter requires a suitably clean, large environment for assembly to take place. To ensure no contamination of the pipe interior, each piece has its ends capped prior to installation.

Sections are then secured together with end-piece flanges, and bolted together or welded using automated equipment. Weld quality is thoroughly examined using x-ray or ultrasonic tests. GIL pipe sections have a limited bending radius, approximately 400 m, although joint elbow pieces with a variable angle can be installed as required. The system is therefore rigid and cannot easily be adapted in the event of on-site changes – the lengths and angle pieces are usually determined at design stage and, in the event that a change to the route is required, then this could introduce a significant delay due to having to manufacture additional components. Having

said that, angle pieces of up to 90 degrees are available, and thus routing constraints such as tight bend radii (which could pose a problem for cable circuits) can be negotiated as long as these are fully considered at detailed design stage and prior to commencement of manufacture.

Where GIL particularly excels in is the number of options available for installation. It can be mounted at ground level, set high in the air with support struts, directly buried, or tunnel installed. Due to the ease of access to the public, above ground installations are usually contained within the secured compound of the power station or substation, as shown in Figure H.9. While direct buried is an option, requiring an anti-corrosion protective layer, it is increasingly rare due to the difficulty of access. Tunnel instalment also has different options available. For densely populated areas, a bored tunnel installation is preferred to reduce risks of pre-existing infrastructure cross-over. For rural or suburban regions, large surface tunnels are also an option, helping to get immediate access to the lines for maintenance as required, as shown in Figure H.10. As indicated, this requires substantial physical infrastructure to achieve.

Figure H.9: SF₆-free GIL installation at a National Grid substation



Source: "National Grid Energizes World's First SF6-free 420 kV Gas-insulated Line," GE Grid Solutions, Apr. 2017. Available: <https://www.gegridsolutions.com/press/gepress/g3-announcement.htm>

Figure H.10: 1,000 kV GIL double circuit tunnel installation



Source: "Gas-insulated transmission line (GIL)," Hitachi Energy. 2023. Available: <https://www.hitachienergy.com/products-and-solutions/high-voltage-switchgear-and-breakers/gas-insulated-transmission-line>

Despite the pipes being tightly packed together, during service only the specific line being checked needs to be switched off, due to the low thermal and electromagnetic emissions from the live lines, although in practice in a three-phase system all three lines would be de-energised. Aspects for inspection include current tube pressure and water infiltration, and recalibration of pressure, SF₆, and oxygen monitors.

In the event a pipe section would need to be replaced, the process is relatively quick and simple. First the insulation gas would be extracted, the broken section cut out and replaced, followed by gas re-filling and testing. This process takes approximately 2 weeks.

However, consideration must also be given to the practical constraints associated with using SF₆ and working on pressurised systems. Suitably competent personnel are required, particularly for the de-gassing and re-gassing process, and specialist equipment such as gas processing plant and storage tanks is also necessary. If this equipment is owned by the TO then it must be maintained, with relevant test certificates kept in date. Further, in the event that such equipment is “shared” across various assets then it may not be immediately available at the required location, introducing delays to certain activities such as fault repairs. Further, these systems are pressurised and are usually divided into different “gas zones”. In order to work on part of the system it is usually necessary to either totally depressurise adjacent gas zones or at least reduce their pressure, so as to minimise any risk to operatives. These areas must all be considered as part of both construction programmes and O&M requirements, ensuring that relevant plant and resources are available as required.

Due to the concerns around SF₆ and limitations imposed by the rigidity of the system, there has been a drive to research new structural and material designs. Presently, there is much attention on methods replacing SF₆ with a highly pressured oxygen mix, as shown in the following Section H.3.3. However, more air at greater pressure is required to replicate the same insulation properties of SF₆, thus necessitating a larger pipe housing. However, the maximum overall diameter of the GIL pipe is set by the connecting flanges at the end of each pipe, it being wider than the outer housing due to the space needed for bolting section together. With novel techniques to connect pipe sections together, these flanges can be made smaller, and thus the overall diameter of these SF₆-free designs can be comparable to the sizes of traditional GIL pipes. Some manufacturers such as Hitachi have also developed a fluoronitrile based gas mixture which can be directly substituted in existing 420 kV GIL systems for SF₆, resulting in a global warming potential reduction by 98.8%⁵³.

Other areas of research also include new methods of installation and more flexible components.

H.3.2.3 Cost Breakdown and Losses

GIL systems have the following approximate cost breakdown:

- Materials 40%: aluminium is the largest material cost as part of this, being the primary material of the conductor and outer housing.
- Installation process 40%: the onsite installation process incurs significant costs, where the more bends in the route, the greater associated time delays.
- Other 20%: encompasses planning, permission, and design works.
- From a pricing sensitivity perspective, GIL is highly variable due to the number of installation options available and particularly for underground works, the unique routing challenges required for each site. When considering tunnel installations, benefits provided include

⁵³ “EconIQ™ retrofit for gas-insulated lines ELK-3, 420 kV”, Hitachi Energy, 2022. Available: <https://www.hitachienergy.com/uk-ie/en/products-and-solutions/high-voltage-switchgear-and-breakers/econiq-eco-efficient-hv-portfolio/econiq-retrofill-gil-elk-3-420kv>]

significantly reduced maintenance costs and reduced disruption of surface-based infrastructure. However, this would come with extended civil costs, and the associated O&M requirements. Works considered would be constructing the concrete lined tunnel, ventilation shafts and emergency egress, vertical end-shafts, and the headhouse above these shafts for site security and storage of ventilation plant. Additionally, there are also preliminary design costs to consider. These would include ground and site investigations examining tunnelling methodology and risks, ventilation studies for safety of personnel, and environmental studies observing impacts on noise, traffic, spoil removal, and wildlife. Tunnels are discussed in greater detail in Appendix F.

- Compared to OHL and UGC, the conductor losses on GIL are lower due to the larger inner conductor cross-sectional area. With these systems having capacitances comparable to OHL, unlike UGC, reactive compensation, and the associated losses, does not generally need to be considered for GIL.

H.3.2.4 Advantages and Disadvantages

In summary, GIL systems have several advantages for transmission systems, including:

- Variety of installation options: UGC needs to be installed below ground at a certain depth and is limited by bending radius, while OHL requires a set ground clearance. GIL however has multiple routing options to suit the environment, and requires significantly less space than the air insulated equivalent.
- Equal or greater transmission capacity: at EHV voltages, GIL systems have approximately equal capacity to OHL, and double the capacity of XLPE insulated UGC.
- Self-healing insulation: if a flashover event occurs, i.e. a sudden large discharge of electricity flows through the insulation, usually due to a sudden high current induced by a short circuit, the insulation material may be damaged. For GIL, as the insulation material is an inert gas mixture, it will immediately self-heal.
- Less reactive power compensation infrastructure required: GIL has a capacitance four to five times less than UGC, thus needing less additional infrastructure in comparison.
- Vertical installation: GIL can be installed on large inclines, for example, within hydro power stations. However, this application has since been superseded due to advancements in cable design.

There are disadvantages associated with GIL however, hence having a significantly smaller presence on the GB network compared to other solutions:

- Not cost-effective for long lengths: virtually all implementations so far have been at installations that have had routing constraints that limited the viability of other options. This can be partly attributed to the high CAPEX of tube connections, requiring casting, welding, and rigorous bolting for every 15-20 m of pipe section.
- Reduced repair ability: these systems have limited options for repair. This often requires the entire pipe section to be removed, increasing costs.
- Presence of SF₆: currently the vast majority of GIL use SF₆ as an insulating material. While leakage of this gas is rare, the extremely high global warming potential is problematic.
- Installation and Maintenance requirements: specialist gas handling and storage equipment is required for both the construction, and in the event of any intrusive maintenance. Personnel with gas handling qualifications are also required, and it can be necessary to de-gas adjacent gas zones to carry out work.

H.3.3 Pressurised Air Cables

H.3.3.1 Technology Description

Eliminating the use of SF₆ in GIL systems has been a top priority. One such solution is Pressurised Air Cable, PAC. By using an outer housing with a larger diameter than GIL, similar dielectric performance to conventional SF₆ can be achieved by using a mixture of more highly pressurised air.

One of the key design considerations for PAC is the flange design. By using a machined, double sealing, system, the flange diameter can be made considerably smaller, making the overall diameter of the PAC comparable to GIL despite the larger outer housing due to the latter requiring a considerably wider flange for bolting and welding sections together. Due to the similar properties and dimensions, like GIL, PAC also has multiple installation options, including troughs, tunnels, and pipes. A sample of a PAC system is shown in Figure H.11.

Figure H.11: An example of a pressurised air cable, with slimmer flange design, Hivoduct



Source: "Hivoduct Pressurized Air Cable Technology," Hivoduct, 2021. Available: <https://www.hivoduct.com/Technology/>

The primary reason why this technology is distinguished from other GIL systems as pressurised air cables is due to the flexibility introduced by the flange, allowing a range of $\pm 10^\circ$ between two pipe length sections where otherwise traditional systems would need a separate fixed-angle connector.

Currently there are only pilot installations in operation, such as the Druckluftkabel Swiss railway system project, operating at 145 kV, 2,500 A. In the following years, installations with greater voltages up to 420 kV are in the pipeline, with approximate capacity of 3,600 MW.

H.3.3.2 Cost Breakdown and Losses

At the time of writing, as PAC is still an immature technology, precise costing data is unavailable. However, the following observations can be made. PAC shares many of the same costing sensitivities as GIL, such as being highly sensitive to site requirements and primarily made from aluminium. Differences include the joint design introduced opportunities for cheaper onsite construction and repair works, along with avoiding the material purchase of SF₆ and leakage monitoring equipment.

Like GIL, losses would be primarily introduced in the form of conductor losses, although losses associated with the air pressurisation system would also need to be accounted for.

H.3.3.3 Advantages and Disadvantages

PAC includes many of the same characteristics as GIL. Some additional advantages PAC offers include:

- Elimination of SF₆: highly pressurised air with zero GWP can be substituted, offering both immediate environmental benefits and reduction in gas monitoring requirements.
- More Flexible Bending Radius: due to the flange design, more routing opportunities are available while also offering fewer angle joint pieces. This introduces other benefits as having fewer joints means less expensive construction and repair, and less susceptibility of gas leakage.
- It also shares disadvantages with GIL, however extra considerations are:
- Unproven technology: PAC is still at a relatively immature phase of development. At present there are no 400 kV system pilot projects or lower voltage grid installations operational.
- Greater Gas Pressurisation: the air mixture is pressurised to approximately double SF₆, thus incurring extra costs to maintain this additional pressure.

I. Losses

I.1 Introduction

In analysing the lifetime costs of electricity transmission assets, losses in the systems and the associated costs must be considered. These can be generated from a number of sources, but generally the main component is from resistive losses. All conductors have an inherent electrical resistance, which is dependent on the material and the cross-sectional area (csa) of the conductor. When current is passed through a resistance then heat is generated, which increases as the resistance and/or current increases, meaning the amount of power received at the end of an electrical circuit is less than the amount injected at the source. In the case of electrical transmission systems, this heat generation is unwanted and cannot practically be utilised and is therefore characterised as a loss. These resistive losses are generally dominant in respect of calculating overall losses in a transmission system and the quantity of heat lost is proportional to the square of the current⁵⁴. However, in some cases other sources of losses may also need to be considered.

A high-level description of different sources of losses for three commonly used electricity transmission technologies is provided in Table I.1 below:

Table I.1: Typical sources of losses

HVAC Overhead Line	HVAC Underground Cable	HVDC System
<ul style="list-style-type: none"> Resistive (ohmic) losses are the main losses that occur in OHLs. Power is dissipated to the environment through heating of the conductor and joints, commonly referred to as “Joule heat” effect. In “steady state” conditions, the maximum allowable Ohmic losses are determined by the rate at which power can be transferred to the environment and the maximum operating temperature of the conductor. Losses are also experienced as a result of Corona discharge which occurs in High Voltage transmission lines when the air surrounding the conductors and fittings becomes ionised. However, proper selection of the conductor system reduces the corona losses to negligible levels compared to the ohmic losses. Dielectric losses are also experienced, which are largely produced by leakage currents through the electrical insulators, especially when pollution is deposited on them or when the insulating material is damaged. With proper design and adequate maintenance these losses are normally kept to very low levels and 	<ul style="list-style-type: none"> Similar to OHL, Ohmic losses are experienced in cable systems. However, power dissipation to the environment is much less effective (the conductors are surrounded with a ‘jacket’ of electrical insulation and are buried in the ground), consequently larger conductors must be used and resistive losses are much lower. Cables do not experience corona losses. Dielectric losses in cable systems are more critical than in OHL due to the volume of insulating material and the high electrical stresses. However, modern insulating materials are very effective and these losses are generally still negligible compared to the Ohmic losses. HV cables are enclosed in a conducting outer sheath, which experiences high levels of electromagnetic field from the conductor. If these are not managed, then significant induced currents will flow in the sheath and the resulting losses can be significant. However, onshore HVAC cable systems for power 	<ul style="list-style-type: none"> An HVDC system will need either a cable or overhead line circuit to connect the two converter stations. As such the losses associated with these will need to be considered, although not all losses mentioned in the previous columns apply to HVDC systems. The DC resistance of a practical conductor is lower than the AC resistance and the electrical current flowing is only associated with the ‘true’ power being transferred (there is no reactive power associated with DC systems). Consequently, resistive losses are typically lower in a HVDC circuit compared with a HVAC circuit of similar capacity. However, there are losses associated with each converter station. These result from both the AC and DC equipment, but also from ancillary systems such as cooling etc. Typical values of full load losses are 1% for each converter station (based on Voltage Source Converter technology). These losses are predominantly resistive and, since HVDC circuits modulate power flow by controlling electrical current in the circuit, they are related to the square of the power flow (e.g. at 50% power

⁵⁴ For example, this means that if the current is doubled then the losses increase by a factor of 4 (2²), or if the current is multiplied by 3 then the losses increase by a factor of 9 (3²),

HVAC Overhead Line	HVAC Underground Cable	HVDC System
<p>have very little effect on the overall losses of a transmission line.</p> <ul style="list-style-type: none"> Electromagnetic fields can induce currents on the shielding wires or on conductors of parallel lines, thus causing inductive losses. These effects are typically small compared to ohmic losses. 	<p>transmission are generally designed to minimise these currents (through the use of 'special bonding') and these losses are typically small. In offshore HVAC cables these effects are managed through 'bundling' the phases.</p> <ul style="list-style-type: none"> The 'apparent power' carried by a cable system is higher than the 'true' (i.e. effective) power being transferred. This is due to a 'reactive' component of the electrical current⁵⁵, which increases with cable length. Long HVAC cables thus see higher levels of resistive losses than would be expected from the true power loading. Whilst this is also the case for OHL, the reactive component is generally very low in comparison to UGC. For long underground cable systems it may be necessary to install compensation equipment at one or both ends to manage reactive power flows in the system. This equipment will have its own inherent losses. 	<p>transfer the losses are 25% of the full-load value).</p>

Source: Mott MacDonald

Further details are provided in the different technical appendices, and in Section I.3, as to the losses associated with each technology. Further, the assessment of non-cost characteristics also considers this as a factor in the assessment.

The previous report considered two main cost components in relation to these losses:

- The direct cost of the electrical energy which is “lost” during electricity transmission which is termed the energy loss. In order to assess the cost, the losses can be quantified in terms of kWh, and multiplied by a typical unit cost of electricity.
- The cost of installing additional generation capacity in order to compensate for these losses which is termed the power loss.

It is our view that valuing losses on the basis of the wholesale power cost (which necessarily has to recover the capital investment in the generating plant, the fixed maintenance costs and the marginal costs of operating that plant, such as fuel costs) provides a meaningful metric to facilitate comparison between different types of technologies. We have thus only considered energy losses in this updated report.

As losses are effectively the consumption of energy, they also have emissions associated with them. The most notable emission is CO₂. Whilst no separate cost has been allocated for managing the CO₂ emissions, a more detailed discussion on this topic is included in Appendix K., and the impact has been considered as part of the assessment of non-cost characteristics presented in Section 5.

I.2 Calculating the Cost of Energy Losses

As part of the whole life cost presented in Section 4 we have calculated estimated losses over the lifetime of the asset for the different technologies. As described in Section I.1, the resistive

⁵⁵ See the HV cables Technical Appendix for an explanation of reactive power.

losses are typically dominant and are proportional to the square of the current flowing in the conductor and, in reality, this varies as demand on the network changes and generation patterns change through the day. Therefore, certain assumptions have been made to allow an indicative assessment to be made, and the figures presented are a very simplistic representation of what may occur. The results are purely to allow a meaningful comparison between the technology types and are based on assumptions and a simplified approach. The figures presented are not representative of real world conditions, and should not be used to estimate likely losses for particular systems or technologies. Calculation of losses is a complex subject and specific calculations must be undertaken, accounting for the context and conditions in which the technology is to be deployed.

The following assumptions have been used:

- The capacity and lengths of the transmission circuits studied are detailed in Section 3 of this report.
- The system voltage considered is 400 kV (nominal).
- For the purposes of calculating losses, the average circuit load on the onshore transmission system is assumed to be 34%⁵⁶ of winter post fault continuous capacity of the circuit. This is referred to as the circuit loading factor (CLF), and is assumed to remain steady over the asset lifetime.
- We have not identified a suitable data source in respect of the loading of offshore transmission assets, which are used in a different way to the onshore transmission system. For comparison purposes, calculation of losses for the offshore technologies assumes the assets are operating at full capacity. It is recognised that in practice this will only be true for a small proportion of the operational time and therefore a sensitivity has been provided in the cost analysis indicating the potential impact of using 34% and 50% loadings.

The calculation methodology is shown in Table I.2.

Table I.2: Cost of energy losses methodology

Step	Mott MacDonald Comments and Assumptions
For each technology, estimate in MWh the annual losses	<ul style="list-style-type: none"> • Estimation has been undertaken against each specific technology listed in Section 3 of this report. • We have considered sources of losses which could realistically be expected for a transmission system, including those listed in Table I.1.
Multiply by representative £/MWh figure	<ul style="list-style-type: none"> • Given that losses vary depending on system load, their cost is recovered from Users in line with the balancing and settlement code (BSC) which is administered by Elexon (https://www.elexon.co.uk/operations-settlement/balancing-and-settlement/transmission-losses/). • The cost associated with this is dependent on system pricing which is difficult to predict (https://www.elexon.co.uk/operations-settlement/balancing-and-settlement/imbalance-pricing/#more-about-pricing). • In 2022, energy prices in the UK and across Europe have been experiencing significant increases and volatility. Multiple factors have contributed to this scenario including the Ukraine-Russia conflict and a global post-COVID recovery which has caused demand for gas to increase. • Prior to this period, an industry benchmark of £50/MWh was commonly used for estimating purposes. This figure is still used as a representative example on the NG ESO website

⁵⁶ NGET_A11.11 Transmission Loss Strategy,” National Grid, Dec. 2019. [Online]. Available: <https://www.nationalgrid.com/electricity-transmission/document/132276/download>

Step	Mott MacDonald Comments and Assumptions
Use discounted cash-flow technique to estimate present value over lifetime of asset, allowing the future cost of losses to be considered on the same basis as the capital cost estimate	<p data-bbox="858 302 1385 376">https://data.nationalgrideso.com/demand/transmission-losses). However, these values are unlikely to be representative of future costs.</p> <ul data-bbox="810 389 1422 1048" style="list-style-type: none"> <li data-bbox="810 389 1422 517">● Independent analysts Cornwall Insight predict both summer and winter 2023 prices to be close to £100/MWh (refer to Cornwall Insight document “Energy Spectrum” dated 9th January 2023). For the purposes of this report we have selected £90/MWh. <li data-bbox="810 530 1422 636">● Considering that the purpose of this report is to compare different technologies against each other, no sensitivity analysis has been provided to show the impact of changes to this rate <li data-bbox="810 651 1422 725">● For its latest transmission price control Ofgem has used an average cost of equity of 4.25%⁵⁷ which was specified in February 2021. <li data-bbox="810 739 1422 844">● As with market prices, inflation and interest rates are currently going through a period of volatility and current rates are not considered to be representative of future expectations. <li data-bbox="810 857 1422 931">● Based on these two factors and our own experience, we consider a figure of 5% to be a representative example for the purposes of this study. <li data-bbox="810 945 1422 1048">● Considering that the purpose of this study is to compare different technologies against each other, no sensitivity analysis has been provided to show the impact of changes to this rate.

1.3 Assessment of Losses

In order to illustrate the performance of different technologies in respect of losses we have provided Table I.3 and Table I.4 for comparison of onshore and offshore technologies respectively. In some instances it is not possible to undertake an accurate quantitative assessment, and therefore a qualitative explanation is provided, with such areas described in Table I.5. As previously explained, resistive losses tend to be dominant and, whilst (for a specific conductor system) resistance is linearly dependent on circuit length, losses are proportional to the square of the current. For illustration purposes we have (where appropriate) considered the medium length of circuits, but varied the circuit rating.

It is crucial that onshore technologies are not directly compared with offshore technologies. This is due to the different way in which the technologies are used, and therefore the different assumptions which we have applied to the calculations. For onshore circuits, the figures are presented per double circuit and are based on 34% loading as per the assumptions set out in the preceding sections and use a 15 km route length. For offshore circuits, the figures presented are for the system as a whole and are based on 100% loading, and use a 180 km route length. Due to this difference in lengths, loadings, and topology the figures presented should not be used as a comparison between the performance of onshore or offshore technologies.

In practice, offshore transmission systems including embedded HVDC links may run more flexibly to take account of changing generation and system conditions leading to a wide range of utilisation levels with the average depending on what the system is being used for (e.g. point-to-point connection of an offshore wind farm into the main onshore network, an interconnector or an embedded HVDC link). Therefore sensitivities are presented in the costing section for these technologies, indicating the potential impact on cost assessments for 34% and 50% loading.

⁵⁷ https://www.ofgem.gov.uk/sites/default/files/docs/2021/02/final_determinations_-_finance_annex_revised_002.pdf

For some of the alternative technologies, a direct comparison would not be possible, and a quantitative assessment may not be straightforward, therefore a qualitative opinion is provided.

For each of the onshore and offshore technologies, per each rating case the following has been presented:

- Annual energy lost, in MWh.
- Cost of annual energy lost, in £.
- Percentage of annual energy lost, derived from annual energy lost divided by the total energy that was produced, in%.

I.3.1 Onshore Technology Losses

Table I.3: Onshore technologies annual losses comparison (34% loading)

Description	High Rating (1,836 A per circuit)	Medium Rating (1,224 A per circuit)	Low Rating (612 A per circuit)	Mott MacDonald Comments
Onshore, 15 km route length				
400 kV Overhead Line	<ul style="list-style-type: none"> • 38,778 MWh • £3,409,062 • 0.18% 	<ul style="list-style-type: none"> • 21,294 MWh • £1,916,473 • 0.15% 	<ul style="list-style-type: none"> • 7,440 MWh • £669,642 • 0.11% 	<ul style="list-style-type: none"> • Considering double circuit OHL.
400 kV Underground Cable – Direct Buried	<ul style="list-style-type: none"> • 17,077 MWh • £1,536,953 • 0.08% 	<ul style="list-style-type: none"> • 11,383 MWh • £1,024,431 • 0.08% 	<ul style="list-style-type: none"> • 5,689 MWh • £511,973 • 0.08% 	<ul style="list-style-type: none"> • These losses do not consider reactive power compensation devices required for longer length UGC.
400 kV Underground Cable – In Tunnel	<ul style="list-style-type: none"> • 19,923 MWh • £1,793,058 • 0.094% 	<ul style="list-style-type: none"> • 12,826 MWh • £1,154,334 • 0.091% 	<ul style="list-style-type: none"> • 6,538 MWh • £588,427 • 0.093% 	<ul style="list-style-type: none"> • UGC Tunnel losses are higher due to greater heat dissipation as each cables experience a larger load. The low case uses one conductor per phase, whereas the medium and high cases both use two conductors per phase. The high case requires greater ventilation. Ventilation system losses have not been included within these figures.
400 kV Gas-insulated Line – Direct Buried/In Tunnel	<ul style="list-style-type: none"> • 21,710 MWh • £1,953,904 • 0.108% 	<ul style="list-style-type: none"> • 9649 MWh • £ 868,402 • 0.072% 	<ul style="list-style-type: none"> • 2,412 MWh • £ 217,100 • 0.034% 	<ul style="list-style-type: none"> • Due to the considerable conductor cross-sectional area, the resistive losses in these systems tend to be lower than OHL. Ventilation system losses were not factored into these figures.
400kV Pressurised Air Cable – In Pipe	<ul style="list-style-type: none"> • 16,661 MWh • £1,499,508 • 0.083% 	<ul style="list-style-type: none"> • 7,405 MWh • £666,448 • 0.055% 	<ul style="list-style-type: none"> • 1,851 MWh • £166,612 • 0.028% 	<ul style="list-style-type: none"> • Calculated using representative data as product still in development. • Low case uses one conductor per phase, Medium and High cases use two conductors per phase. For these circuits a fixed value of loss per km was applied.

Source: Mott MacDonald

We can observe the following points from this table:

- All technologies have relatively low losses in percentage terms.
- For underground cables, the percentage losses are the same for all ratings cases. This is because, whilst we are increasing the load for each rating increment, we are also increasing the number of conductors in proportion.
- A cable in a tunnel has slightly higher losses as compared to a direct buried cable

- Overhead line losses are slightly higher than those of underground cables, but in overall terms are still low.
- The pressurised air cable is indicated to have the lowest losses of all technologies examined.

As part of the cost assessment in Section 4 we have examined and drawn conclusions in respect of the economic considerations, considering the different capital costs and the cost impact of increased losses over the operational lifetime of an asset.

I.3.2 Offshore Technology Losses

As previously stated, our calculations for offshore technologies have been produced based on the assets operating at 100%. This is because the offshore technologies are assumed to be in a point-to-point topology, for example connecting offshore generation to an onshore point of connection, hence regularly operating at 100% loading. This comparison does not consider an “embedded link” topology, where the circuit is used to connect two displaced onshore sites, where different loading patterns may be seen.

Table I.4: Offshore technologies annual losses comparison (100% loading)

Description	High Rating	Medium Rating	Low Rating	Mott MacDonald Comments
Offshore, 180 km route length				
HVDC Cable with Voltage Source Converter	<ul style="list-style-type: none"> • 442,492 MWh • £39,824,310 • 2.53% 	<ul style="list-style-type: none"> • 262,561 MWh • £23,630,455 • 3.00% 	<ul style="list-style-type: none"> • 125,471 MWh • £11,292,355 • 2.86% 	<ul style="list-style-type: none"> • Each converter defined as 1% loss, with 2 converters per circuit.
HVAC Submarine Cable	<ul style="list-style-type: none"> • 610,217 MWh • £54,919,563 • 3.48% 	<ul style="list-style-type: none"> • 305,109 MWh • £27,459,781 • 3.48% 	<ul style="list-style-type: none"> • 152,554 MWh • £13,729,891 • 3.48% 	<ul style="list-style-type: none"> • Full load losses assumed to be a fixed value.

Source: Mott MacDonald

Based on the above we can observe that for a distance of 180 km, the HVDC solution has lower losses in all cases, as compared to the HVAC solution. We have investigated the relationship between losses and circuit length for each technology in order to assess an approximate “break even point” (important note – this is the break even point in respect of losses only, not in respect of capital cost). At shorter distances the HVDC VSC system has greater losses due to fixed loss per converter, which we have defined as 1% (a typical industry reference point) for these calculations, and hence a minimum of 2% per circuit without taking into account losses through the cable. However, at greater distances the AC cable conductor losses begin to dominate, with this break-even point at approximately 150 km, as shown in Figure I.1.

Figure I.1: Submarine AC versus HVDC Losses

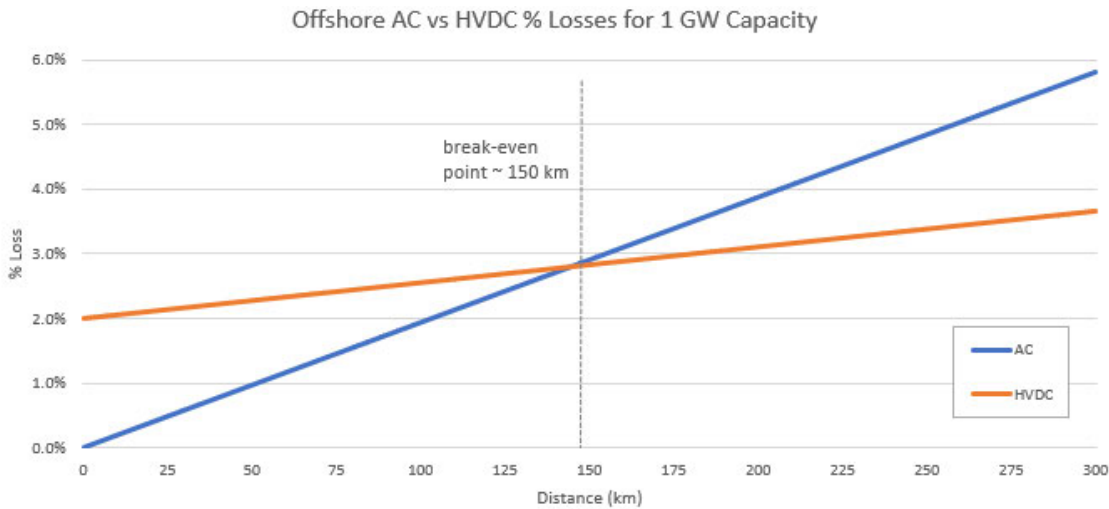

Source: Mott MacDonald

As with the onshore technologies, Section 4 of this report examines and draws conclusions in respect of the economic considerations, considering the different capital costs and the cost impact of increased losses over the operational lifetime of an asset.

I.3.3 Alternative Technology Losses

Table I.5: Alternative technologies annual losses comparison

Description	Mott MacDonald Comment
Multi-terminal HVDC Link – three terminal 2,000 MW bi-pole using 525 kV XLPE 2,500 mm² copper cable	<ul style="list-style-type: none"> Assuming the same parameters as the offshore “high” rating above but with three converter stations and two cable circuits each of 180 km length, 100% loading, the following losses could be expected: <ul style="list-style-type: none"> 709,785 MWh per annum. £63,880,000 per annum. 4.05%.
Alternative Tower Technologies	<ul style="list-style-type: none"> Changing tower technologies expected to have negligible impact on losses.
Superconducting Cable	<ul style="list-style-type: none"> The resistivity of superconductors is extremely low, with effectively no resistive losses across the conductor. However, there are losses associated with the cryogenic cooling system that need to be considered. These include losses associated with the powering of the cooling system itself, and others due to thermal leak through the insulation, hydraulic and pumping losses, plus those losses at the joints and terminations.
Increasing Use of Existing Thermal Capacity – Quadrature Booster	<ul style="list-style-type: none"> Series compensation technologies do not reduce the line losses, as they do not affect the inherent resistance of the circuits where they are installed (only the apparent resistance changes). Furthermore, there are additional losses associated with the series compensation equipment (for example, quad boosters have the same losses associated with transformers due to resistive losses in the windings). However, if none of the nearby network circuits are near thermal capacity, these devices can be temporarily bypassed to eliminate their loss contribution.
Increasing Use of Existing Thermal Capacity – Thyristor Controlled Series Capacitor	
Increasing Use of Existing Thermal Capacity – Static Series Synchronous Compensator	
Onshore HVDC – 2 GW bi-pole VSC using 525 kV XLPE cable over 700 km route length	<ul style="list-style-type: none"> The following losses could be expected at 34% loading: <ul style="list-style-type: none"> 391,801 MWh per annum. £35,262,056 per annum.

Description	Mott MacDonald Comment			
	<ul style="list-style-type: none"> – 6.58%. 			
Onshore HVDC – 8 GW LCC bi-pole using overhead line over 700 km route length	<ul style="list-style-type: none"> ● The following losses could be expected at 34% loading: <ul style="list-style-type: none"> – 2,177,459 MWh per annum. – £195,971,345 per annum. – 4.57%. 			
Reconductoring of Existing OHL with HTLS Conductor	<ul style="list-style-type: none"> ● Reconductoring usually involves upgrading an existing OHL to HTLS conductor, increasing thermal capacity at a relatively similar efficiency. As the amount of power transferred increases, so does overall energy lost but the rate of loss per MW stays relatively constant. Assuming the same parameters as the “high” rating above with 34% loading for the following route lengths: <table style="width: 100%; border: none;"> <tr> <td style="width: 33%; vertical-align: top;"> <ul style="list-style-type: none"> ● 3 km Route <ul style="list-style-type: none"> – 13,595 MWh. – £1,223,514. – 0.06%. </td> <td style="width: 33%; vertical-align: top;"> <ul style="list-style-type: none"> ● 15 km Route <ul style="list-style-type: none"> – 67,973 MWh. – £6,117,971. – 0.32%. </td> <td style="width: 33%; vertical-align: top;"> <ul style="list-style-type: none"> ● 75 km Route <ul style="list-style-type: none"> – 339,865 MWh. – £30,587,856. – 1.61%. </td> </tr> </table> 	<ul style="list-style-type: none"> ● 3 km Route <ul style="list-style-type: none"> – 13,595 MWh. – £1,223,514. – 0.06%. 	<ul style="list-style-type: none"> ● 15 km Route <ul style="list-style-type: none"> – 67,973 MWh. – £6,117,971. – 0.32%. 	<ul style="list-style-type: none"> ● 75 km Route <ul style="list-style-type: none"> – 339,865 MWh. – £30,587,856. – 1.61%.
<ul style="list-style-type: none"> ● 3 km Route <ul style="list-style-type: none"> – 13,595 MWh. – £1,223,514. – 0.06%. 	<ul style="list-style-type: none"> ● 15 km Route <ul style="list-style-type: none"> – 67,973 MWh. – £6,117,971. – 0.32%. 	<ul style="list-style-type: none"> ● 75 km Route <ul style="list-style-type: none"> – 339,865 MWh. – £30,587,856. – 1.61%. 		
UHV Onshore AC Transmission using 765 kV OHL over 700 km route length	<ul style="list-style-type: none"> ● Using an ACSR conductor configuration, the following single circuit losses could be expected for 34% loading, considering a circuit rating of 8,000 MVA: <ul style="list-style-type: none"> – 1,292,299 MWh per annum. – £116,306,911 per annum. – 5.42%. ● For comparison purposes, single circuit losses at 50% capacity (i.e. transferring a total of 8 GW) may be as follows: <ul style="list-style-type: none"> – 2,794,764 MWh per annum. – £251,528,787 per annum. – 7.98%. ● By comparison, the losses for a single circuit at 100% loading may be as follows: <ul style="list-style-type: none"> – 11,179,057 MWh per annum. – £1,006,115,148 per annum. – 15.95%. 			

Source: Mott MacDonald

In respect of the alternative technologies, it is difficult to undertake a comparison in respect of losses as each technology would be expected to be selected to meet a particular network requirement. It is unlikely that losses would be a key decision driver in such circumstances.

J. Environmental

J.1 Introduction

This appendix seeks to outline the high-level environmental considerations associated with different electricity transmission technologies.

Whilst previous studies have set out a common list of environmental issues associated with electricity transmission technologies as one topic, there has not been any consideration of technologies and their associated constraints as separate entities. Environmental considerations and impacts will vary, depending on the type of technology being developed.

It should be noted that to determine the applicable environmental impacts of the technologies outlined above, an understanding of the site or project specific constraints and surrounding environment is required. As such, environmental impacts can largely vary on the basis of where particular technologies are located in a particular context. There are a range of direct and indirect environmental considerations and impacts for all technologies, both in construction and during operation.

Set out in Section J.2 is a comparable analysis of environmental considerations associated with the different electricity transmission technologies reviewed.

J.2 Key Environmental Considerations associated with Electrical Transmission Technologies

Table J.1 sets out the potential environmental considerations associated with different electricity transmission technologies. Each technology is considered separately, to account for the potential variation of impacts associated with each environmental consideration during construction and/or operation. Both direct and indirect impacts are considered, to account for how construction and operational activities impact the listed environmental considerations.

For decommissioning, two options are assumed; technologies would either be left in-situ or removed. If left in-situ, no additional impacts are anticipated. If technologies are to be removed, it is considered that impacts would be in line with those given for construction. While there is a lack of sufficient data for full assessment, a general assumption can be made that metals and concrete in OHL, and above ground assets in principle, are easier to recover and recycle compared to underground or subsea cables. In addition, cable insulation materials such as cross-linked polyethylene are presently assumed to be not recyclable. For more information on the carbon considerations, see Section K.2.3.

As previously mentioned, environmental impacts are largely dependent on the type of technology and the context of the surrounding environment where it is to be constructed. Individual environmental considerations and the possible resulting impacts can therefore vary in magnitude due to context. The relative significance of impacts will also vary dependent on the mitigation provided, with the scale and significance of impacts reducing with increased mitigative measures.

J.3 Comparative Impacts Respective to Technology Selection

Detailed in Table J.1 is an on-balance comparative analysis of impacts associated with each technology during construction and operation. Additionally, to provide an understanding of how the technologies compare against each other, a score from highest impact (1) to lowest impact (5) is provided for each environmental topic, as illustrated in Figure J.1. It is understood that the magnitude of impact would vary for each technology dependent on location. Therefore, this comparative scoring provides an initial high-level indication of constraints associated with the applicable technologies. The scoring is a qualitative assessment undertaken by Mott MacDonald environmental team members in conjunction with the wider project team. This is a generic assessment by nature, and each individual project will need to be considered in its specific context.

Figure J.1: Impact Scoring

Grade	Score	Impact
	1	Highest impact  Lowest impact
	2	
	3	
	4	
	5	

Table J.1: High-level comparative impacts associated with technologies

	Onshore overhead lines	Onshore underground cables	Onshore new substations/ substation extensions	Submarine cables	Offshore new substations
Geology, soils and sediment					
Construction	3	1	4	2	3
Operation	4	4	5	2	2
	Isolated excavations at pylon locations, however, would require material movements off site. Potential for contamination of soils and groundwater during operation via site activities.	Extensive excavation activities during construction. Extensive material movements. Potential for excavation to be required during operations, but only in the event of a failure leading to repair.	Limited excavations required requiring low levels of materials to be moved off site. Potential for contamination of soils and groundwater during operation via site activities but this is usually mitigated through design.	Extensive excavation activities during construction. Extensive material movements. Operational impacts from rock placements to sediment, could result in scour. This scour may occur repeatedly in mobile sediment areas.	Excavations required during construction. Impact on seabed as a result of platform foundations. Operational impacts resulting from change in hydrological regime resulting in scour.
Water					
Construction	4	2	5	1	3
Operation	5	4	3	4	4
	Potential for ground and surface water impacts due to piling activities and increased hardstanding areas. Operational impacts present minimal flood risk due to resilience to inundation.	May require river crossing which could give rise to hydrological constraints. Operational impacts present minimal flood risk due to resilience to inundation. Could be a ground and surface water impact during construction, and during operation due to the permanent presence of infrastructure below ground.	Potential for ground and surface water impacts due to increased hardstanding areas however efficient drainage can mitigate effects. An increase in impermeable area would increase potential for rainfall runoff rate and would require attenuation.	Potential for water quality impacts due to increased suspended sediment and pollution. During operation, minimal impact on water quality expected.	Potential for water quality impacts from pollution events, but this is usually mitigated through design.
Ecology					
Construction	3	2	4	1	2
Operation	3	4	4	3	3
	Potential for substantial impacts on habitats and protected species due to removal of habitats and potential for disturbance. Bird strikes during	Potential for substantial impacts on habitats and protected species due to removal of habitats and potential for disturbance. No notable impacts anticipated during operation,	Potential for isolated impacts on habitats and protected species. No significant ecology issues expected during operations but there are still issues which may need to be	Cables either buried in sea bed or protected with rocks. Potential for permanent loss of habitat, disturbance to ecology during construction, vessel strikes, water quality impact	Potential for permanent loss of habitat, ecology disturbance, vessel strikes, water quality (sedimentation, pollution event) impacts etc. During operation,

	operation also considered a potential impact.	although minor impact possible as habitats may not return to original condition, and potential requirement for repairs.	managed such as birds, bats and reptiles.	(sedimentation, pollution event) impacts etc. During operation, permanent habitat loss, and potential impact during surveys or reburial activities	permanent structure with potential impact on ecology.
Landscape and visual					
Construction	1	2	2	5	4
Operation	1	4	2	5	4
	Short- and long-term impacts for nearby and distant visual receptors. Potential impacts on landscape character and visual during operation.	Short-term landscape and visual impacts only. Long-term reinstatement anticipated therefore visual impacts not anticipated long-term during operation phase. It is recognised that in some instances long-term scarring can occur, but this is very project and location specific.	Short- and long-term impacts for nearby visual receptors. Permanent establishment with associated ongoing operational impact and attendance by operational personnel.	Vessel profile nearshore and foreshore plant, limited visual impacts during construction only. No impacts anticipated during operation unless repair/reburial works involving vessels and plant are required on the nearshore.	Vessel profile nearshore vessel movements during construction. During operation, visual impacts anticipated from the elevated substation.
Cultural heritage					
Construction	2	2	3	3	5
Operation	2	5	3	5	5
	Potential for short- and long-term visual impacts on the setting of nearby designated heritage receptors. Would seek to mitigate impact through design if possible.	Potential for short-term impacts for nearby heritage receptors. Long-term impacts not anticipated. Would seek to mitigate impact through design if possible.	Potential for short- and long-term visual impacts on the setting of nearby heritage receptors. Would seek to mitigate impact through design if possible.	Assuming cable route would avoid any heritage assets (identified during seabed survey). During operation, no impacts are anticipated.	Assuming placement of substation would avoid any heritage assets (identified during seabed survey). During operation, whilst a permanent structure is present, this is located offshore and cultural heritage impact is not expected.
Traffic					
Construction	2	1	2	3	5
Operation	4	5	4	5	3
	Potential short-term construction traffic impacts associated with haul route and	Potential short-term construction traffic impacts anticipated. More frequent movement anticipated	Potential short-term construction impacts anticipated due to plant	Potential short-term marine construction traffic anticipated. No long-term impacts	Potential short-term marine construction traffic anticipated. Other marine vessels may need

<p>plant movements. No long-term impacts anticipated. Overhead lines would be subject to annual inspections from the ground and as such required vehicle access.</p>	<p>due to material movements off site. No long-term impacts anticipated.</p>	<p>movements. No long-term impacts anticipated. During operation, the volume of traffic due to be generated would be minimal with only infrequent vehicle access required.</p>	<p>anticipated. Other marine vessels may need to be diverted from construction area. During operation, normally no impact, although potential for impacts from increased vessel traffic relating to maintenance (regular surveys) which would increase if reburial is required using specialised vessels and exclusion zones for fishing/recreational vessels.</p>	<p>to be diverted from construction area. Operational vessel movements to maintain the substation likely required.</p>
--	--	--	--	--

Noise and vibration					
Construction	3	3	5	3	3
Operation	3	5	3	4	3
<p>Haul route and plant movements have potential to generate noise and vibration impacts. Construction of foundations, assembly of towers, and stringing activities have potential to generate additional impacts. Potential for operational noise impacts. The design should consider the placement of overhead lines in proximity to sensitive noise receptors.</p>	<p>Haul route and plant movements have potential to generate noise and vibration impacts. Trench excavation and cable pulling would also have an impact, which may be increased if any directional drilling is required. Underground cables are practically quiet in operation and therefore long-term impacts are not anticipated.</p>	<p>Haul route and plant movements have potential to generate noise and vibration impacts. Potential for operational noise impacts. Substations have the potential to result in operational noise. The design should consider the placement of substations in proximity to sensitive noise receptors.</p>	<p>Potential for construction noise and vibration from vessels, dredging of the trench for the cable and rock dumping (to protect the cable). During operation, maintenance (reburial) requiring specialised vessels may have noise and vibration impacts, but likely to be infrequent.</p>	<p>Potential for construction noise and vibration, potential for significant adverse effects if piling is required due to propagation of noise through the water column. Whilst this is less likely to affect the human population compared to works taking place onshore, the impact on marine life requires careful consideration, and noise can sometimes also propagate through the seabed, impacting on residents onshore. During operation, increased noise as a result of vessel activity for maintenance and from the operation of the substation itself.</p>	

Air quality					
Construction	2	1	4	3	5
Operation	5	5	5	4	4
	Extensive excavation and material movements off site have potential to generate moderate air quality impacts during construction. The only operational air quality impacts anticipated would be due to potential emissions of future maintenance.	Extensive excavation and material movements off site have potential to generate substantial air quality impacts during construction. The only operational air quality impacts anticipated would be due to potential emissions of future maintenance.	Excavation of materials would be required, however not considered extensive in comparison to other options. Potential for long-term air quality impacts however considered negligible.	Although excavations not required, movement of materials has potential to generate air quality impacts. During operation, if maintenance required, increased emissions from specialised vessels could impact on air quality.	Excavation of materials would be required, however not considered extensive in comparison to other options. Increase in emissions from vessels operating to and from the substation for routine maintenance/repairs.
Communities					
Construction	2	1	4	3	5
Operation	3	4	5	4	4
	Short-term impacts on communities considered substantial in comparison to alternative technologies. During operation, impacts anticipated as a result of ongoing effects on businesses and recreational users.	Potential impacts on communities are considered more substantial than alternative technologies due to short- and long-term processes required. However, operational impacts considered minimal.	Potential for short- and long-term impacts on communities if technology in close proximity to community receptors. Operational impacts considered low.	Potential for short-term impacts on fisheries and aquaculture. Long-term impacts not anticipated. During operation, potential for impacts from increased vessel traffic relating to maintenance (reburial) requiring specialised vessels and exclusion zones for fishing/recreational vessels.	Potential for short-term impacts on fisheries and aquaculture. Long-term impacts not anticipated. During operation an exclusion zone for recreational and fishing vessels would be established around the substation.

Table J.1 provides a high-level generalised comparison of constraints between each technology. However, it should be noted that environmental constraints associated with each technology will vary on a context-specific basis and therefore the information presented should not be considered in isolation without the consideration of additional site-specific factors.

J.4 Environmental Cost Components

Table J.2 lists the typical environmental cost components, both during construction and operation, for each technology where applicable and relevant. Although the list is not exhaustive, it sets out the standard items which could be expected to be implemented to mitigate against adverse impacts.

It is assumed that best environmental practice (BEP) is the standard process to be followed when determining likely significant effects and the measures to mitigate those effects by applying the most appropriate combination of environmental control measures and strategies during all phases of project planning. As such, the development of all technologies, both onshore and offshore, would follow the Best Available Techniques principle. This principle assumes techniques would include both the technology used and the way in which the installation is designed, built, maintained, operated and dismantled⁵⁸. Furthermore, it is assumed that the mitigation hierarchy would be followed during the planning process for any of the technology assets to ensure negative impacts are limited as far as possible. First, mitigation measures to avoid significant adverse effects should be considered and, if this is not possible, then measures to reduce these effects should then be considered. Compensation measures, offsite enhancements and/or remediation measures should only be considered where it is not possible to avoid or reduce significant effects. General mitigation includes measures such as route selection, construction sequencing/timing, cable burial depth and method and cable type.

Environmental Impact Assessment (EIA) is assumed as a prerequisite process to ascertain a full and detailed understanding of impacts resulting from any electricity transmission technology. As such, this process is not listed in Table J.2. In addition to EIA, it is assumed that for any marine/intertidal work, a marine licence will be required.

Best practice measures during construction are assumed to mitigate risks that are likely to arise, in accordance with BEP. Best practice measures could be assumed as a generic list of measures set out within documentation such as an Environmental Management Plan (EMP). As such, these items will not be listed individually in Table J.2 below as it is expected that they would be noted within an EMP. The items listed below, however, do include possible measures which are considered critical components in the planning and design of electrical transmission technologies. It should be noted that components may vary considerably on a site-specific basis. Anticipated licences and consents typically included within the EMP have been included.

Table J.2: Potential environmental cost items associated with construction and operation

Environmental Topic	Onshore Requirements	Offshore Requirements
Geology, soils and sediment	Construction	<ul style="list-style-type: none"> ● Site-specific intrusive ground investigations. ● Waste classification testing and consents. ● Soil mapping.
	Operation	<ul style="list-style-type: none"> ● Sediment sampling. ● Silt curtains. ● Hydrological modelling to inform impacts to construction methods. ● Dredging management plan. ● Biosecurity plan.
	Operation	<ul style="list-style-type: none"> ● N/A. ● Hydrological modelling and design to reduce scour.

⁵⁸ Guidelines on Best Environmental Practice in Cable Laying and Operation”, OSPAR Commission, Feb. 2012. Available: https://www.gc.noaa.gov/documents/2017/12-02e_agreement_cables_guidelines.pdf

Environmental Topic	Onshore Requirements	Offshore Requirements	
Water	Construction	<ul style="list-style-type: none"> ● Flood Risk Assessment. ● Hydrological Impact Assessment. ● Discharge consents. ● Abstraction licenses. ● Flood Risk Activity Permits. ● Monitoring of surface water drainage systems. 	<ul style="list-style-type: none"> ● Sediment sampling for contaminants. ● Silt curtains. ● Hydrological modelling. ● Marine Pollution Emergency Response Plan. ● Dredging management plans. ● Biosecurity plan.
	Operation	<ul style="list-style-type: none"> ● Ongoing maintenance and monitoring programme of localised drainage infrastructure. 	<ul style="list-style-type: none"> ● N/A.
Ecology	Construction	<ul style="list-style-type: none"> ● Phase 1 habitat surveys. ● Targeted species-specific surveys. ● Protected species licenses. ● Habitats Regulations Assessment. ● Arboricultural Impact Assessment. ● New/replacement habitat. ● Land purchasing. ● Stakeholder engagement with Statutory Environmental Bodies. 	<ul style="list-style-type: none"> ● Hydrological modelling. ● Habitat assessment surveys. ● Environmental baseline (Physico-chemical and infaunal) surveys. ● Protected species licenses. ● Habitats Regulations Assessment. ● MCZ assessments. ● Biosecurity Risk Assessment produced. ● Stakeholder engagement with Statutory Environmental Bodies. ● Installation of more environmentally friendly cable protection measures (such as marine mattresses). ● Intertidal protection matting for plant and vehicles. ● Sound data base and monitoring. ● Selection of cable burial – ploughing technique would result in lower sediment disturbance. ● Land purchasing. ● Avoidance of night-time working/directional, hooded lighting. ● The use of silt curtains or other barriers in the nearshore areas to minimise sediment plumes. ● Works restriction zones and no anchorage zones. ● Biosecurity plan. ● Lighting control plan. ● Marine mammal management plan. ● Use of micro-routing to avoid sensitive receptors. ● Consideration of translocation.
	Operation	<ul style="list-style-type: none"> ● 5–10-year habitat maintenance and monitoring requirement. 	<ul style="list-style-type: none"> ● N/A.
Biodiversity Net Gain	Construction	<ul style="list-style-type: none"> ● Biodiversity Net Gain assessment and calculations. ● Enhanced habitat creation. ● Regeneration of existing habitats. ● Land purchasing. 	<ul style="list-style-type: none"> ● Habitat restoration/creation. ● Artificial reef/habitat creation. ● Land purchasing.
	Operation	<ul style="list-style-type: none"> ● 30-year habitat maintenance and monitoring requirement. 	<ul style="list-style-type: none"> ● N/A.
Landscape and visual	Construction	<ul style="list-style-type: none"> ● Landscape and Visual Impact Assessment. ● Screening mitigation and/or replacement planting. 	<ul style="list-style-type: none"> ● Landscape and Visual Impact Assessment.

Environmental Topic	Onshore Requirements	Offshore Requirements
	<ul style="list-style-type: none"> ● Consideration of alternative designs with potential for lower visual impact 	
	<p>Operation</p> <ul style="list-style-type: none"> ● Long-term landscape maintenance and monitoring programme. 	<ul style="list-style-type: none"> ● N/A.
Cultural heritage	<p>Construction</p> <ul style="list-style-type: none"> ● Written Scheme of Investigation. ● Pre-construction archaeological excavations. ● Geo-archaeological and paleoenvironmental sampling and analysis. ● Archaeological controlled strip, map and sampling. ● Field evaluations. ● Archaeological trial trenching. ● Topographic survey of earthworks. ● Archaeological watching brief. ● Post-excavation assessment. ● Stakeholder engagement with Statutory Environmental Bodies. 	<ul style="list-style-type: none"> ● Written Scheme of Investigation. ● Surveys. ● Works restriction zones and no anchorage zones.
	<p>Operation</p> <ul style="list-style-type: none"> ● N/A. 	<ul style="list-style-type: none"> ● N/A.
Traffic	<p>Construction</p> <ul style="list-style-type: none"> ● Transport Assessment. ● Traffic Management Plan. 	<ul style="list-style-type: none"> ● Works restriction zones and no anchorage zones. ● Navigation plan.
	<p>Operation</p> <ul style="list-style-type: none"> ● N/A. 	<ul style="list-style-type: none"> ● N/A.
Noise and vibration	<p>Construction</p> <ul style="list-style-type: none"> ● Monitoring surveys. ● Stakeholder engagement with Local Planning Authority. 	<ul style="list-style-type: none"> ● N/A.
	<p>Operation</p> <ul style="list-style-type: none"> ● Operational substation noise assessment. 	<ul style="list-style-type: none"> ● Operational substation noise assessment.
Air quality	<p>Construction</p> <ul style="list-style-type: none"> ● Air Quality Assessment. ● Monitoring surveys. 	<ul style="list-style-type: none"> ● N/A.
	<p>Operation</p> <ul style="list-style-type: none"> ● N/A. 	<ul style="list-style-type: none"> ● N/A.
Community	<p>Construction</p> <ul style="list-style-type: none"> ● Land purchasing. ● Compensation payments e.g. for damaged farmland or restricted access. ● Stakeholder engagement with Local Planning Authority. 	<ul style="list-style-type: none"> ● Navigation plan (to minimise impacts to local vessels/fishing activity and recreation).
	<p>Operation</p> <ul style="list-style-type: none"> ● N/A. 	<ul style="list-style-type: none"> ● N/A.

K. Carbon

K.1 Introduction

The initial Electricity Transmission Cost Study, published 2012, provided an authoritative cost analysis of the different transmission technologies. In this update, carbon⁵⁹ is incorporated into the broader analysis to ensure climate change impacts are recognised as part of the decision-making process.

This appendix focuses on the carbon emissions associated with the electricity transmission sector and the carbon impact of the specific technologies which have been assessed as part of this report as defined in the ToR.

Section K.2 outlines the influencing factors of carbon emissions from a life cycle perspective and provides an overview of carbon in the broader electricity transmission sector. Sections K.3 to K.6 detail the methodology of the carbon assessment and summarise the quantitative and qualitative assessments to provide a high-level comparison of the transmission technologies.

K.2 Emission Sources

K.2.1 Embodied Emissions

The emissions associated with the materials and manufacturing required for transmission infrastructure are variable and depend on each specific transmission technology. In general, the conductive materials required in electricity transmission infrastructure such as aluminium and copper, and structural metals such as steel, dominate the material emissions⁶⁰. Other carbon intensive materials such as concrete and aggregate, which are required for the civils aspects of the infrastructure, also commonly account for a large proportion of the embodied carbon footprint.

The emissions associated with the construction process within the transmission network are, again, varied and dependent on the specific technology. Past research has estimated that emissions during the construction stage (the transport of materials and construction plant use) for overhead lines (OHL), a common electricity transmission technology, are predominately from the fuel used in the delivery of towers to site and for excavation plant⁶¹. For direct buried or underground cables within a tunnel, most emissions during construction are made up of fuel consumption related to construction plant machinery i.e. tunnel boring machines, removal of earth and ventilation. Such emissions will be reduced if the construction process adopts fossil fuel-free transport and construction machineries. It is estimated that by 2050, construction will

⁵⁹ Carbon is used here to refer to carbon dioxide and other greenhouse gases (GHGs) which contribute to climate change. GHGs are the seven gases covered by the Kyoto Protocol: carbon dioxide (CO₂), methane (CH₄), nitrous oxide (N₂O), hydrofluorocarbons (HFCs), perfluorocarbons (PFCs), sulphur hexafluoride (SF₆) and nitrogen trifluoride (NF₃). These are measured in units of carbon dioxide equivalent (CO₂e) which express the impact of each gas in terms of the amount of CO₂ that would create the same impact.

⁶⁰ Harrison, GP, Maclean, EJ, Karamanlis, S & Ochoa, LF (2010), 'Life cycle assessment of the transmission network in Great Britain', *Energy Policy*, vol. 38, no. 7, pp. 3622-3631. Available at: <https://doi.org/10.1016/j.enpol.2010.02.039> [Accessed 21/11/2022]

⁶¹ Harrison, GP, Maclean, EJ, Karamanlis, S & Ochoa, LF (2010), 'Life cycle assessment of the transmission network in Great Britain', *Energy Policy*, vol. 38, no. 7, pp. 3622-3631. Available at: <https://doi.org/10.1016/j.enpol.2010.02.039> [Accessed 21/11/2022]

account for 30% of annual infrastructure CO₂ emissions⁶². Research has shown that in general the emissions resulting from the construction process are relatively modest in comparison with those resulting from operation over the entire useful life⁶³.

K.2.2 Operational Emissions

Whole life carbon emissions within the GB transmission network are dominated by operational emissions. Operational emissions are understood to be predominantly caused by electricity losses and sulphur hexafluoride (SF₆) leakages, with routine inspections contributing a modest level of emissions due to the fuel consumption of maintenance vehicles⁶⁴. However, as the UK government has committed to substantially decarbonise the electricity system by 2030, operational emissions will reduce significantly over time if the commitments are met⁶⁵

Sulphur hexafluoride (SF₆) is used in transmission due to its effective electrical insulating properties⁶⁶. However, it is a potent greenhouse gas (GHG) with 23,500 times higher global warming potential than CO₂⁶⁷. Operational leakage from switchgear and leakage when decommissioning substations can lead to substantial emissions⁶⁸. In 2021, more than 13,000 tCO_{2e} of SF₆ emissions were reported during electricity transmission by the three electricity transmission operators in Great Britain (National Grid Electricity Transmission, Scottish Power Transmission & Scottish Hydro Electricity Transmission)⁶⁹, although for context, overall carbon dioxide emissions from the UK energy sector are estimated to be approximately 82Mt in 2022, with power stations accounting for around 54Mt⁷⁰. It should be noted that there may be a high embodied carbon cost from replacing SF₆ equipment with non-SF₆ alternatives⁷¹. Still, such trade-offs should be considered due to the substantial emissions associated with SF₆ leakage.

⁶² SSE (2016), *Sustainability Statement 2016*. SSE. Available at: https://www.ssen-transmission.co.uk/globalassets/documents/environmental-discretionary-reward-edr/4604-sse-transmission-sustainability-statement_2016_printfriendly_final-2.pdf [Accessed 23/11/2022]

⁶³ Harrison, GP, Maclean, EJ, Karamanlis, S & Ochoa, LF (2010), 'Life cycle assessment of the transmission network in Great Britain', *Energy Policy*, vol. 38, no. 7, pp. 3622-3631. Available at: <https://doi.org/10.1016/j.enpol.2010.02.039> [Accessed 21/11/2022]

⁶⁴ Harrison, GP, Maclean, EJ, Karamanlis, S & Ochoa, LF (2010), 'Life cycle assessment of the transmission network in Great Britain', *Energy Policy*, vol. 38, no. 7, pp. 3622-3631. Available at: <https://doi.org/10.1016/j.enpol.2010.02.039> [Accessed 21/11/2022]

⁶⁵ Cytiva (2020). Going liquid nitrogen-free for low-impact cryopreservation. Available at: [https://cdn.cytivalifesciences.com/api/public/content/digi-31119-pdf#:~:text=The%20carbon%20footprint%20of%20liquid,of%20liquid%20nitrogen%20\(3\).](https://cdn.cytivalifesciences.com/api/public/content/digi-31119-pdf#:~:text=The%20carbon%20footprint%20of%20liquid,of%20liquid%20nitrogen%20(3).) [Accessed 18/01/2023]

⁶⁶ EPA (2022), *Sulfur Hexafluoride Basics*. EPA. Available at: <https://www.epa.gov/eps-partnership/sulfur-hexafluoride-sf6-basics> [Accessed 23/11/2022]

⁶⁷ Green House Gas Protocol (2016), *Global Warming Potential Values. Adapted from the IPCC Fifth Assessment Report*. Available online at: https://ghgprotocol.org/sites/default/files/ghgp/Global-Warming-Potential-Values%20%28Feb%2016%202016%29_1.pdf Accessed 23/11/2022]

⁶⁸ EPA (2022), *Sulfur Hexafluoride Basics*. EPA. Available at: <https://www.epa.gov/eps-partnership/sulfur-hexafluoride-sf6-basics> [Accessed 23/11/2022]

⁶⁹ Ofgem (2021), *Energy network indicators*. Ofgem. Available at: <https://www.ofgem.gov.uk/energy-data-and-research/data-portal/energy-network-indicators> [Accessed 23/11/2022]

⁷⁰ DESNZ (2023), 2022 UK GHG emissions, provisional figures. Available at: https://assets.publishing.service.gov.uk/government/uploads/system/uploads/attachment_data/file/1147372/2022_Provisional_emissions_statistics_report.pdf [Accessed 26/09/2023]

⁷¹ Ofgem (2022), *Sustainability First. ED2 Business Plans – Ofgem Call for Evidence. Annex 2 – DNO SF6 Strategies*. Available at: <https://www.ofgem.gov.uk/sites/default/files/2022-03/Sustainability%20First%20-%20RIIO%20ED2%20BPs%20-%20Response%20to%20Ofgem%20-%20Annex%20%20-%20SF6%20STRATEGIES%20-%20080222final.pdf> [Accessed 21/12/2022]

K.2.3 Decommissioning and Disposal

At the end-of-life stage of the transmission technology, some materials can be recovered or recycled to reduce its overall carbon impact by avoiding additional carbon and energy costs from the extraction, transportation, and processing of virgin materials for future new infrastructure within the system. The associated carbon savings can be significant, particularly for materials that are carbon intensive, such as metals.

The potential of recycling and the carbon associated with recovering and transporting recycled material are dependent on the specific transmission technology. It can be assumed that metals and concrete in OHL can be more effectively recovered and recycled in comparison to underground or submarine cables⁷². Materials such as cross-linked polyethylene (XLPE) can be assumed as currently not recyclable.

K.3 Emission Reporting in the Transmission Sector

K.3.1 Overview of Carbon in Electricity Transmission

In 2020, the UK electricity generation sector emitted over 52,000 ktCO₂e from 269,804 GWh of generated electricity, with an estimated 2% average transmission losses⁷³. The whole electricity sector accounts for 13% of the UK total emissions⁷⁴. The overall carbon intensity of the GB transmission system is dependent on asset lifetime, material composition, the make-up of specific assets as well as factors such as the volumes of electricity transmitted and the volume of electricity losses⁷⁵. Based on the Department for Business, Energy, and Industrial Strategy (BEIS) emission conversion factors, on average, CO₂ emitted per kWh due to grid transmission and distribution losses has reduced over time, from 0.0433 kgCO₂e in 2002 to 0.0192 kgCO₂e in 2022⁷⁶.

K.3.2 The Office of Gas and Electricity Markets (Ofgem) Carbon Reporting Requirements

Ofgem sets the 2021-2028 price control (RIIO-2) for the electricity network in Great Britain under its “Revenue = Incentives + Innovation + Outputs” (RIIO) model⁷⁷. Since December 2020, Ofgem requires electricity transmission licence holders to publish an Annual Environmental Report (AER) to provide transparency on their commitments against the RIIO-2 Environmental

⁷² Harrison, GP, Maclean, EJ, Karamanlis, S & Ochoa, LF (2010), 'Life cycle assessment of the transmission network in Great Britain', *Energy Policy*, vol. 38, no. 7, pp. 3622-3631. Available at: <https://doi.org/10.1016/j.enpol.2010.02.039> [Accessed 21/11/2022]

⁷³ National Grid ESO (2019). *Transmission Losses*. Available at: <https://www.nationalgrideso.com/electricity-transmission/document/144711/download#:~:text=On%20the%20Transmission%20network%2C%20the,lost%20over%20the%20distribution%20networks2>. [Accessed 12/12/2022]

⁷⁴ BEIS (2022), *Final UK greenhouse gas emissions national statistics: 1990 to 2020*. Available at <https://www.gov.uk/government/statistics/final-uk-greenhouse-gas-emissions-national-statistics-1990-to-2020> [Accessed 23/11/2022]

⁷⁵ Harrison et al (2010), *Life Cycle Assessment of the Transmission Network in Great Britain*. Available at: https://www.pure.ed.ac.uk/ws/files/21980985/Grid_Carbon_Footprint_Paper.pdf [Accessed 21/11/2022]

⁷⁶ BEIS (2022), *Government conversion factors for company reporting of greenhouse gas emissions*. Available at: <https://www.gov.uk/government/collections/government-conversion-factors-for-company-reporting> [Accessed 23/11/2022]

⁷⁷ Ofgem (2021), *Network price controls 2021-2028 (RIIO-2)*. Available at <https://www.ofgem.gov.uk/energy-policy-and-regulation/policy-and-regulatory-programmes/network-price-controls-2021-2028-riio-2> [Accessed 13/01/2023]

Action Plan⁷⁸. Aside from Scope 1 and 2^{79,80} business carbon footprint reporting (building energy use, operational transport, fugitive emissions, and fuel combustion), licensees must report annual transmission losses from their network, the share of total electricity transmitted, and Insulation and Interruption Gas (IIG) leakage, which needs to be reported in tonnes of CO₂e and also as a percentage of total inventory.

Ofgem requires transmission licensees to report the embodied carbon of new construction projects completed in the reporting year. Embodied carbon reporting should be reported in tCO₂e/£m, or other alternatives such as tCO₂e/km for cables and OHL, and tCO₂e/kV for substations. Methodologies must align with *PAS 2080 Carbon Management in Infrastructure*⁸¹ where possible and can be reported based on “final design” or “as built”. Ofgem acknowledges that when some information is not readily available to assess embodied carbon accurately, licensees should seek information from their suppliers or from carbon databases (e.g. Bath Inventory of Carbon and Energy (ICE), BEIS conversion factors for greenhouse gas reporting).

K.3.3 How Carbon is Considered by Transmission Operators

National Grid Electricity Transmission (NGET), Scottish & Southern Electricity Networks (SSEN) Transmission and Scottish Power Energy Networks (SPEN) Transmission have formed a collaboration group to develop a common capital carbon (carbon from the creation, refurbishment, to end-of-life treatment of infrastructure) reporting tool⁸² through the UK Reduction of Capital Carbon in Infrastructure: Transmission (ROCCIT) group⁸³. The Carbon Product Calculator will enable TOs and their suppliers to report capital carbon in their transmission assets. Data collected from the tool is shared amongst the three TOs using the UK Transmission Operator Carbon Asset Database. The ROCCIT group collectively uses the tool and database with the UK Transmission Operator Carbon Product Calculator to develop low-carbon technologies investment cases⁸⁴. The UK Transmission Operator Guidance Document is also developed alongside the tool to guide suppliers in developing carbon footprints for electrical equipment supplied to the transmission network⁸⁵.

NGET has set a carbon-neutral construction target by 2026 in the RIIO-2 business plan for electricity transmission and has included carbon management in its larger contracts tendering

⁷⁸ Ofgem (2021), *RIIO-2 Environmental Reporting Guidance Version 1.0*. Available at: https://www.ofgem.gov.uk/sites/default/files/docs/2021/03/riio-2_environmental_reporting_guidance_v_1_final.pdf [Accessed 24/11/2022]

⁷⁹ According to the GHG Protocol, Scope 1 refers to direct emissions that occur from sources that are owned or controlled by the company. Scope 2 refers to indirect emissions that derive from the generation of purchased electricity consumed by the company. Scope 3 comprises of other indirect emissions that are from sources not owned or controlled by the company.

⁸⁰ GHG Protocol (2004). *The GHG Protocol Corporate Accounting and Reporting Standard*. Available at: <https://ghgprotocol.org/sites/default/files/standards/ghg-protocol-revised.pdf> [Accessed 22/02/2023]

⁸¹ Construction Leadership Council (2019). *Guidance Document for PAS 2080*. Available at: https://www.constructionleadershipcouncil.co.uk/wp-content/uploads/2019/06/Guidance-Documents-for-PAS2080_vFinal.pdf [Accessed 21/12/2022]

⁸² The Carbon Product Calculator and Transmission Operator Carbon Asset Database are collectively used by the ROCCIT collaborative group and are not externally validated.

⁸³ SP Energy Networks (2022), *SP Transmission Annual Environmental Report 2021/2022*. Available at https://www.spenergynetworks.co.uk/userfiles/file/39727_Transmission_Annual_Environmental_Report_Commitments_2021-2022%20final_online_version.pdf [Accessed 24/11/2022]

⁸⁴ SSE (2022), *Powering change together. SSE PLC Sustainability Report 2022*. Available at <https://www.sse.com/media/bgnpiq2x/sustainability-report-2022-v1.pdf> [Accessed 24/11/2022]

⁸⁵ Supply Chain Sustainability School (2022), *National Grid*. Available at: <https://www.supplychainschool.co.uk/partners/national-grid/> [Accessed 23/11/2022]

processes⁸⁶. National Grid has also developed an in-house Carbon Interface Tool (CIT), which is for contractors to estimate the carbon impact of infrastructure construction projects⁸⁷. The tool will be applied in future tenders to provide incentives for suppliers to reduce their carbon impact. The data collected will also be used to define best practice standards and carbon intensity reduction targets for construction schemes.

SSEN Transmission has adopted various governance and corporate reporting commitments to assess its own carbon impact. For example, sustainability criteria, which include whole life carbon costs, have been embedded in supply chain reporting, and throughout capital project investment decision-making and procurement⁸⁸. Electricity losses are included in selection criteria during the upgrade and construction of OHL. SSEN Transmission has also set net zero commitments and targets to reduce emissions throughout scope 1, 2 and 3, particularly for SF₆ emissions and emissions from transmission losses. SF₆ alternatives have also been installed and trialled within the network (e.g. 400 kV green gas substation (g³) at Kintore).

K.4 Assessment Methodology

The level of depth for the assessment of each transmission technology is dependent on the level of data available for that technology. Therefore, this assessment involves a mix of high-level quantitative and qualitative analysis for the following reasons:

8. **The nature of this report is not project specific**, and therefore no detailed data or design plans are available for assessment. The purpose of the report is to compare different technologies in relative terms, as opposed to undertaking a project specific assessment. It should be noted that carbon content would have project-specific variations. For example, the same technology type but from different suppliers may have different material composition. The total transport distance and travel mode of materials would also vary based on specific project location and scale (e.g. long vs short route lengths). While the Royal Institution of Chartered Surveyors (RICS) guidance document, *Whole Life Carbon Assessment for the Built Environment*⁸⁹, provides default values for some calculations, the diversity, in terms of potential project scale and type for each technology, involved in this study would not be suitable for an in-depth numerical comparison.
9. **Some carbon information, particularly for alternative technologies, is not readily available**. At the time of this report being conducted, the reporting of carbon associated with transmission equipment is relatively new and emerging. Databases developed by Transmission Operators are often not publicly available. This has resulted in a number of technologies being qualitatively assessed.

⁸⁶ The Green Construction Board (2021), *Good progress but not fast enough*. Available at: https://www.constructionleadershipcouncil.co.uk/wp-content/uploads/2021/04/Infrastructure-Carbon-Review-seven-years-on_March-2021.pdf [Accessed 23/11/2022]

⁸⁷ National Grid (2021), *Our 2021-2026 Environmental Action Plan*. Available at: <https://www.nationalgrid.com/electricity-transmission/document/136551/download> [Accessed 23/11/2022]

⁸⁸ SSEN (2022), *SSEN Transmission Sustainability Report 2021/2022*. Available at: <https://www.ssen-transmission.co.uk/globalassets/documents/sustainability-strategy/sustainability-report-2021-22.pdf> [Accessed 23/11/2022]

⁸⁹ RICS (2017). *Whole Life Carbon Assessment for the Built Environment 1ST Edition*. RICS. Available at: <https://www.rics.org/uk/upholding-professional-standards/sector-standards/building-surveying/whole-life-carbon-assessment-for-the-built-environment/> [Accessed 21/12/2022]

K.4.1 Emission Scope

The carbon assessment refers to the PAS 2080⁹⁰ infrastructure life cycle stages, as illustrated in Figure K.1. Due to data limitations, only some lifecycle stages are included within the quantitative assessment, namely the emissions related to the construction and operation of the project, including the required materials, the transport of those materials to site, as well as the transmission losses in operation. Stages that are considered in the assessment are highlighted in blue in Figure K.1.

Figure K.1: PAS 2080 infrastructure assessment life cycle stages

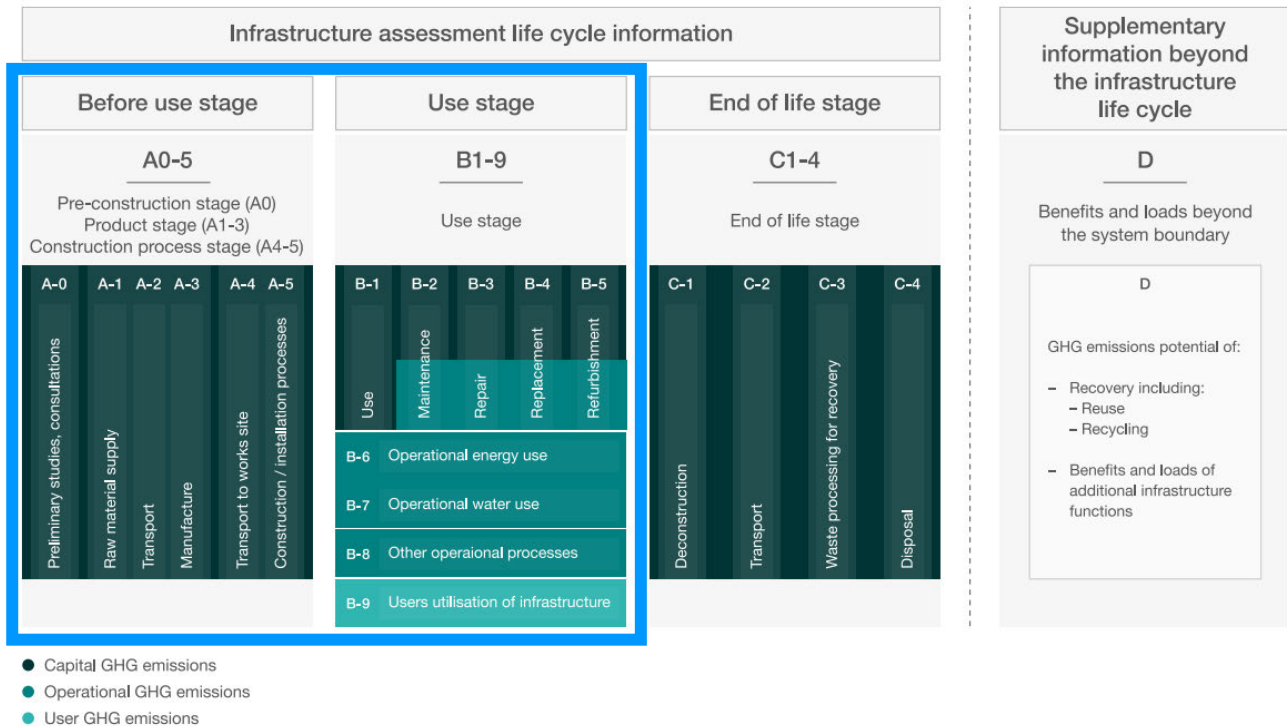

Source: The British Standards Institution (2016). PAS 2080: 2016. Carbon Management in Infrastructure

K.4.2 Carbon Calculation

Where estimated data is available, carbon is measured based on the rate of activity (e.g. quantity, mass and type) of each material multiplied by an emission factor of a recognised source:

$$\text{Emissions (tCO}_2\text{e)} = \text{rate of activity (unit)} \times \text{emission factor (tCO}_2\text{e/unit)}$$

The Moata carbon portal, a Mott MacDonald tool for modelling the embodied and operational carbon of assets, was used to conduct the calculation for construction materials (A1 to A3 in K.5.1) emissions. Data on the type and quantity of materials, and estimated losses in operation was provided by Mott MacDonald design teams.

For technologies with limited data availability, a qualitative assessment has been conducted.

⁹⁰ The British Standards Institution (2016), *PAS 2080: 2016. Carbon Management in Infrastructure*. Available at: https://media.a55j14j15-publicinquiry.co.uk/uploads/2021/08/19124926/4.01.46-PAS_2080_Carbon_Management_In_Infrastructure-7.pdf [Accessed 12/12/2022]

K.4.3 GHG Valuations

The assessment utilises the BEIS, Greenbook Toolkit for Valuing Changes in Greenhouse Gas Emissions⁹¹ to provide a monetary comparison of the total emissions of technologies that are assessed quantitatively. The price assumption is based on the central scenario. It should be noted that other comparators should also be considered alongside the monetary cost estimates to provide a more holistic view of the carbon impact.

K.5 Assumptions

The following assumptions have been used in our assessment for each life cycle stage.

K.5.1 A1-A3 – Construction Materials

When there are no perfect matches between the material and emission factor, the following assumptions have been made to provide an estimate:

Overhead lines:

- Concrete is assumed to be of strength RC 35/45.
- Conventional lattice tower is assumed to be world average steel.
- Conductor aluminium alloy and optical ground wire (OPGW) aluminium alloy are assumed as general European aluminium mix.
- OPGW steel is assumed as world average steel wire rod.
- High strength hybrid composite core (carbon-glass fibre) for reconductoring is assumed as glass fibre.
- Composite insulator set and glass insulator discs are excluded in the assessment due to data availability.

Direct buried and in tunnel cables:

- Copper conductor for direct buried cables is assumed as virgin European copper tube and sheet.
- Polyethylene (PE) cable components are assumed to be general polyethylene.
- XLPE insulation component is assumed as high-density polyethylene (HDPE) resin.
- Thermally stable cable surround for direct buried cables is assumed as general virgin mix of land won and marine aggregate and sand.

Not all material components are included within the calculation due to data availability. The list of components included in the assessment are respectively outlined under each technology discussion section.

K.5.2 A4 - Transport of Materials to Site

- Assumed travelled distance of materials have been based on the RICS guidance.
- It is assumed that all materials are transported using the BEIS GHG emission factor for an average heavy goods vehicle (HGV), average laden.
- It is assumed that all concrete and aggregate are delivered locally (50 km). Specific electrical components, such as cables, are assumed to be European manufactured (transport distance

⁹¹ BEIS (2022). Valuation of energy use and greenhouse gas emissions for appraisal. Available at: <https://www.gov.uk/government/publications/valuation-of-energy-use-and-greenhouse-gas-emissions-for-appraisal> [Accessed 27/02/2023]

of 1,500 km). For metals that are not part of any specific electrical components, such as steel towers, national sourcing (300 km) is assumed.

K.5.3 A5 – Construction-related Activities

- For overhead lines, an emission factor for placing of reinforced concrete of thickness exceeding 500 mm is used to estimate the carbon from construction. Construction-related carbon from other materials have been excluded from the assessment.
- For direct buried cables, 1,250 mm depth of earth excavation is assumed and its carbon emissions is assessed using an emission factor for general excavation (1,000-2,000 mm depth). Filling of thermally stable cable surround filling is assumed to be 900 mm depth and its carbon emissions is calculated using an emission factor for imported rock filling (500 mm depth). Native soil filling is assumed to be approximately 350 mm depth and an emission factor for general excavated topsoil filling (500 mm depth) is used to assess its carbon emissions.

K.5.4 B1-B8 – Operation and Maintenance

- All technologies are assumed to have a useful lifespan of 40 years.
- Loss calculations are explained in Appendix I. Losses, and assume the actual load of onshore circuits being 34% rated power, with offshore circuits being assessed at 100% rated power (see Appendix C for further explanation).
- Given power factor varies over a 24-hour period, an estimate of 0.95 is considered in this calculation.
- An emission factor for UK transmission loss from a credible source is not available at the time of this analysis being conducted. An emission factor for UK electricity transmission and distribution combined (from the BEIS 2022 Greenhouse Gas Reporting: Conversion Factors⁹²) is used instead to assess the carbon emissions from losses. It is assumed that distribution contributes more losses than transmission⁹³. As losses in distribution systems are known to be higher this will over-estimate the contribution from transmission systems.
- The decarbonisation of the grid will impact operational emissions over the lifetime of the transmission technologies. If the UK Government's decarbonisation target (see K.2.2) is achieved, emissions associated with the grid will gradually reduce over time. To reflect the reduction over time, a reduction rate has been applied to the BEIS 2022 transmission and distribution emissions factor over the 40-year period. The percentage of reduction is based on the BEIS consumption-based emissions factors from 2023 to 2063^{94,95}.
- This assessment incorporates a sensitivity analysis to reflect the whole life emissions if decarbonisation is not accounted for. The 2022 emissions factor is applied to assess carbon across the 40-year period. This results in a conservative estimate, where the emission

⁹² BEIS (2022), *Government conversion factors for company reporting of greenhouse gas emissions*. Available at: <https://www.gov.uk/government/collections/government-conversion-factors-for-company-reporting> [Accessed 23/11/2022]

⁹³ National Grid ESO (2019). *Transmission Losses*. Available at: <https://www.nationalgrideso.com/electricity-transmission/document/144711/download#:~:text=On%20the%20Transmission%20network%2C%20the,lost%20over%20the%20distribution%20networks2.> [Accessed 12/12/2022]

⁹⁴ The consumption-based electricity EFs (kgCO₂e/kWh) is for measuring emissions per unit of final energy demand. BEIS has published annual EFs to 2100. There are three separate EFs for domestic, commercial/public sector, industrial consumption respectively. The discount rate applied in this study is based on their average% of reduction over time.

⁹⁵ BEIS. *Valuation of energy use and greenhouse gas emissions for appraisal*. Available at <https://www.gov.uk/government/publications/valuation-of-energy-use-and-greenhouse-gas-emissions-for-appraisal> [Accessed 24/02/2023]

factors are assumed to be the same over the lifetime of the technologies. The values are presented in brackets along with the calculations that account for decarbonisation.

K.5.5 C1-C4 – End of Life

- This stage has been excluded from this assessment due to lack of sufficient data.

K.5.6 D – Reuse Recovery Recycling Potential

- This stage has been excluded in this assessment due to data availability. However, general assumptions are made that buried materials would be harder to recover than those that are above ground.

K.6 Discussion

K.6.1 Quantitative Assessment

The following technologies have been assessed using a quantitative carbon assessment:

- 400 kV overhead lines.
- Reconductoring of existing overhead lines.
- 400 kV underground cable - direct buried.

The assessment also compares the operational carbon in relation to the level of power transmitted by each technology based on a 15 km length scenario. In addition, a 700 km, 765 kV a.c. 8 GW single circuit OHL scenario will also be assessed. This last scenario will be illustrated in a separate section due to the difference in asset scale with the other technologies, making a direct comparison flawed. Values on the total energy transmitted are based on Appendix I. Losses, and the comparison is presented in tCO_{2e}/MWkm format.

All figures in the following discussion have been rounded to nearest 10 tonnes. The carbon comparison of technologies is summarised in Table K.4. As outlined in Section K.5.4, the values that derive from the sensitivity analysis (assuming no decarbonisation over 40 years) are presented in brackets.

K.6.1.1 400 kV Overhead Lines (15 km)

The assessment estimated the embodied carbon emissions from the main components of the technology: conventional steel towers, conductor aluminium alloy, OPGW aluminium alloy, OPGW steel, and concrete. A high-level estimation of the emissions associated with transmission losses over a 40-year lifespan was also considered. The estimated carbon emissions derive from the following low, medium, and high all aluminium alloy conductor (AAAC) cases are shown in Table K.1.

Table K.1: Estimated carbon of 400 kV overhead lines

Scenario (15 km, 40-year period)	Embodied carbon emissions (tCO _{2e})	Operational carbon emissions (tCO _{2e})	Operational carbon per MWkm (tCO _{2e} /MWkm)	Total carbon emissions (tCO _{2e})
Case 1: Low (2x570 mm ² AAAC SORBUS per phase)	4,050	840 (5,270)	20 (100)	4,890 (9,310)
Case 2: Medium (2x850 mm ² AAAC REDWOOD per phase)	5,630	2,400 (15,070)	20 (140)	8,030 (20,700)

Scenario (15 km, 40-year period)	Embodied carbon emissions (tCO ₂ e)	Operational carbon emissions (tCO ₂ e)	Operational carbon per MWkm (tCO ₂ e/MWkm)	Total carbon emissions (tCO ₂ e)
Case 3: High (3x700 mm ² AAAC ARAUCARIA per phase)	7,830	4,370 (27,440)	30 (170)	12,200 (35,270)
Average	5,830	2,540 (15,920)	20 (140)	8,370 (21,760)

Values that derive from the sensitivity analysis (assume no decarbonisation over 40 years) are presented in brackets.

The average total emissions over a 40-year period of the three scenarios is 8,370 (21,750) tCO₂e for a 15 km scenario.

Construction materials (A1-A3) and transport of materials to site (A4) emissions account for 68% (26%) and 15% (0.6%) of total carbon for a 15 km OHL. Within construction materials, more than half (58%) comes from the conductor aluminium alloy. Conventional steel towers are estimated to cover one-third (35%) of construction materials carbon.

Transmission losses in operation are estimated to be 2,540 (15,920) tCO₂e over a 40-year period, accounting for 30% (73%) of total carbon. The average annual energy loss of the three cases is 22,500 MWh (double circuit).

Construction-related activities (A5) carbon (placing of reinforced concrete) accounts for only 0.05% (0.02%) of total carbon emissions over a 40-year period.

K.6.1.2 Reconductoring of Existing Overhead Lines

Table K.2: Estimated carbon of reconductoring of existing overhead lines

Scenario (15 km, 40-year period)	Embodied carbon emissions (tCO ₂ e)	Operational carbon emissions (tCO ₂ e)	Operational carbon per MWkm (tCO ₂ e/MWkm)	Total carbon emissions (tCO ₂ e)
Reconductoring of existing overhead lines	1,600	4,360 (27,410)	10 (60)	5,960 (29,010)

Values that derive from the sensitivity analysis (assume no decarbonisation over 40 years) are presented in brackets.

Compared to conventional conductors, High Temperature Low Sag Conductors (HTLS) provide higher thermal capabilities through additional materials to the usual aluminium, aluminium alloy and steel. The calculation of carbon for this technology is based on the case of twin aluminium conductor composite core (ACCC) Warwick. The main material components considered include conventional steel tower, conductor aluminium alloy, and composite core (carbon fibre). Carbon from construction is not considered in this assessment due to data limitations.

The estimated embodied carbon is 1,600 tCO₂e for a 15 km scenario. The majority of the total emissions (79%) comes from the embodied carbon of the carbon fibre conductor.

Operational carbon at 100% loading conditions is estimated to be 4,360 (27,410) tCO₂e over a 40-year period, accounting for 73% (94%) of total carbon.

K.6.1.3 400 kV Underground Cable - Direct Buried

Table K.3: Estimated carbon of 400 kV underground cable - direct buried

Scenario (15 km, 40-year period)	Embodied carbon emissions (tCO ₂ e)	Operational carbon emissions (tCO ₂ e)	Operational carbon per MWkm (tCO ₂ e/MWkm)	Total carbon emissions (tCO ₂ e)
400 kV underground cable - direct buried (low rating, double circuit)	4,010	640 (4,030)	10 (80)	4,660 (8,040)

Values that derive from the sensitivity analysis (assume no decarbonisation over 40 years) are presented in brackets.

The calculation is based on the case of 15 km of cable (low rating, double circuit). Construction materials (A1-A3) carbon calculation considered the following components: cable (copper conductor, PE shield, XLPE insulation, PE screen, PE water blocking, aluminium sheath, and PE jacket) and thermally stable cable surround. Estimation of carbon from construction is based on excavation and filling activities.

The estimated embodied carbon is 4,010 tCO₂e. Operational carbon only accounts for loss from the cable itself and is estimated to be 640 (4,030) tCO₂e over a 40-year period. This results in a total carbon content of 4,660 (8,040) tCO₂e.

In terms of carbon hotspots, the majority of construction materials (A1-A3) carbon (69%) comes from the copper conductor, with the remaining generally consists of XLPE insulation (10%) and aluminium sheath (11%).

Construction-related activities (A5) carbon (excavation activities) accounts for 2% (1%) of the total carbon calculated.

K.6.1.4 Carbon Comparison of Technologies

Table K.4: Quantitative carbon comparison of technologies

Technology (40-year period)	Embodied carbon (tCO ₂ e)	Operational carbon (tCO ₂ e)	Operational carbon per MWkm (tCO ₂ e/MWkm)	Valuation of total emissions (£)	Embodied carbon per km (tCO ₂ e)	Operational carbon per km (tCO ₂ e)	Total carbon emissions per km (tCO ₂ e)
400 kV overhead line (15 km)	5,830	2,540 (15,920)	20 (140)	2,110,160 (na)	390	170 (1,060)	560 (1,450)
Reconductoring of existing overhead lines (15 km)	1,600	4,360 (27,410)	10 (60)	1,503,650 (na)	60	290 (1,830)	400 (1,890)
400 kV direct buried cable (low rating, double circuit) (15 km)	4,010	640 (4,030)	10 (80)	1,173,640 (na)	270	40 (270)	310 (540)

Note: Values that derive from the sensitivity analysis (assume no decarbonisation over 40 years) are presented in brackets.

Assuming that the power system decarbonises by 2035, the carbon emissions associated with transmission losses reduce significantly over time, from initially generating the majority of the total carbon emissions associated with OHL (>70%) in 2023, to almost zero emissions.

Reconductoring has a significantly lower embodied carbon footprint as it only accounts for the materials additional to an existing overhead line. The operational carbon is higher than an average 400 kV OHL.

The carbon assessment of underground technologies only accounts for the cable itself including its manufacturing and installation process (including excavations etc.). Therefore, while direct buried cables have the lowest embodied and operational carbon according to the calculation, other factors should be considered. For example, the material recovery potential of underground cables will be lower than for an OHL. The civil works, equipment and fuel use from machineries are also more carbon intensive than an OHL equivalent, which may differentiate the overall whole life carbon of the two technologies.

When taking into consideration the level of power transmitted and the length of the circuit, the operational carbon per MW- km over a 40-year period ranges from 10 (60) to 20 (140) tCO₂e/MWkm for the technologies with a 15 km scenario.

The monetised valuation of total emissions ranges from 1.2 to 2.1 million GBD when taking into account the UK Green Book assumptions. No valuations could be conducted for the sensitivity analysis due to an absence of relevant price assumptions.

These calculations are based on a high-level estimation of material composition and loss assumption and therefore actual carbon emission values of each technology will vary on a project-by-project basis.

K.6.1.5 765 kV AC 8GW Double Circuit Overhead Line

Table K.5: Estimated carbon of 765 kV AC single circuit overhead line

Scenario (700 km, 40-year period)	Embodied carbon emissions (tCO ₂ e)	Operational carbon emissions (tCO ₂ e)	Operational carbon per MW-km (tCO ₂ e/MW- km)	Total carbon emissions (tCO ₂ e)	Valuation of total emissions (£)	Embodied carbon per km (tCO ₂ e)	Operational carbon per km (tCO ₂ e)	Total carbon emissions per km (tCO ₂ e)
765 kV AC single circuit OHL	243,630	145,620 (914,431)	37,450 (235,170)	389,240 (1,158,060)	42,474,384 (na)	348	208 (1,306)	556 (1,654)

Values that derive from the sensitivity analysis (assume no decarbonisation over 40 years) are presented in brackets.

As previously stated, with the 765 kV AC single circuit OHL covering a longer distance, over 45 times as much the other scenarios, there are far more assets involved in its construction and operation. Thus, the carbon emissions for this technology will be significantly higher than the previous cases.

The materials used in the 765 kV OHL are assumed to be identical to the materials used in a 400 kV OHL, apart from insulators, arcing devices and fittings which are designed to manage larger electrical stress derived from these voltage levels. The estimation is based on the case of 765 kV lines with the conductor configuration of aluminium conductor steel reinforced (ACSR) type 400/51. The main material components considered include conventional steel towers, conductor aluminium alloy, conductor steel, OPGW aluminium alloy, OPGW steel, and concrete. A high-level estimation of carbon from construction is also considered.

The total carbon for a 700 km, 8 GW capacity scenario is estimated to 389,240 (1,158,060) tCO_{2e}. The estimated embodied carbon is 243,630 tCO_{2e}. The operational carbon over a 40-year period is around 145,620 (914,431) tCO_{2e}, accounting for 37% (79%) of the total carbon.

Construction materials (A1-A3) accounts for the majority of the remaining 63% (21%) total carbon over a 40-year period. The majority of the construction materials carbon content is split between the conductor aluminium alloy (41%) and conventional steel tower (32%).

Construction-related activities (A5) carbon (placing of reinforced concrete) only accounts for 0.05% (0.02%) of total carbon over a 40-year period. However, it is likely that other types of construction plant will be required during construction, resulting in a larger carbon impact.

K.6.2 Qualitative Assessment

For the following technologies we have undertaken a high-level qualitative assessment due to limited data availability:

- Gas-insulated Line (GIL) (direct buried and in tunnel);
- Overhead line using T-Pylons;
- 400 kV underground cable - in tunnel (15 km);
- a.c. submarine cable (180 km);
- Superconducting Cables (3 km);
- HVDC system;
- Series Compensation (quad boosters, Thyristor Controlled Series Capacitor, Static Series Synchronous Compensator) .

K.6.2.1 GIL (Direct Buried and in Tunnel)

GIL are assumed to be two pipes per phase, with each pipe consisting of materials such as aluminium used for the conductor and tube (coated if directly buried), cast resin post insulators, and insulating gas (20% SF₆ and 80% N₂). The use of carbon intensive materials (e.g. aluminium) would increase the embodied carbon of the technology.

High voltage GIL has a lower power loss percentage than OHL and underground cables⁹⁶, which in return reduces the carbon impact due to transmission losses⁹⁷.

The use of SF₆, a potent GHG, brings a risk of a significant impact on its carbon impact during operation. However, estimated SF₆ leakage rates amount to only 0.1% annually and thus, during normal operations, are not a significant contributory factor. It should be acknowledged that there is the potential use of SF₆ alternatives, with SF₆-free GIL expected to reach technology readiness level (TRL) 9 within the next decade⁹⁸.

Similar to OHL and underground cables, operational carbon is expected to account for the majority of the carbon over a 40-year period.

⁹⁶ Khan, Danish & Rafiq, Muhammad & Syed, Furqan & Khan, Idris & Abbas, Farukh. (2014). *Comparison of transmission losses and voltage drops of GIL (Gas-insulated transmission line) and overhead transmission lines (230KV, 345KV, 500KV, 765KV, 1100KV)*. 10.1109/EPEPEMC.2014.6980666. [Accessed 12/12/2022]

⁹⁷ Elnaddab, K., Haddad, A., & Griffiths, H. (2012). The transmission characteristics of gas-insulated lines (GIL) over long distance. *2012 47th International Universities Power Engineering Conference (UPEC)*, 1-5. [Accessed 12/12/2022]

⁹⁸ ENTSOE (n.a.), *Gas-insulated lines (GIL) AC*. Available at: <https://www.entsoe.eu/Technopedia/techsheets/gas-insulated-lines-gil-ac> [Accessed 12/12/2022]

K.6.2.2 Overhead Line Using T-Pylons

T-pylons are made of painted hot-dip galvanised steel⁹⁹. Despite its overall smaller physical appearance, the mass of a T-pylon is significantly higher than lattice steel equivalent (a difference between 76 tonnes and 29 tonnes for the Hinkley Connection Project example)¹⁰⁰. The assessment in K.6.1.1 estimated that lattice towers account for 30-37% of total embodied carbon for a 15 km scenario. T-Pylons, with the mass that is more than two times higher than lattice steel equivalent, are estimated to result in a higher embodied carbon, assuming that the number of towers required and configurations of other OHL components are similar to a lattice steel equivalent.

Alternative towers with the same conductor type are expected to have negligible effects in the calculation of losses-related carbon for OHL.

Construction-related carbon is expected to differ from conventional lattice towers. On-site installation is expected to be shorter due to its modular design.

T-pylons are also expected to require less maintenance and replacements than conventional lattice towers. This should reduce the carbon related to fuel consumption during inspection and maintenance activities.

K.6.2.3 400 kV Underground Cable - in Tunnel (15 km)

The 400 kV cable in tunnel has similar configuration to the 400 kV direct buried cable, therefore its embodied carbon of the cable component and operational losses are expected to be similar. However, the quantities of concrete needed for cables in a tunnel will be significantly higher than direct buried cables. Carbon derived from the transport of materials and construction processes will be significantly higher due to the civil work complexity (e.g. excavation) associated with tunnelling. It is estimated that tunnelling equipment (e.g. Lovat tunnel boring machines (TBMs) electricity use) will be a major source of carbon emissions aside from transmission losses¹⁰¹.

K.6.2.4 a.c. Submarine Cable (180 km)

HVAC XLPE submarine cable consists of a conductor (either aluminium or copper), XLPE insulation, lead sheath screen, semiconductor core sheath, galvanised steel wires for armouring, and outer serving made of bitumen and polypropylene yarn¹⁰². It is estimated that the embodied carbon footprint would be similar to an underground cable due to their similarities in key components. However, the actual level of embodied carbon will depend on its specific configuration (three cores or single core).

Submarine cable of 220 kV is estimated to have similar transmission losses to an OHL¹⁰³. Cables with an aluminium conductor will have higher embodied and operational carbon than a copper type due to higher transmission losses.

⁹⁹ Bystrup (n.a.), *The T-Pylon*. Available at: <https://www.powerpylons.com/t-ylon> [Accessed 12/12/2022]

¹⁰⁰ Kanaris, S. (2022), *Future of Energy. T-pylons signal a route to less intrusive infrastructure*. New Civil Engineer. Available at: <https://www.newcivilengineer.com/the-future-of/future-of-energy-t-pylons-signal-a-route-to-less-intrusive-infrastructure-30-05-2022/?tkn=1> [Accessed 12/12/2022]

¹⁰¹ Harrison, GP, Maclean, EJ, Karamanlis, S & Ochoa, LF (2010), 'Life cycle assessment of the transmission network in Great Britain', *Energy Policy*, vol. 38, no. 7, pp. 3622-3631. Available at: <https://doi.org/10.1016/j.enpol.2010.02.039> [Accessed 21/11/2022]

¹⁰² ENTSO-E (n.a.) *HVAC XLPE (Cross-linked Polyethylene)*. Available at: <https://www.entsoe.eu/Technopedia/techsheets/hvac-xlpe-cross-linked-polyethylene> [Accessed 21/11/2022]

¹⁰³ Antunes et al. (2018). Limitations of HVAC Offshore Cables in Large Scale Offshore Wind Farm Applications. *Astes*. Available at: https://www.astesj.com/publications/ASTESJ_030217.pdf [Accessed 20/12/2022]

Submarine cable is usually buried in the seabed or protected by rocks and the duration and equipment needed for construction and installation are expected to generate higher carbon emissions in comparison to OHL and underground cables. Equipment fuel use during the construction process will likely be a main source of carbon aside from losses in operation.

K.6.2.5 Series Compensation (Quad Boosters, Thyristor Controlled Series Capacitor, Static Series Synchronous Compensator)

Quad Boosters have a similar configuration as a conventional transformer, which comprises a steel tank with an iron core and copper windings interior. The tank is filled with transformer oil and sited on a concrete foundation¹⁰⁴. In comparison, a Static Series Synchronous Compensator consists of power electronics devices that are sited on steel frames mounted on a much smaller concrete foundation. The configuration of Thyristor Controlled Series Capacitor is similar to the Static Series Synchronous Compensator, with the exception of its devices and their foundations having a larger profile. Both Static Series Synchronous Compensator and Thyristor Controlled Series Capacitor do not require to be filled with oil.

Based on their configurations, Static Series Synchronous Compensators are expected to have the smallest embodied carbon out of the three, followed by Thyristor Controlled Series Capacitor. Quad boosters are assumed to have the highest carbon content given their larger mass and the need for transformer oil.

All three technologies involve above ground constructions and therefore the carbon emissions associated with the transport of materials and construction will not be as significant as those that are underground. The main carbon hotspot of these technologies is expected to derive from the carbon intensive materials (e.g. metal, oil).

This assessment does not evaluate the operational carbon due to limited data availability. It should be noted that series compensation does not reduce line losses, and there will be losses contributed by the equipment themselves. Loss from the equipment can be minimised by switching them off when the nearby network circuits are not at thermal capacity.

K.6.2.6 HVDC System (Point-to-point and Multi-terminal)

This section assesses the following configurations of a HVDC system:

- HVDC VSC, either bi-pole (2 GW, 525 kV) or symmetrical monopole (500 MW and 1 GW, 320 kV). These configurations are considered using a submarine cable to either link two onshore converter stations, or one onshore and one offshore converter station.
- HVDC LCC system using 800 kV overhead line to provide 8 GW capacity.
- HVDC VSC bi-pole, using 525 kV underground cable to provide a 2 GW point to point link onshore.
- Multi-terminal HVDC system with two onshore and one offshore converter stations, and associated cable circuits.

HVDC has lower transmission losses than HVAC over longer distances. HVDC transmission requires converter stations at each end of the link. An industry recognised benchmark is to assume 1% full load losses per converter station for VSC applications, or 0.8% for LCC configurations (refer to Appendix I.).

An 8 GW HVDC 800 kV OHL has a similar configuration and clearance of a single circuit 765 kV AC OHL and therefore is estimated to have a comparable carbon impact. For underground cables, the cable aspect of an onshore HVDC system of 2 GW, 525 kV is estimated to have a

¹⁰⁴ ENTSO-E (n.a.), Phase Shifting Transformers. Available at:
<https://www.entsoe.eu/Technopedia/techsheets/phase-shifting-transformers> [Accessed 12/12/2022]

comparable carbon impact to a 400 kV underground cable due to its similar line architecture. However, the addition of the converter stations at each end will likely increase the operational carbon due to transmission losses.

The main components of a VSC comprise a capacitor (conductive metal, e.g. aluminium), diode (semiconductor), rectifier (semiconductor) and resistor (metal alloy, metal oxide, and carbon film). Metal components are expected to account for the majority of the construction materials (A1-A3) carbon.

The physical footprint of a VSC station is smaller than a LCC station. It does not require reactive compensation equipment with a typical footprint being approximately 120 x 60 x 22 m¹⁰⁵. Some components within a converter station are expected to have a lower lifespan and would need replacement after a certain period, and other items could require refurbishment. This will increase the embodied and maintenance carbon over a 40-year lifespan¹⁰⁶.

For a point-to-point VSC HVDC system, conversion loss at full load is around 2% of rated capacity for the two converter stations combined (cable connection excluded). A multi-terminal HVDC system can consist of more than two converters connected within the network¹⁰⁷, with most applications under consideration currently envisaging three terminals. It is estimated that conversion losses from the three converter stations, similar to a point-to-point system, will account for a significant proportion of the whole life carbon. The overall embodied carbon is estimated to be higher than a point-to-point system due to the additional converter station. A comparison of operational carbon between the point-to-point and multi-terminal systems in relation to their total energy transmitted will be needed to provide a better understanding on their overall carbon impact.

K.6.2.7 Superconducting Cables

The main materials of a superconducting cable comprise superconductors made of rare earth materials (commonly available in strontium calcium copper oxygen (BSCCO) and yttrium barium copper oxide (YBCO)), dielectric high voltage insulating material, liquid nitrogen, cooling system, and polyethylene sheath¹⁰⁸. Its configuration complexity and the industrial process involved in its rare earth material components are expected to result in higher construction materials (A1-A3) carbon.

Superconducting cables have almost no resistance-based power losses, making their operational carbon significantly lower than other conventional cables. This drastically reduces its total carbon impact over a 40-year period. However, consideration must be given to the liquid nitrogen-based cooling system which must be in continuous operation. The production (compression and fractional air distillation) and transportation process of liquid nitrogen are energy intensive. Liquid nitrogen use could produce a significant amount of waste due to liquid

¹⁰⁵ National Grid (n.a.) High Voltage Direct Current Electricity – technical information. *National Grid*. Available at: <https://www.nationalgrid.com/sites/default/files/documents/13784-High%20Voltage%20Direct%20Current%20Electricity%20%E2%80%93%20technical%20information.pdf> [Accessed 20/12/2022]

¹⁰⁶ National Grid (n.a.) High Voltage Direct Current Electricity – technical information. *National Grid*. Available at: <https://www.nationalgrid.com/sites/default/files/documents/13784-High%20Voltage%20Direct%20Current%20Electricity%20%E2%80%93%20technical%20information.pdf> [Accessed 20/12/2022]

¹⁰⁷ Liang et al. (2012). A multi-terminal HVDC transmission system for offshore wind farms with induction generators, *International Journal of Electrical Power & Energy Systems*, Volume 43, Issue 1, 2012, Pages 54-62, ISSN 0142-0615. Available at: <https://doi.org/10.1016/j.ijepes.2012.04.063>. [Accessed 20/12/2022]

¹⁰⁸ ENTSO-E (n.a.), High Temperature Superconductor (HTS) Cables. Available at: <https://www.entsoe.eu/Technopedia/techsheets/high-temperature-superconductor-hts-cables> [Accessed 20/12/2022]

nitrogen being boiled off when transferred¹⁰⁹. Operation of this system also requires the consumption of electricity and will therefore result in carbon emissions.

K.7 Conclusions

This report provides a high-level quantitative and qualitative carbon assessment of transmission technologies. The following key findings can be summarised to guide future carbon assessment and comparison of transmission technologies:

- Carbon intensive metals, such as aluminium alloy and copper, within conductors will likely generate a significant portion of construction materials (A1-A3) carbon. Carbon will vary based on the project scale and specific configuration of the technology.
- Offshore installation and tunnel mounting are expected to have higher construction-related activities carbon (A5) than direct buried and above ground technologies. The amount of carbon varies based on the location, construction duration, transport distance of materials, and the fuel use of construction equipment.
- When assessing over a useful lifespan, carbon related to transmission losses reduces significantly over time if the grid decarbonises by 2035.
- It should be noted that due to a scarcity of data on the carbon footprint of transmission technologies, various assumptions and exclusions related to material components, construction, and operation have to be made in this assessment. The actual carbon value of technologies will vary on a project-by-project basis and should be assessed individually when more detailed design plans and data are available.
- The data limitations within this report highlight that carbon impact of transmission technologies is currently not a mature area of research. However, as highlighted in previous sections, Ofgem has now put regulations in place for transmission owners and operators to report their carbon emissions, and these companies are now developing carbon reduction targets and carbon quantification tools. This will likely mean that the carbon impact of transmission technologies will become better understood in the near future.

¹⁰⁹ Cytiva (2020). Going liquid nitrogen-free for low-impact cryopreservation. Available at: <https://cdn.cytivalifesciences.com/api/public/content/digi-31119-pdf> [Accessed 20/12/2022]

L. Bibliography

The following list of reference sources were consulted as part of the production of this document:

General Documents

“Electricity Transmission Costing Study: An Independent Report Endorsed by the Institution of Engineering & Technology,” Parsons Brinckerhoff, Jan. 2012. Available: <https://www.theiet.org/impact-society/factfiles/energy-factfiles/energy-generation-and-policy/electricity-transmission-costing/>

“Pathway to 2030- Holistic Network Design”, National Grid ESO, Jul. 2022. Available: <https://www.nationalgrideso.com/future-energy/the-pathway-2030-holistic-network-design>

“Electricity Ten Year Statement”, National Grid ESO, Nov. 2021. Accessible: <https://www.nationalgrideso.com/research-publications/etys>

“British Energy Security Strategy”, HM Government, Apr. 2022. Accessible: <https://www.gov.uk/government/publications/british-energy-security-strategy/british-energy-security-strategy>

“National Electricity Transmission System Security and Quality of Supply Standard”, National Grid ESO, ver. 2.5, Apr. 2021. Accessible: <https://www.nationalgrideso.com/industry-information/codes/security-and-quality-supply-standards/code-documents>

“Technology Readiness Levels”, ENTSO-E. Accessible: <https://www.entsoe.eu/Technopedia/trls/>

Overhead Lines

“International Practice in the Approach to and Levels of Compensation of Property Owners in Proximity to High-Voltage Transmission Lines”, KHSK Economic Consultants, Mar. 2018. Accessible: <https://assets.gov.ie/123265/18d94981-358b-462b-ae20-54a82ef24d21.pdf>

“Project Map - Dunoon - Project Documents”, SSEN, Jan. 2023. Available: <https://www.ssen-transmission.co.uk/projects/project-map/dunoon/>

“The RICA Project: WP1 - Literature Review”, National Grid, Apr. 2021. Accessible: <https://www.nationalgrid.com/electricity-transmission/document/137836/download>

“Measurement of Power Line Sagging Using Sensor Data of a Power Line Inspection Robot”, IEEE, Jun. 8 2020. Accessible: <https://ieeexplore.ieee.org/stamp/stamp.jsp?arnumber=9103065>

“Steel Power Pole Products”, Steel Power Pole, 2023. Available: https://www.steelpowerpole.com/supplier-steel_power_pole-202666.html

“Dorset Project Scoping Report”, National Grid Electricity Transmission, 2016. Available at: <https://dorset.nationalgrid.co.uk/documents/dorset-aonb-overhead-line-scoping-report/>

“National Grid Creyke Beck substation”, Geograph, 2015. Accessible: <https://www.geograph.org.uk/photo/4448537>

“Insulators for OHL 35 kV. - 750 kV”, ITG, 2013. Accessible: <http://www.itg.ge/insulators.html>

“Suspension Insulator”, Orient Tec Insulators, 2020. Accessible: www.powerinsulator.com

“HexaCore Optical Ground Wire (OPGW)”, AFL, 2022. Available: <https://www.aflglobal.com/emea/Products/Fiber-Optic-Cable/Aerial/OPGW/HexaCore-OPGW>

“GAP+”, Lamifil, 2023. Available: <https://lamifil.be/overhead-conductors/gap/>

“The improved GAP conductor”, Lamifil, May. 2011. Available: https://lamifil.be/wp-content/uploads/2011/05/GZTACSR_NG1.pdf

“Protecting Grid Integrity- More amps, more confidence”, 3m, 2014. Available: <https://multimedia.3m.com/mws/media/4782700/3m-accr-technical-summary-english-units.pdf>

“Welcome to the RICA Project”, National Grid, 2020. Available: <https://www.nationalgrid.com/electricity-transmission/innovation/rica>

“Western Alberta Transmission Line”, Rokstad Power, 2022. Available: <https://rokstadpower.com/portfolio/watl/>

Underground Cables

“XLPE Insulation Power Cable, EHV Cable, HV Cable”, Focus Technology, 2023. Available: <https://lonheo.en.made-in-china.com/product/cKDXBiYbLjVv/China-XLPE-Insulation-Power-Cable-EHV-Cable-HV-Cable.html>

“SEB CD980S Extendable Cable Drum Trailer”, Thorne & Derrick International, 2023. Available: <https://www.powerandcables.com/seb-cd980s-extendable-cable-drum-trailer/>

“Fortum Wind Park, Finland”, NKT, 2023. Available: <https://www.nkt.com/references/fortum-wind-park-finland>
<https://www.nationalgrid.com/electricity-transmission/document/140351/download>

<https://www.powerandcables.com/cable-grips/>

[https://www.sserenewables.com/news-and-views/2021/08/seagreen-onshore-project-get-cable-pulling-underway-across-19 km -route-through-angus-scotland/](https://www.sserenewables.com/news-and-views/2021/08/seagreen-onshore-project-get-cable-pulling-underway-across-19-km-route-through-angus-scotland/)

<https://dca-europe.org/hdd-technique?lang=en>

Submarine Cables

“Effect of Sheath Plastic Deformation on Electric Field in Three Core Submarine Cables”, Semantic Scholar, Oct. 2018. Available: <https://www.semanticscholar.org/paper/Effect-of-Sheath-Plastic-Deformation-on-Electric-in-Hamdan-Pilgrim/d8a6900a7349ff-d5483fd-e9c678df-cf60b7349ab/figure/0>

“HVDC Mass Impregnated Cable Systems—a Well-Proven Concept”, Nexans, 2017. Available: https://www.nexans.com/dam/jcr:4e476fd-2-1b3a-495e-a76b-fbe0f5fe-491c/Nexans-article-HVDC-Mass-Impregnated-Cable_Systems-a_Well-Proven_Con.pdf

“Prysmian Group’s Leonardo da Vinci cables installation vessel wants YOU!”, Prysmian Group, 2017. Available: <https://www.prysmiangroup.com/en/insight/projects/prysmian-groups-leonardo-da-vinci-cables-installation-vessel-wants-you>

“CLV Nexans Aurora- The flagship of the Nexans fleet”, Nexans, 2017. Available: <https://www.nexans.com/en/business/power-generation-transmission/subsea-interconnectors/CLV-Nexans-Aurora.html>

“ST200 Series”, Global Marine, 2023. Available: <https://globalmarine.co.uk/vessels-trenching-assets/st200-2/>

“XT600 Trenching System”, Global Marine, 2023. Available: <https://globalmarine.co.uk/vessels-trenching-assets/xt600-trenching-system/>

Mamatsopoulos, V & Michailides, C & Theotokoglou, E.E., “An Analysis Tool for the Installation of Submarine Cables in an S-Lay Configuration Including “In and Out of Water” Cable Segments”, Journal of Marine Science and Engineering, 8. 48. Jan. 2020. Available: <https://doi.org/10.3390/jmse8010048>

“Prysmian To Further Expand Its Cable-Laying Vessel Fleet”, Prysmian Group, Nov. 2022. Available: <https://www.prysmiangroup.com/sites/default/files/corporate/media/downloads/pdf/press-releases/pr-new-vessel-2025-22-11-2022-eng.pdf>

“The Tyrrhenian Link: The Double Underwater Connection Between Sicily, Sardinia And The Italian Peninsula”, Terna, 2022. Available: <https://www.terna.it/en/projects/public-engagement/Tyrrhenian-link>

High Voltage Direct Current

Reprinted with permission from CIGRE, Offshore Generation Cable Connections, Technical Brochure 610, © 2015.

“HVDC Links in System Operations”, ENTSO-E. Dec. 2019. Available: https://eepublicdownloads.entsoe.eu/clean-documents/SOC%20documents/20191203_H_VDC%20links%20in%20system%20operations.pdf

“HVDC Transmission: Technology Review, Market Trends and Future Outlook”, Iberdrola Innovation and The University of Strathclyde, Available: <https://core.ac.uk/reader/210996200>

“NordLink”, Tennent, 2023. Available: <https://www.tennent.eu/projects/nordlink>

“DolWin1”, Hitachi Energy, 2023. Available: <https://www.hitachienergy.com/about-us/case-studies/dolwin1>

Losses

“Capturing key developments across the GB energy sector”, Cornwall Insight: Energy Spectrum, Issue 838, Jan. 2023

“NGET_A11.11 Transmission Loss Strategy”, National Grid, Dec. 2019. Available: <https://www.nationalgrid.com/electricity-transmission/document/132276/download>

“RIIO-2 Final Determinations – Finance Annex (REVISED)”, Ofgem, Feb. 2021. [Online]. Available: https://www.ofgem.gov.uk/sites/default/files/docs/2021/02/final_determinations_-_finance_annex_revised_002.pdf

Carbon

Harrison, GP, Maclean, EJ, Karamanlis, S & Ochoa, LF, “Life cycle assessment of the transmission network in Great Britain”, Energy Policy, vol. 38, no. 7, 2010, pp. 3622-3631. Available: <https://doi.org/10.1016/j.enpol.2010.02.039>

“Sustainability Statement 2016”, SSE, 2016. Available: https://www.ssen-transmission.co.uk/globalassets/documents/environmental-discretionary-reward-edr/4604-sse-transmission-sustainability-statement_2016_p_rinfriently_final-2.pdf

“Sulfur Hexafluoride Basics”, EPA, 2022. Available: <https://www.epa.gov/eps-partnership/sulfur-hexafluoride-sf6-basics>

"Green House Gas Protocol- Global Warming Potential Values", Adapted from the IPCC Fifth Assessment Report, 2016. Available: https://ghgprotocol.org/sites/default/files/ghgp/Global-Warming-Potential-Values%20%28Feb%2016%202016%29_1.pdf

"Energy network indicators", Ofgem, 2021. Available: <https://www.ofgem.gov.uk/energy-data-and-research/data-portal/energy-network-indicators>

"Sustainability First. ED2 Business Plans – Ofgem Call for Evidence. Annex 2 – DNO SF6 Strategies", Ofgem, Feb. 2016. Available: <https://www.ofgem.gov.uk/sites/default/files/2022-03/Sustainability%20First%20-%20RIO%20ED2%20BPs%20-%20Response%20to%20Ofgem%20-%20Annex%20-%20SF6%20STRATEGIES%20-%20080222final.pdf>

"Final UK greenhouse gas emissions national statistics: 1990 to 2020", BEIS, Jun. 2022. Available: <https://www.gov.uk/government/statistics/final-uk-greenhouse-gas-emissions-national-statistics-1990-to-2020>

"Government conversion factors for company reporting of greenhouse gas emissions", BEIS, Jun. 2022. Available: <https://www.gov.uk/government/collections/government-conversion-factors-for-company-reporting>

"RIIO-2 Environmental Reporting Guidance Version 1.0.2, Ofgem, Mar. 2021. Available: https://www.ofgem.gov.uk/sites/default/files/docs/2021/03/riio-2_environmental_reporting_guidance_v_1_final.pdf

"Guidance Document for PAS 2080", Construction Leadership Council, 2019. Available: https://www.constructionleadershipcouncil.co.uk/wp-content/uploads/2019/06/Guidance-Documents-for-PAS2080_Final.pdf

"SP Transmission Annual Environmental Report 2021/2022", SP Energy Networks, 2022. Available: https://www.spenergynetworks.co.uk/userfiles/file/39727_Transmission_Annual_Environmental_Report_Commitments_2021-2022final_online_version.pdf

"Powering change together- SSE PLC Sustainability Report 2022", SSE, 2022. Available: <https://www.sse.com/media/bgnpqj2x/sustainability-report-2022-v1.pdf>

"Supply Chain Sustainability School", National Grid, 2022 Available: <https://www.supplychainschool.co.uk/partners/national-grid/>

"Good progress but not fast enough", The Green Construction Board, Apr. 2021. Available: https://www.constructionleadershipcouncil.co.uk/wp-content/uploads/2021/04/Infrastructure-Carbon-Review-seven-years-on_March-2021.pdf

"Our 2021-2026 Environmental Action Plan", National Grid, 2021. Available: <https://www.nationalgrid.com/electricity-transmission/document/136551/download>

"SSEN Transmission Sustainability Report 2021/2022", SSEN, 2022. Available: <https://www.ssen-transmission.co.uk/globalassets/documents/sustainability-strategy/sustainability-report-2021-22.pdf>

"Whole Life Carbon Assessment for the Built Environment 1st Edition", RICS, Nov. 2017. Available: <https://www.rics.org/uk/upholding-professional-standards/sector-standards/building-surveying/whole-life-carbon-assessment-for-the-built-environment/>

"PAS 2080: 2016. Carbon Management in Infrastructure", The British Standards Institution, 2016. Available: https://media.a55j14j15-publicinquiry.co.uk/uploads/2021/08/19124926/4.01.46-PAS_2080_Carbon_Management_In_Infrastructure-7.pdf

"Going liquid nitrogen-free for low-impact cryopreservation", Cytiva, 2020. Available: [https://cdn.cytivalifesciences.com/api/public/content/digi-31119-pdf#:~:text=The%20carbon%20footprint%20of%20liquid,of%20liquid%20nitrogen%20\(3\)](https://cdn.cytivalifesciences.com/api/public/content/digi-31119-pdf#:~:text=The%20carbon%20footprint%20of%20liquid,of%20liquid%20nitrogen%20(3))

Environmental

"Guidelines on Best Environmental Practice in Cable Laying and Operation", OSPAR Commission, Feb. 2012. Available: https://www.gc.noaa.gov/documents/2017/12-02e_agreement_cables_guidelines.pdf

Alternative Technologies

"Series Compensation Systems", GE, 2022. Available: https://www.gegridsolutions.com/powerd/catalog/series_comp.htm

"PTR-0189 Power Transformers and Reactors Brochure", GE, Jun. 2019. Available: https://www.gegridsolutions.com/products/brochures/Power_Transformers/Power_Transformer_Range-Brochure-EN-2019-06-Grid-PTR-0189.pdf

"Gas-insulated Bus: Reliable, cost-effective long-distance power transmission", Avail Infrastructure Solutions, Sep. 2022. Available: https://www.availinfra.com/wp-content/uploads/2022/10/Avail_GasInsulated_BusSystems_BrochureSngl.pdf

"SF6 Gas-insulated Lines (GIL) Application Guide", Avail Infrastructure Solutions, Sep. 2022. Available: https://www.availinfra.com/wp-content/uploads/2022/10/Avail_SF6-GILines_GuideSngl.pdf

“High Voltage Products: Gas-insulated Transmission Line”, Hitachi Energy, 2021. Available:
<https://search.abb.com/library/Download.aspx?DocumentID=1HC0182640&LanguageCode=en&DocumentPartId=&Action=Launch>

M. Yazdani-Asrami, S. Seyyedbarzegar, A. Sadeghi, W. T. B. de Sousa, and D. Kottonau, “High temperature superconducting cables and their performance against short circuit faults: current development, challenges, solutions, and future trends”, *Superconductor Science and Technology*, vol. 35, no. 8, p. 083002, Jul. 2022. Available: <https://doi.org/10.1088/1361-6668/ac7ae2>

“Nexans Superconductors for Electricity Grids - White Paper 2022”, Nexans, 2022. Available:
<https://www.nexans.com/en/company/Innovation/superconducting-cables.html>

D. Doukas, “Superconducting Transmission Systems: Review, Classification and Technology Readiness Assessment”, *IEEE Transactions on Applied Superconductivity*, vol. 29, issue 5, Jan. 2019. Available:
<https://doi.org/10.1109/TASC.2019.2895395>

Mohammad Yazdani-Asrami, Alireza Sadeghi, Milind D. Atrey, “Selecting a cryogenic cooling system for superconducting machines: General considerations for electric machine designers and engineers”, *International Journal of Refrigeration*, vol. 140, 2022, Pages 70-81, ISSN 0140-7007. Available:
<https://doi.org/10.1016/j.ijrefrig.2022.05.003>

Xi Hua Zong, Yun Wu Han, Chong Qi Huang, “Introduction of 35-kV kilometer-scale high-temperature superconducting cable demonstration project in Shanghai”, *Superconductivity*, vol 2, 2022, 100008, ISSN 2772-8307. Available: <https://doi.org/10.1016/j.supcon.2022.100008>

Kanaris, S., “Future of Energy. T-pylons signal a route to less intrusive infrastructure”, *New Civil Engineer*, May. 2022. Available: <https://www.newcivilengineer.com/the-future-of/future-of-energy-t-pylons-signal-a-route-to-less-intrusive-infrastructure-30-05-2022/?tkn=1>

Ofgem HVDC Interconnector Project Assessments

“Decision on assessment of IFA, BritNed and Nemo Link’s pilot project and interim period cost recovery submissions under the Capacity Allocation and Congestion Management (CACM) Regulation,” Ofgem, Jan. 2021. Available:
<https://www.ofgem.gov.uk/publications/decision-assessment-ifa-britned-and-nemo-links-pilot-project-and-interim-period-cost-recovery-submissions-under-capacity-allocation-and-congestion-management-cacm-regulation>

“Decision on the Initial Project Assessment of the FAB Link, IFA2 and Viking Link interconnectors,” Ofgem, Jul. 2015. Available: <https://www.ofgem.gov.uk/publications/decision-initial-project-assessment-fab-link-ifa2-and-viking-link-interconnectors>

“Decision on the Initial Project Assessment of the Greenlink interconnector”, Ofgem, Sept. 2015. Available:
<https://www.ofgem.gov.uk/publications/decision-initial-project-assessment-greenlink-interconnector>

“Decision on the Initial Project Assessment of the GridLink, NeuConnect and NorthConnect interconnectors”, Ofgem, Jan. 2018. Available: <https://www.ofgem.gov.uk/publications/decision-initial-project-assessment-gridlink-neuconnect-and-northconnect-interconnectors>

“Final Project Assessment of the IFA2 interconnector to France”, Ofgem, Jul. 2018. Available:
<https://www.ofgem.gov.uk/publications/final-project-assessment-ifa2-interconnector-france>

“Cost assessment consultation for the proposed GB-Belgium interconnector, Nemo”, Apr. 2014. Available:
<https://www.ofgem.gov.uk/publications/cost-assessment-consultation-proposed-gb-belgium-interconnector-nemo>

“Decision on the Final Project Assessment of the NeuConnect interconnector to Germany”, Ofgem, Jul. 2022. Available: <https://www.ofgem.gov.uk/publications/decision-final-project-assessment-neuconnect-interconnector-germany>

“Decision on the Final Project Assessment of the Viking Link interconnector to Denmark”, Ofgem, Sep. 2020. Available: <https://www.ofgem.gov.uk/publications/decision-final-project-assessment-viking-link-interconnector-denmark>

Ofgem Large Onshore Transmission Investment Project Assessments

“Argyll and Kintyre project - Initial Needs Case consultation”, Ofgem, Sep. 2022. Available:
<https://www.ofgem.gov.uk/publications/argyll-and-kintyre-project-initial-needs-case-consultation>

“Dinorwig-Pentir - Decision on the project’s Final Needs Case”, Ofgem, Aug. 2022. Available:
<https://www.ofgem.gov.uk/publications/dinorwig-pentir-decision-projects-final-needs-case>

“Eastern HVDC – Conditional Decision on the projects’ Final Needs Case”, Ofgem, Jul. 2022. Available:
<https://www.ofgem.gov.uk/publications/eastern-hvdc-conditional-decision-projects-final-needs-case>

“Harker – Decision on the project’s Initial Needs Case and its suitability for competition”, Ofgem, Oct. 2022. Available: <https://www.ofgem.gov.uk/publications/harker-decision-projects-initial-needs-case-and-its-suitability-competition>

“Direction for the Hackney Waltham Cross Upgrade North London reinforcement project”, Ofgem, Jul. 2022. Available: <https://www.ofgem.gov.uk/publications/direction-hackney-waltham-cross-upgrade-north-london-reinforcement-project>

“Direction - North West Wales Pre-Construction Funding Request”, Ofgem, Sep. 2022. Available: <https://www.ofgem.gov.uk/publications/direction-north-west-wales-pre-construction-funding-request>

“Orkney transmission project – May 2021 update”, Ofgem, May 2021. Available: <https://www.ofgem.gov.uk/publications/orkney-transmission-project-may-2021-update>

“Isle of Skye - Decision on the project’s Initial Needs Case and on its suitability for competition”, Ofgem, Apr. 2022. Available: <https://www.ofgem.gov.uk/publications/isle-skye-decision-projects-initial-needs-case-and-its-suitability-competition>

“Update on the Western Isles transmission project and potential next steps”, Ofgem, Oct. 2019. Available: <https://www.ofgem.gov.uk/publications/update-western-isles-transmission-project-and-potential-next-steps>

“Yorkshire GREEN - Decision on the project’s Initial Needs Case and initial thinking on its suitability for competition”, Ofgem, Feb. 2022. Available: <https://www.ofgem.gov.uk/publications/yorkshire-green-decision-projects-initial-needs-case-and-initial-thinking-its-suitability-competition>

Other Sources of Cost Information

“CAPITAL COSTS FOR TRANSMISSION AND SUBSTATIONS Recommendations for WECC Transmission Expansion Planning”, Western Electricity Coordination Council, Oct. 2012

“Transmission Cost Estimation Guide: MTEP19”, MISO, Dec. 2019

“Independent study to examine the technical feasibility and cost of undergrounding the North-South Interconnector”, Government of Ireland, Apr. 2018. Available: <https://assets.gov.ie/123264/30728987-fa2f-4549-81ea-e931523c43e7.pdf>

“Report for Commission for Regulation of Utilities - Consultancy Support for Electricity Transmission and Distribution Revenue Controls”, GHD and CEPA, Jul. 2020. Available: <https://www.cru.ie/wp-content/uploads/2020/07/CRU20076a-Consultancy-Support-for-Electricity-Transmission-Revenue-Controls-2016-2025.pdf>

D. Elliott et al., “A Comparison of AC and HVDC Options for the Connection of Offshore Wind Generation in Great Britain”, IEEE Transactions on Power Delivery, vol. 31, no. 2, pp. 798–809, Apr. 2016. Available: <https://doi.org/doi:10.1109/tpwrd.2015.2453233>

“Investment cost model and cost parameters for the estimation of HVDC project costs”, NSON and Fraunhofer IEE, Nov. 2022

“Transmission Networks: Offshore Development Information Statement”, National Grid, Dec. 2009

“Offshore Transmission Technology”, ENTSOE, Nov. 2011. Available: https://eepublicdownloads.entsoe.eu/clean-documents/pre2015/publications/entsoe/SDC/European_offshore_grid_-_Offshore_Technology_-_FINALversion.pdf

“World Energy Investment 2022”, International Energy Agency, Jun. 2022. Available: <https://www.iea.org/reports/world-energy-investment-2022>

M. Letter from Project Board



Futures Place
Kings Way
Stevenage
Hertfordshire
SG1 2UA
United Kingdom
T +44 (0)1438 313311
W theiet.org

23 September 2022

Dear Sir/Madame,

COMPARISON OF ELECTRICITY TRANSMISSION TECHNOLOGIES AND THEIR POTENTIAL USE IN GREAT BRITAIN

As communities around the world strive to harness renewable energy resources, electricity transmission companies face strong public opposition to the construction of new overhead lines to accommodate the new generators and associated power flows. Faced with this challenge, Great Britain's three onshore electricity transmission owners have asked The Institution of Engineering and Technology (IET) to commission an independent review of electricity transmission technologies. The IET has, in turn, engaged a Project Board to oversee the study and ensure its independence¹, and Britain's energy regulator, Ofgem, and the UK Government have expressed support for the work.

The project will update the findings of a previous independent assessment, widely cited in many countries², and compare the different approaches that may be used to increase the capacity of the electricity transmission network to transfer power across the different geographies of Great Britain and its surrounding waters.

I wish to request your assistance with the provision of information to the study, particularly on costs. Any data supplied will be held in confidence and used solely within the project for deriving cost ranges.

The study will be performed by Mott MacDonald, an international engineering consultancy, and will consider, among other things:

- the costs of each transmission technology (during construction and over assets' lifetimes);
- typical timescales for the design, procurement, manufacturing, construction and commissioning of different technologies;

¹ The Board is chaired by Prof Keith Bell, holder of the ScottishPower Chair in Future Power Systems at the University of Strathclyde, and includes John Loughhead, former Chief Scientific Advisor to the UK Government's Dept. of Energy and Climate Change, Katherine Jackson, an independent consultant and a Programme Advisor with the World Energy Council, and Prof Andrew Lovett, Professor of Geography in the School of Environmental Sciences at the University of East Anglia.

² Parsons Brinkerhoff in association with CCI Cables, *Electricity Transmission Costing Study – An Independent Report Endorsed by the Institution of Engineering & Technology*, January 2012. Available: <https://www.theiet.org/impact-society/factfiles/energy-factfiles/energy-generation-and-policy/electricity-transmission-costing/>

- impacts from the construction and use of each technology, including on the environment and on power system operation; and
- the potential for use of novel technologies.

Mott MacDonald is approaching a number of organisations over the coming weeks to request data – particularly costing data – that will be used to inform the study. I would be most grateful for any assistance you can provide to ensure a supportive response from departments within your organisation.

Any new transmission network developments, whether in Britain or elsewhere, are likely to be faced with the challenge of balancing cost with environmental impact, the timeliness of delivery and ease of incorporation into the system. This study has thus been commissioned to inform all those involved in the design, planning and consenting of new transmission connections and, in particular, stakeholders external to the electricity supply industry. The intention is to publish the results towards the end of February 2023.

It may be helpful to know that I am writing with a similar request to other key suppliers and users of transmission technologies around the world.

If you or your colleagues should have any queries regarding this request, either now or following any approach regarding cost data, please contact [REDACTED] The

I thank you in anticipation,

[REDACTED]

[REDACTED] FRSE, FHEA, CEng, BEng (Hons), PhD, MIET

Chair of the Project Board

N. List of Organisations Approached

Table N.1 provides a list of the organisations that were contacted to provide data in respect of this report.

Table N.1: List of organisations approached

Name of Organisation	Description
3m	Supplier of overhead line conductor
50Hertz Transmission GmbH	Transmission system owner/operator in North and East of Germany
Al Babbain	Transmission tower supplier
Allied Insulators	Supplier of insulators for substations and overhead lines
American Superconductor Corporation	Superconductor supplier
APAR	Supplier of overhead line conductor
AZZ I CGIT Systems, Inc	Supplier of gas-insulated busbar and gas-insulated line
Balfour Beatty plc	EPC contractor for substations, cables and overhead lines
Burns & McDonnell	EPC contractor for substations
Cable Consulting International	UK based cable consultancy
Commission for Regulation of Utilities (CRU)	Irish utilities regulator
CTC Global	Supplier of overhead line conductor
EGE	Supplier of transmission equipment including towers
EirGrid plc	Transmission system operator in Ireland
ElecLink	Owner/operator of 1GW GB/France interconnector (operational)
Energinet	Transmission system owner/operator in Denmark
Energy UK	Trade association for UK energy industry
European Network of Transmission System Operators (ENTSO-E)	European association for cooperation of electricity transmission system operators
ESB Networks	Irish transmission owner
Europacable	Representative body for European cable manufacturers
FAB Link	Proposed 1400 MW GB/France interconnector (in development)
Fingrid	Transmission system operator in Finland
GE Grid Solutions	Original equipment manufacturer for substation, HVDC and other transmission products
Greenlink Interconnector Ltd	Owner/Operator of 500 MW GB/Ireland interconnector (under construction)
Gridlink	Proposed 1400 MW GB/France interconnector (in development)
Global Marine Systems	Offshore installation contractor
Had Fab	Supplier of steelwork and towers
Hellenic	Supplier of cable and conductor
Hitachi Energy	Original equipment manufacturer for substation, HVDC and other transmission products
HivoDuct	Supplier of pressurised air cables
HochTief	Construction contractor with tunnelling capability

Name of Organisation	Description
International Cablemakers Federation (ICF)	Representative body for international cable manufacturers
J Murphy and Sons/Murphy Group	EPC contractor for substations and cables
Kodar	Serbian EPC contractor with particular expertise in overhead lines
KTL	EPC contractor for substations and overhead lines
Lamifil	Supplier for overhead line conductor
Linxon	EPC contractor for substations
LS Cable & System	Korean cable supplier
Mitas	Supplier of transmission towers
Mitsubishi	Original equipment manufacturer for substation, HVDC and other transmission products
Morgan Sindall	EPC contractor for substations and overhead lines
Morrisons Energy Services	EPC contractor for substations and overhead lines
Mosdorfer CCL Systems Ltd	Equipment supplier for overhead lines
National Grid Electricity System Operator	Electricity system operator in GB
National Grid Electricity Transmission	Transmission owner in England and Wales
NeuConnect	1400 MW GB/Germany interconnector (under construction)
Nexans	Cable and superconductor supplier
NKT	Cable supplier
NorthConnect	1400 MW GB/Norway interconnector (in development)
Offshore transmission operators:	Licensed GB offshore transmission operators
<ul style="list-style-type: none"> ● Balfour Beatty ● Equitix ● Transmission Capital ● Blue Transmission ● Diamond Transmission 	
Orsted	Wind energy owner and developer
Overhead Line Fittings	Supplier of overhead line materials
Pace Networks	Supplier of overhead line materials
Painter Brothers UK	Supplier of steelwork and towers
Preformed Line Products Ltd	Supplier of overhead line materials
Prysmian Cables and Systems	Cable supplier
Renewable UK	UK renewable energy trade association
Royal Institute of Chartered Surveyors (RICS)	Professional body for surveyors
RWE	Global energy company which is active in the offshore wind sector
Scottish and Southern Energy Transmission	Transmission owner in Northern Scotland
Siem Offshore Contractors	Offshore installation company
Siemens Energy	Original equipment manufacturer for substation, HVDC and other transmission products
SmartWires	Engineering consultancy and equipment supplier with focus on static series synchronous compensation equipment
Solidal	Cable and conductor supplier
System Operator Northern Ireland (SONI)	Transmission system operator in Northern Ireland
SP Energy Networks	Transmission owner in Southern Scotland

Name of Organisation	Description
Statnett Norway	Transmission system owner/operator in Norway
Sterlite	International developer of power transmission infrastructure
Südkabel	Cable supplier
Sumitomo Electric Industries	Cable supplier
Supernode	Developers of superconductor technology
Svenska Kraftnät	Transmission system operator in Sweden
Taylor Woodrow	Contractor
Taihan	Cable supplier
TenneT	Transmission system operator in Netherlands and parts of Germany
Vinci	EPC Contractor including Omexom
Volker	Cable installation contractor
Wood Group	International engineering and consultancy business with EPC capability
Zamil	Tower supplier
ZTT	Conductor supplier

O. Abbreviations and Acronyms

The following abbreviations or acronyms are used throughout this report.

Table O.1: Abbreviations and Acronyms

Abbreviation/Acronym	Definition
A	
A	Amps
a.c.	Alternating Current
AAAC	All Aluminium Alloy Conductor
B	
-	
C	
CCT	Circuit
CSC	Current Sourced Converter
D	
d.c.	Direct Current
DNO	Distribution Network Operator
E	
EPC	Engineer, Procure, Construct
ESO	Electricity System Operator
ETYS	Electricity Ten Year Statement
F	
-	
G	
GB	Great Britain
GIB	Gas-insulated Busbar
GIL	Gas-insulated Line
GIS	Gas-insulated Switchgear
H	
HND	Holistic Network Design
HTLS	High Temperature Low Sag
HVAC	High Voltage Alternating Current
HVDC	High Voltage Direct Current
I	
IDNO	Independent Distribution Network Operator
IET	Institution of Engineering and Technology
IPC	Infrastructure Planning Commission
J	
-	
K	
-	
L	
LCC	Line Commutated Converter

Abbreviation/Acronym	Definition
M	
MCA	Multi Criteria Analysis
MEWP	Mobile Elevated Work Platform
MP	Member of Parliament
MVA	Mega Volt-Amp
N	
NETS	National Electricity Transmission System
NG ESO	National Grid Electricity System Operator
NGET	National Grid Electricity Transmission
O	
O&M	Operation and Maintenance
OEM	Original Equipment Manufacturer
OFTO	Offshore Transmission Owner
OHL	Overhead Line
P	
-	
Q	
-	
R	
RFI	Request for Information
S	
SF ₆	Sulphur-Hexafluoride
SHET	Scottish Hydro Electric Transmission plc (also known as SHE Transmission)
SPT	Scottish Power Transmission plc
SQSS	Security and Quality of Supply Standard
SSSC	Static Series Synchronous Compensator
STATCOM	Static Compensator
SVC	Static Var Compensator
T	
TCSC	Thyristor Controlled Series Capacitor
TO	Transmission Owner
ToR	Terms of Reference
U	
UGC	Underground Cable
UHV	Ultra High Voltage
V	
VSC	Voltage Source Converter
W	
-	
X	
XLPE	Cross-linked Polyethylene
Y	
-	
Z	
-	

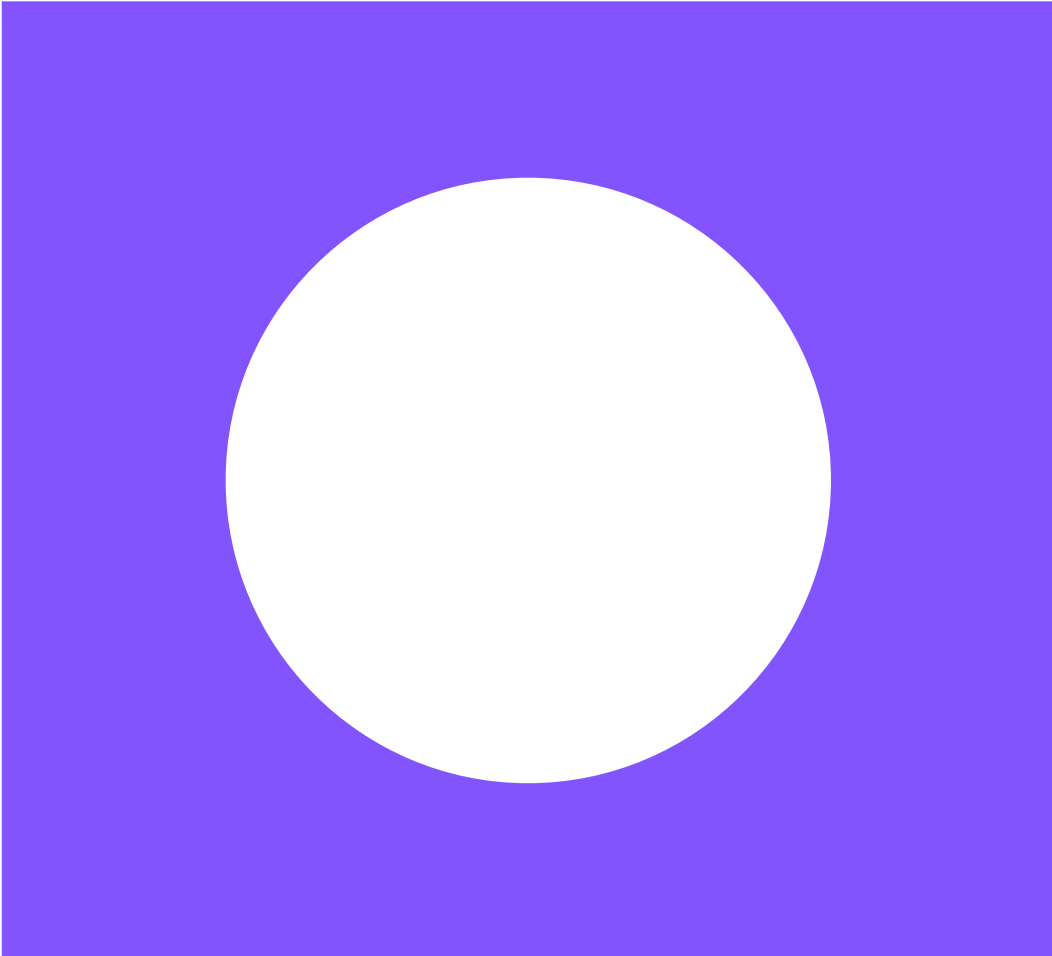

Contact information

London, UK

T +44 (0)20 7344 8460
E faradaycentre@ietvenues.co.uk

Stevenage, UK

T +44 (0)1438 313311
E postmaster@theiet.org

Beijing, China*

T +86 10 6566 4687
E china@theiet.org
W theiet.org.cn

Hong Kong SAR

T +852 2521 2140
E infoAP@theiet.org

Bengaluru, India

T +91 80 4089 2222
E india@theiet.in
W theiet.in

New Jersey, USA

T +1 (732) 321 5575
E ietusa@theiet.org
W americas.theiet.org

@TheIET     

theiet.org

The Institution of Engineering and Technology is registered as a Charity in England and Wales (No. 211014) and Scotland (No. SC038698). The Institution of Engineering and Technology, Futures Place, Kings Way, Stevenage, Hertfordshire, SG1 2UA, United Kingdom.

*A subsidiary of IET Services Ltd.

ATP Cable Ploughing submissions summary paper

Papur cryno ar gyflwyniadau ynghylch gosod ceblau

Cable Ploughing submissions summary paper

Cynnwys / Contents

Rhagarweiniad / Introduction.....	2
Cyflwyniad gan ATP Cable Plough / Presentation from ATP Cable Plough	2
Datganiad tystiolaeth gan ATP Cable Plough / Statement of evidence from ATP Cable Plough.....	3
Cwestiynau gan y Grŵp Cynghori Annibynnol a gyflwynwyd i ATP Cable Plough / Independent Advisory Group questions to ATP Cable Plough	22
Cwestiynau a gyflwynwyd i'r Diwydiant / Questions put to Industry	35
Ymatebion y diwydiant / Industry responses	37
1) Josef Schnell	37
2) IFK GmbH.....	38
3) Föckersperger	39
4) Spiderplow.....	41
5) Tennet.....	43

Rhagarweiniad / Introduction

Mae'r papur hwn yn casglu tystiolaeth o gyflwyniadau ysgrifenedig gan wahanol gwmnïau ynghylch gosod ceblau.

This paper compiles evidence submission text from different companies regarding cable ploughing.

Cyflwyniad gan ATP Cable Plough / Presentation from ATP Cable Plough

Rhoddodd ATP Cable Plough gyflwyniad am y dechneg gosod ceblau i'r Grŵp Cynghori Annibynnol ar Grid Trydan y Dyfodol i Gymru ym mis Medi 2024. Roedd yn cynnwys pwyntiau lefel uchel o'u cyflwyniad ysgrifenedig, gan gyflwyno'r rhain gydag enghreifftiau o brosiectau y maen nhw wedi bod yn rhan ohonyn nhw.

Gwnaethon nhw ddarparu [fideo YouTube](#) byr am y dechnoleg ar waith.

ATP Cable Plough delivered a presentation about the cable ploughing technique to the Independent Advisory Group on Future Electricity Grid for Wales in September 2024. It covered high level points from their written submission and articulated these with examples of projects they have been involved in.

They supplied a short [YouTube video](#) of the technique in practice.

Datganiad tystiolaeth gan ATP Cable Plough / Statement of evidence from ATP Cable Plough

Isod mae datganiad ysgrifenedig o dystiolaeth a gafodd y Grŵp Cyngori Annibynnol gan ATP Cable Plough, sy'n cyflwyno esboniadau'r cwmni o'r dechneg gosod ceblau, ei heffeithiau a'i ffactorau costio, yn seiliedig ar eu profiad o ddarparu gwasanaethau gan ddefnyddio'r dull hwn.

Below is a written statement of evidence that the Independent Advisory Group received from ATP Cable Plough, providing the company's insight into the cable ploughing technique, its impacts and costing factors, from their experience in providing services using this method.

This statement is provided by [REDACTED], Managing Director and owner of A Thomas Plant Hire Limited [ATP Cable Plough].

1. Illustrative and supporting video clips:

There are various video clips available on social media sites, including those of ATP and competitors, which show cable ploughing in action.

One video link is provided below, and three video clips are provided with this statement.

The link ([REDACTED]) is to a video explaining work undertaken by ATP, and showing our equipment in action, for a project on the Dunstable Downs. The client was UK Power Networks, on a site managed by the National Trust, as part of a process of replacing overhead lines and pylons in an area of outstanding natural beauty, instead placing underground by cable ploughing.

The first accompanying video clip shows our equipment in use laying 33KV cable direct into the ground, without ducting, but with backfill to the cables. The clip shows the lead winch, pulling the cable plough, the blade on the cable plough, the backfill carried on an adjacent machine, being laid simultaneously with the cable via a chute on the cable plough, the limited extent and nature of the groove or slit opened by the blade on the plough, and the ease with which the slit can be closed by the tracks of the excavator which follows behind the plough.

The second accompanying video clip shows a side view of ATP equipment in action as part of a demonstration held in April 2024 attended by many leading figures from industry and representatives from Welsh Government. The equipment in use, for the laying of ducting to facilitate cable for 400KV AC, involved a front winch (a spare winch is also shown in the footage but was not in use), the cable plough, and the

excavator following behind – the ducting was laid out adjacent to the equipment so that it could be fed manually into the cable plough. By explanation, if there is no requirement on a project for backfill, and if there is no requirement for direct laying of cable when the cable plough is being used, neither the cable carrier or the vehicle carrying backfill (which are shown via the link and in the first of the accompanying clips) would be required, reducing the equipment involved to just the lead winch, the cable plough, and the excavator following behind. Alternatively, ducts are laid out in readiness to be ploughed, adjacent to the cable route.

The third accompanying video clip provides an overhead view of the demonstration of our equipment during the April presentation. It should be noted that the ground at the time of the demonstration was saturated, after a prolonged period of rainfall. Consequently, the cable plough was put on skis, which is an option available to us, so it could slide over the saturated ground, and so slide marks can be seen which would not normally be evident. The footage helps to demonstrate the low compaction and narrow working strip required for the machines involved as part of the presentation.

2. Illustrative and supporting photographs.

To further assist and illustrate, several still photographs are provided within the schedule attached to this statement.

3. Background:

ATP is a specialist utility plough contractor operating in the UK and elsewhere in Europe. Our cable ploughs install cables and ducts for electricity transmission and distribution as well as for fibre optics and communication, telecoms, gas, water and sewerage. My experience and expertise is derived from:

- many years of direct involvement in laying cables, ducts and pipes by cable ploughing.
- many years of direct involvement in laying cables, pipes and ducts using open trenching/open cut methods.
- 27 years of experience and knowledge of industry practices.

4. Technical information:

- We have used cable plough machinery to lay a variety of electricity cables and a variety of ducts for electricity cables, suitable for cable voltages for alternate current (AC) of 400KV, 220KV, 132KV, 66KV, 33KV and 11KV.
- Cable ploughing has been used and is being used in continental Europe to facilitate the laying of high voltage cables, both for AC and DC.
- The fact that there are sections of the existing transmission and distribution grid networks in the UK which have been undergrounded already, is both indicative, and confirmatory to that extent, that it is feasible and practicable for

high voltage transmission lines and for distribution infrastructure to be placed underground.

- The open cut method (also referred to as open trenching) has with some exception been the traditionally preferred means of placing ducts to facilitate high voltage transmission underground in the UK.
- However, cable ploughing can achieve the same end result as open cut. It is purely an alternative means of delivery. Importantly, cable ploughing minimises the disruption and impact associated with open trenching. Cable ploughing is a very different method of installation to open cut, offering the potential for reduced costs, reduced impacts and speedier delivery.
- I have reviewed various specification drawings for the undergrounding of 400KV using the older method of open cut excavation. I confirm that by using our cable plough machinery to lay the same ducts as shown in the specification drawings, the ducts can be laid at the same depth and at the same distance apart and within the same bedding, as shown in the design drawings for the installation of 400KV by way of open trenching which I have reviewed.
- Specification drawings which I have reviewed for 400KV using open trenching, allow for a maximum depth of 1100 mm between ground level and the top of a duct of diameter 250mm on a bed of 100mm-this specification is easily achieved using the cable plough as the equipment can accommodate cable, pipe or ducts with a diameter of up to 620 mm max and can permit for ducts to be laid up to a depth of 2.8m. Bedding materials if required can be laid simultaneously.
- Based on design drawings reviewed, providing for three phases in flat formation, the width for a circuit at 400KV AC including the spacing between the three ducts, each duct accommodating one phase, could be as little as a width of 2.2 metres in total.
- For a second circuit of 400kV AC in flat formation alongside the first circuit, keeping the spacing between the outer ducts of each circuit at approximately 5 meters dependant on design requirements, two circuits at 400KV could be laid within a strip of just 9.4 m in width.
- Cable plough can be used for laying the ducts required to host transmission cables for high voltage direct current (HV DC) as well as for a variety of transmission and distribution voltages using AC.
- On the basis that only two phases should be required for a HV DC circuit, whereby each of the two phases would be placed within a separate duct, (each duct to be placed in a separate slit opened by the cable plough), the process for HV DC in flat formation would involve just two parallel slits in proximity.
- The Western Power Distribution (WPD) cable installation manual CA 6A, which is available online, permits for double 132KV circuits to be placed within the same duct, but expresses a preference for each circuit to be placed within

an individual duct and for the ducts to be kept separate. The cross-sectional drawing on page 20 of the manual shows 132kV phases in trefoil, whereby the diameter of each of three phases (cables) in trefoil is shown as 100mm in diameter, and therefore each set of three cables together in trefoil being one circuit is circa 300mm (3cm) in diameter, with the spacing between each circuit in trefoil no more than 650mm apart. This would require two ducts only (one for each circuit comprising three phases in trefoil), and therefore just two slits to be opened by the cable plough.

- The appearance of a flat formation is illustrated in the upper right section of the first diagram which is to be found in the schedule of diagrams accompanying this statement. The appearance of a trefoil formation is illustrated in the upper left section of the first diagram
- ATP has facilitated the undergrounding of double circuit 132KV. Cables for a single circuit consisted of three phases in trefoil, tightly together, each circuit placed within a separate duct, each duct placed into an individual slit. Therefore, two slits, each carrying one duct. The ducts were laid at a depth of 1.2m, and the centre-to-centre distance was just 1.5m.
- The 'Sea Green' project in which we were involved was a 220kV link, comprising three circuits. The system was ducted using cable ploughing equipment. The ducts were 225mm in diameter. The communication ducts laid at the same time were 110mm. The machine also installed the master tile with a 100mm separation from the electrical duct and marker tape (warning tape) 100 mm above the stock board.

5. Method and Technical:

- The front vehicle is a winch which can be tracked depending on the terrain or ground conditions.
- The cable plough is winched forward from the front vehicle, which has significant traction and pulling strength.
- The cable plough places cable or duct in a sensitive way, installing the cable or duct within a slit cut in the ground by the blade of the cable plough as the cable plough moves forward.
- As it opens a slit in the ground the cable plough can simultaneously lay into the slit each of the ducts (or cables if cable installation direct into the ground is preferred) required to be placed in the slit, together with fibre optic cable if required, warning tape, and the protective plate, placing in order and with precision.
- Depending on size or weight, coils of cable or ducting can be carried on the cable plough or can be carried on and fed from a separate drum carrier travelling in convoy. As an alternative, ducts can be laid out on the ground, uncoiled, running within the easement strip, immediately adjacent to the route of the cable plough, so that the ducts can then be lifted and fed manually into the chute of the cable plough as it moves forward.

- The cable plough can also lay simultaneously any imported backfill -if backfill is necessary it is fed into a chute from a machine running alongside or behind the cable plough which carries the selected bedding material which passes via a conveyor into a chute fitted to the blade of the plough. The process is controlled and timed so that the cable or duct remains suspended until the bed has been laid.
- The slit opened by the plough is closed by the tracks of the excavator which follows behind. It is just flattened back over. If we are ploughing firm ground, the excavator may need only drive over the slit to close it back. If the ground is wetter, or if ground conditions are such that there is a need for more attention to prevent scarring, there may be some bucket work with the excavator but limited to ensure a smooth surface ready for seeding.
- The equipment allows us to cut, install and back-fill - all in one operation.
- Up to 1.5 km a day is achievable for the opening of a slit and for the simultaneous installation into the slit and for closing over by the excavator following behind the cable plough.
- We averaged 1.45 km a day on the Sea Green project. Cable ploughing through the rural countryside of Wales (general geological information for Wales is in the public domain) or passing through well worked agricultural land, is expected to be comparable.
- If more than one parallel slit is required, the machine would need to undertake an additional run for each additional slit. We own a number of cable plough machines which could be put to work on the same route at the same time.
- Even if operation should be limited to an average of 1km a day, then for a route of 75km requiring six slits to facilitate the ducting for a double circuit at 400KV AC in flat formation, an overall total of 450 days' work(75 x 6) could be reduced by using four machines on the route so that by dividing 450 by four the ducting for the whole route of 75km could be laid in circa 112 days.
- Limiting to an average of 1km a day, then for a route of 75km requiring two slits to facilitate the ducting for a HV DC circuit or a double circuit at 132KV applying the specifications within the Western Power Distribution (NGED) manual CA 6A, an overall total of 150 days' work (75 x 2) could be reduced by using four machines on the route so that dividing 150 by four the ducting for the whole route of 75km could be laid in circa 38 days.
- If four slits should be required, possibly for two circuits of HV DC, then assuming operation should be limited to 1km a day, an overall total of 300 days' work (75 x 4) could be reduced by using four machines on the route so that dividing 300 by four the ducting for the whole route of 75km could be laid in circa 75 days.
- Of course, if progress should be made somewhere between 1.4 km to 1.5km a day, the delivery of the ducting including closing over could be achieved even more quickly.

- GPS is used to vary the height of the cutting blade adjusting automatically to the ground surface. The unique design of the combined blade and guidance system means that pipes and cables are laid exactly in accordance with regulations – whatever the speed of travel. Inspections have proved that installations carried out by the Cable Plough can be of better and more uniform quality than that of open trench methods.
- The Cable Plough's operation means that its cutting blade is controlled in such a way that the insertion angle is adjusted to the curvature of the earth. This means that cables and pipes are carefully laid, with no strain or tension.
- The enormous pulling force of the mobile winches and the tractive force is a big advantage, together with the adjustable outriggers on the plough. Each installation project starts with the power-winch being safely sited ahead of the Cable Plough in an area where it can secure itself by dropping its anchor into the ground. However, in the case of roadside installations, the winch is capable of gripping to the asphalt without the need of its anchor. It is important that the tracked crawler is well grounded, but the flexibility and manoeuvrability of the machines, provides a potential to work on significant terrain and gradient.
- We have been comfortable using the equipment on gradients up to 45 degrees. Some of the photographs included in the accompanying schedule of photographs illustrate work undertaken on significant gradients.
- The adaptability of the cable plough enables it to cope with a variety of surfaces, whether flat, hilly, or undulating terrain. The photographs for the Boat of Garten project displayed on our website, of which some are included within the schedule of photographs which accompanies this statement, are indicative of what can be achieved in terms of gradient and terrain.
- The cable plough equipment is suitable for various soil conditions, including sand, gravel, and moor. Difficult ground conditions have been encountered and managed. The hydraulically adjustable ripper shoe allows the desired depth to be maintained continuously, even with changing soil conditions, which allows work to be carried out without interruption and avoids costly reworking.
- The machinery is capable of operating in wet and adverse areas, such as across marshland, through ditches and even into rivers. For small rivers or tributaries, as the cable plough is classed as trenchless, we can plough across the riverbed. We can negotiate water crossings up to a depth of 1 metre. If a river is wide or deep or protected, then horizontal direct drilling could be a supplement used to accompany the work of the cable plough.
- When encountering hard rock or rock layers, we have been able to break it out first before continuing to cable plough. It may also be possible to route around hard rock. We were involved in the Boat of Garten (Vista) project in February 2020, as subcontractor for Morgan Sindall which was the Tier 1

contractor. Ground conditions were particularly hard in places with boulder fields and fractured rock sections, and a covering of deep peat in others.

- If major pipework is encountered and has to be crossed, then depending on depth, the pipework can be capped with concrete and cable ploughed over, or alternatively a mini digger or drilling can be used so that cabling or ducting can run under it.
- Land drains are not always mapped, or a landowner's plan showing the position of land drains may not be accurate. If we cut through a land drain in the process of cable ploughing the exact location is recorded. After the duct or cable has been laid, the slit is folded back down, but a specialist drainage firm working with us will then attend to repair the break in the drainage pipe. If damaged during the passage of the cable plough, the ground beneath the drainage pipe, save for the small dimension of the blade, will have remained compacted, therefore providing good support for the land drain and aiding effective replacement connection. The contractor would excavate the small depth to address the cut but during the repair would not excavate underneath it, thereby retaining stability. In contrast, if a land drain is broken during open cut excavation, the section of replacement land drain could be situated on a base which may be insufficiently compact, causing water to hold or a blockage to occur within the replacement section, should the replaced pipe begin to sag because it is not sufficiently supported.
- The question is asked, what distance and for what duration can the machines be used for. The equipment we use, is such that we can continue, subject to avoiding or circumventing obstacles, such as excessive solid rock, for such length required to be cable ploughed. The equipment permits for extensive use in terms of duration or distance.
- Joint bays are created at each point at which cable lengths are to be joined together. The joint bays also facilitate access to the cable once laid.
- Joint bay positions can vary depending on terrain, depending on the lengths of cable used, and depending on the size and weight of cable drums which can be determined both by cable diameter, cable length and cable components specific to each individual project. We also encourage careful routing, not only to shorten the route so far as practicable but to consider the spacing and placement of joint bays as if created near to roads and gateways this can further reduce costs and facilitate ease of access.
- Joint bays are opened with an excavator for each circuit. They can vary in size but would likely average in the region of 13metres long by 2 metres wide. for a double circuit the joint bays may be slightly staggered.
- Roadside projects are possible using the cable plough, providing the roadside verges have not already been utilised for a variety or collection of service media. Because of its agility, the Cable Plough is ideal for carrying out roadside projects, as signs, fences and barriers can easily be negotiated and need not be moved. It can even follow curves in the road to a radius of 4m.

- The all-round flexibility of the equipment enables it to plough around or adjacent to a variety of obstacles, such as rocks, trees, barriers, hedges and walls - by lifting or moving the jibs and positioning the wheels, we can operate to one side of or around an object.
- A minor road can be opened up during the short period of time which is permitted and ploughed through before filling with sand and putting plates over, so the road is passable pending resurfacing. More major road crossings can be avoided by using horizontal directional drilling.
- My company uses machines manufactured by FOECK. The manufacturer could be a source of useful data by way of confirmation of my evidence as to the capacity and capabilities of its machines.
- ATP will lay cables direct into the ground using our equipment, but if the use of ducting is preferred, our equipment is used to lay the ducts, and we do not involve in the follow up work of pulling cable through the ducts. The work of pulling or pushing cables through the ducts once the ducts have been laid would be undertaken by a specialist in that field.
- The use of ducting provides some measure of future proofing, as there is an expectation that ducts would have a lifespan in the region of 100 years and relevant to replacement of cabling, if that should ever become necessary, old cables can be pulled out and new cables pulled or pushed through the ducts.
- Maintenance, repair or replacement of cables laid within ducts should not be necessary unless a section of cable or joint is defective -as cables are pre-tested before they are laid, to ensure that they are satisfactory, the chances of laying a bad conductor should be negated.
- MDP ducts come in 100m lengths which are joined and sealed together for ground insertion, and for that reason are preferable to the use of PVC ducts which come in much shorter lengths.
- The design team for any given project would need to consider carefully and efficiently, the extent to which the ducting used, and the design of the cable to be used (XPLE coating for cable sheaths is becoming more common) may remove or reduce the need for imported backfill under and around the installation – factoring in also the TR value of the ground, the diameter of ducting used and the materials used in the casing of ducts such as MDP/Polythene ducts. It is important to encourage and achieve progressive design.

6. Impacts:

- We arrange an ecology study before starting work, engaging a reputable ecologist. The ecologist will monitor as appropriate as work proceeds. We can then take any mitigating measures required by the ecologist. Likewise archaeological sensitivity can be addressed.
- Dependent on-site survey, very little preparatory work may be required before commencing work.

- The cable plough process can reduce or avoid the need for removal of vegetation and can avoid altogether the removal of topsoil.
- No soil has to be excavated, thus avoiding soil structure changes and subsequent compaction.
- By cable ploughing directly without soil excavation, there is no removal or mixing of soil layers.
- No soil mixing means there is no soil contamination.
- The cable plough displaces, rather than excavating or lifting. This makes the process significantly more environmentally friendly and less disruptive.
- If there is a need to cross a hedgerow, the limited section of the hedge affected can be lifted completely and then re-instated completely within twenty-four hours.
- Compared to the plant used, and the duration of use, for pylon and overhead construction and for open cut methods, our equipment offers the opportunity for lower fuel consumption and a reduction in associated CO2 emissions. The manufacturers' specification suggests around 50 litres of diesel fuel consumed per 1,000 metres of laying distance. During the Sea Green project we recorded fuel consumption, using HVO diesel, at 58 litres per km per circuit. By comparison, installing the same distance with overhead lines and pylons, using alternative machines such as heavy cranes, and where the plant is in use for an extended period, can require far greater consumption of diesel fuel - laying cables with an excavator for open trenching could involve diesel use which is 10-15 times more than for cable ploughing.
- There is an extensive requirement for haul roads for the construction of pylons. The provision of haul roads, increases the carbon footprint, requires the production and carriage of stone, involves construction work, and the excavation and removal of waste. Of course, haul roads also mean additional cost. There is a need to secure access to each individual pylon site, which can result in a significant number of haul roads given that projects proposed for Wales set out the intention for pylons to be placed every 200-250 metres along the route. For undergrounding facilitated by cable ploughing, whilst there is a need to access joint bays at which cables will be pulled or pushed through and jointed, should spacing of individual joint bays average at around 1km, the number of access facilities compared to pylon sites every 200-250 metres would be reduced by a quarter to a fifth, whilst the reduction may be greater again, allowing for the nature of the equipment associated with cable ploughing and pulling through, and reflecting that the placement of pylons is more constrained because of obligations to try and mitigate visual impact, whereas in contrast an important part of undergrounding facilitated by cable ploughing is careful routing and careful placement to encouraging the placement of joint bays near to established access points.

- Whilst traditional methods of pipe and cable installation require a sizable trench to be dug and then refilled, the Cable Plough's efficient way of cutting a narrow slit into the soil causes only minimum disturbance to the land.
- With only a narrow cut into the ground, there is little damage and therefore no structural change to the geological formation of the earth. Considering also, the simple process for closing over, it does not take long for the area of land to return to its original and natural state.
- The techniques used by ATP enable the installation of cable across many areas where traditional trenching is not possible or is discouraged. This can include Sites of Special Scientific Interest (SSSI), Areas of Outstanding Natural Beauty (AONB), agricultural land where production is paramount and disruption unhelpful, National Parks, areas of peat, other areas which are particularly sensitive to ecological and environmental issues, or areas which are not accessible to large plant. ATP call this technique "Trench-less Technology."
- At a time when traditional open-cut methods of service laying are coming under increased scrutiny because of environmental and ground reinstatement issues, the Cable Plough's efficient and low-impact method means that any complications when restoring and subsequently handing back land are dramatically reduced.
- The use of cable ploughing can allow for a reduction in the easement width required for project operation. The land affected can be limited to circa the width of the cable plough. It is our preference that the easement width is a little wider. The third diagram within the schedule of diagrams which accompanies this statement shows the machine width as 3 metres and allows for buffer width of 1 metre on one side and a passing or emergency zone of 4 metres on the other side. Therefore, an easement width of just eight metres in total. The second diagram in the schedule of diagrams illustrates the limited route width allowing for the equipment to navigate a 90-degree turn - that diagram shows a normal corridor width of 10 metres. Therefore, the easement width required is between just 8m to 10 m, but the ground over which the cable plough machine and the lead winch passes can be limited to circa just 3 metres.
- Importantly, the sensitivity of the cable plough process can allow for shorter and more direct routes, as an alternative to longer and diversionary routes which may be required for pylons and open trenching. This provides for an obvious mitigation in terms of land, ecology and bio-diversity impacts.
- The use of cable ploughing technology not only minimises land impacts, but will not interfere with bird flight paths, will not prejudice Ministry of Defence flight exercises, will not prejudice visual amenity, will not prejudice visitor revenue and tourism, can avoid property devaluation, and can encourage community and landowner acceptance. It is important to assess carefully the method and operation of constructing and delivering pylons with overhead

lines to understand the impacts and timescales involved. What is actually involved can too often be conveniently overlooked or understated, and impact comparatives can be offered without a realisation or any focus on the actual disruption and adverse impacts from new overhead proposals involving pylons. There is ample information in the public domain, as to the impacts of open cut methods, as the consequences of open trenching are often highlighted as a diversion from the impacts attributable to overhead lines. However, information as to impacts associated with pylons can be found, and confirmation should also be available from transmission and distribution companies on request, so that a meaningful and honest comparison with cable ploughing methods can be conducted.

7. Costing factors:

- Route length – the mistake can be made of comparing a price per km for overhead lines and a price per km for underground cables, by multiplying the respective prices per km by the same route length, without factoring in that the route length for one method could be considerably shorter than the route length for another method. For example, an overhead line may have to follow an extended route in order to skirt away to reduce visual impact from a National Park, or to try and mitigate unacceptable visual impact more generally, particularly as there is an onus on a developer to try and mitigate by applying the Holford rules, whereas undergrounding by cable ploughing could permit for a far more direct and shorter route to be used. Therefore, the exercise of comparing the costs for overhead lines compared to the costs for underground cables, for any given project, should first involve a realistic determination and calculation, obtained with care, of the route length for overhead and separately the route length for underground, to determine if there is a differential, and if there is a differential, the multiple to be applied to the rate per km relevant to undergrounding, will be different and distinct from the separate multiple to be applied to the rate per km for an overhead line. An overall costing obtained by applying comparative rates per km, could be seriously distorted if the same route length is assumed for each of the options, without proper exploration of the exact route length applicable for each option. Application of the correct route length to the rate per km for an option, could significantly alter or reduce the overall costs for that particular option.
- Just by way of example, it is apparent from a casual examination of the route plan for the proposed overhead development in Wales called the Towy Teifi scheme, that obvious reductions could be achieved as to the route length should the project become an underground project adopting the use of cable ploughing.
- If comparative figures per km are to be used for the purpose of assessing alternative and comparative costings, there is a need to ensure that the

figures adopted per km are all encompassing or are considered alongside and in the light of other relevant figures and costing information.

- The compound costs involved in a project can be £35,000 to £40,000 per week. Therefore, the faster the job, the more costs can be saved or avoided. As the cable plough cuts into the ground, installs and backfills in one operation, it can complete a considerable distance in a day. The equipment we use, together with our highly skilled teams to operate the equipment, leads to the fast and efficient laying of cables. The speed of progress, for so called 'build time' is important. Each project has compound costs including electricity, water, project managers, security, ecology and archaeological specialists.
- It was interesting to read, and to contrast with the speed of delivery offered by cable ploughing, an account within a report provided by a prospective developer of overhead lines with pylons in Wales, as to the likely build time for a proposed overhead project. The description records: 'The total duration of construction activity at any single tower site is approximately two weeks for tower foundations, a further two weeks for tower construction, and up to four weeks for conduction erection and stringing (this depends on the size of the tower and the number of conductors being strung). However, these timescales will not be consecutive as a gap of 4 weeks will be required for the foundation concrete to 'cure', - a further gap will be required for all the towers in a section to be erected before any wiring works can commence. The total construction period is expected to be approximately 4 months per tower'.
- Cable ploughing can offer a significant reduction in time money and risk. It can provide for a huge increase in productivity over and above traditional ways of working. For example, for projects we have undertaken, open trenching methods would have taken up to three weeks per one km distance, compared to one day or more per one km distance using cable plough.
- The more quickly that infrastructure can be delivered, connections can be achieved, minimising or avoiding significant constraint costs.
- To the extent that the cost of clean energy can reduce consumer bills, the sooner that appropriate connections can be completed the better.
- The financial cost, should an insensitive or inappropriate project be delayed by community or landowner opposition, is also an important consideration. Speed of delivery is important from the equipment and contractors engaged for delivery, but speed of delivery through community and landowner acceptance can also be a critical factor.
- Any costing comparative should reflect whole life costs, including projected costs relevant or consequential to the frequency and nature of anticipated maintenance and repair and speed of repair, and primary and secondary cost and loss due to potential outages, remembering that the increasing frequency and power of stormy weather can damage lines above the ground causing disruption, although appreciating the difficulty of putting a figure on the loss of business and loss of revenue experienced by tens of thousands [e] without

electricity or internet connection as a result of damage to overhead lines. Loss of energy, longevity and de-commissioning, should also be factored in.

- It is important to consider whether existing utilities which are on or above the surface, which would otherwise be in too close a proximity to new overhead high voltage lines, will require undergrounding, whether as a legal necessity or as a sensible precaution, and any additional or secondary costs should be factored into the overall costings for any project.
- The cost of fencing, required to protect a site of construction or installation, should be factored in when calculating overall project costs. Whereas excavation all along the route is involved using the open cut method, by contrast cable ploughing does not involve excavation so the sections cable ploughed, as cable ploughing is a trenchless method, do not need to be fenced. This can provide for a considerable saving and acceleration of process.
- Compensatory payments to landowners based on loss of value, loss of use during construction and restoration, loss of revenue from land, and permanent loss of use, can contribute significantly to the costs of a project and should not be overlooked in the exercise of evaluating and comparing overall costs.
- My perception of the merits of cable ploughing as a means of reducing land impacts and therefore minimising the requirement to pay compensation, is also helped as I have direct involvement in agriculture.
- As cable ploughing can minimise ground disturbance, and reduce impact, and as the time spent on a holding can be minimised due to the speed of operation offered by cable ploughing, and as cable ploughing requires a very limited operational width and therefore a limited easement width, and as cable ploughing can avoid unnecessary restriction of access to land which would otherwise be fenced off during an extended period of construction and otherwise followed by a substantial period of restoration, and as cable ploughing can avoid the separation and inaccessibility of one part of the holding (by a fenced off corridor) from the remainder of the holding, cable ploughing can reduce the period and extent of loss of use and loss of revenue and therefore can significantly cut or limit the amount of compensatory payments for these heads of loss.
- As restoration and hand back can be the same day or the next day, whereby the areas disturbed can be seeded and back in use quickly, whilst the land either side of the work strip can be accessed and available to the landowner with loss of use limited to one day, compensation payments can be slashed or rendered unnecessary.
- Compensatory claims can also be minimised or avoided by cable ploughing, as if more impactful methods are used over a longer duration, there is the potential for claims to recover compensation for lost subsidies, whilst if farmers are prevented from releasing slurry because of restricted access to, or restricted use of, sections of their land, loss could be compounded by an

obligation or necessity to reduce herds pending full restoration, which in turn can reduce incomes and place a pressure on the ability to service loans.

- Cable ploughing can therefore significantly minimise compensation payments otherwise payable to landowners. The speed of process, the minimised land impacts, reduced preparatory work, limited restoration works, and the speed of restoration, can help drive down the significant compensatory payments otherwise associated with pylons and with open cut methods.
- Likewise, payments to be made for land rights, reflecting loss of value, could be substantially less in consequence of cable ploughing, in addition to the savings to apply relevant to disruption, loss of use, loss of revenue, and for any other consequential loss.
- Cable ploughing could also provide a considerable saving for the public purse. The consideration of using taxpayers' money to fund compensatory payments to homeowners living in proximity to proposed new pylons, or to provide for contributions to compensation funds for communities, or to fund discounted electricity bills, could be rendered wholly unnecessary if pylons are not constructed and instead new infrastructure is placed underground in a way which minimises impacts and does not cause issues around visual impact.
- If property devaluation attributable to pylons because of visual impact and loss of amenity can be rendered negligible, or ruled out altogether, by cable ploughing new cables underground as an alternative to new overhead lines and pylons, it will avoid the need to compensate for property devaluation and will avoid the friction caused should any scheme in effect substantially under compensate.
- Cable ploughing offers a means to deliver the new infrastructure required in the acceleration to net zero by way of promoting and receiving community and homeowner acceptance and support.
- The 'traditional' methods of laying pipes and cables or erecting overhead lines can be extremely labour intensive and time consuming. Because of the way the cable plough operates, it requires less manual input than traditional methods, relevant to both installation and reinstatement, and therefore relevant to costings.
- Careful routeing is not only essential as a means of minimising costs by reducing route lengths in a practicable way. Careful and well considered routeing, with the assistance of a contractor who has familiarity with the terrain and the methods to be used, is an essential to avoid unnecessary costs more generally. Substantial costs can be saved by routeing, not only to ensure that the spacing and placement of joint bays is appropriate, and to ensure that obstacles can be avoided, if necessary, but also to ensure that road and river crossings are made where the contours and ground differentials and ground conditions are favourable towards reducing costs where possible. I have not been approached to provide a costing for the proposed Towy Teifi route, or in the context of providing a reliable costing and

saving on any unnecessary costs, to provide advice on routing for undergrounding the Towy Teifi scheme, but should a costing estimate be requested and provided, the exercise could be somewhat artificial and unreliable should the developer decline to take up or frustrate any an offer to engage with the design and engineering personnel towards ensuring selection of the most cost effective route for cable ploughing.

- Careful and appropriate design is also extremely important, in addition to careful routing, not just as a means of satisfying the technical considerations for a project, but to do so in a way which can avoid unnecessary impacts and avoid unnecessary costs or at least minimise impacts and costs so far as possible.
- Design drawings if badly designed can increase costings unnecessarily.
- When the consequence of bad design is to over complicate or overstate the technical requirements actually needed to achieve a satisfactory underground system, whether the overstatement or over complication is inadvertent, negligent, or a deliberate action on the part of the designer or developer to help keep to a particular agenda of giving preference to an alternative option, the outcome is that costings reflecting bad design will not provide a true reflection of costs, and will artificially inflate the costs of an underground option
- It is important in assessing any costing comparisons, to firstly explore as far as possible, the accuracy and suitability of the design drawings which have been costed. Relevant to cable ploughing rates, and the cost of opening and closing joint bays, if the frequency of joint bays or the number of cuts required from the cable plough is exaggerated or excessive by reason of the design drawings, then the cost estimate or tender could also be greater than it need be.
- More relevant generally to the costs of undergrounding, there are various factors which interplay with the design drawings which can affect the costings provided. These can include whether the route is to be ducted, the type of ducting to be used, including the diameter, weight, length and composition, the method to be used for pulling or pushing cables through the ducting, and the cables to be used. Cable specifications can vary greatly, reflecting the power/capacity (P) to be achieved and the voltage (V) to be used and therefore the amount of current/ampereage(I) to be accommodated ($P=V \times I$). If the ampereage required to achieve a certain capacity is increased to compensate for limitation in the voltage to be used in pursuit of a target capacity, then there could be an avoidable consequence for cable design and specification, which could impact on the diameter or components of the cabling to be used or which in turn could impact the number of cables or the number of circuits and the spacing and heat dissipation or conductivity or ducting or backfill or the number of cuts, which in turn can impact and inflate costings.

- Estimating the costs for a project I work from the drawings produced to me and the specifications with which I am presented. We carry out operations to correspond with the specific design drawings provided to us by the client. The reliability of those costings and whether they could be suitably reduced is dependent on whether the drawings are as progressive and as reliable and as appropriate as possible and whether the scheme itself for which design is supplied is appropriate.
- The ATP scale of charges per km for using our machinery to lay ducting, or to lay cable without ducting if preferred, is set out in a supplemental statement which I have completed, intended to be shared, subject to conditions, with the officers of Welsh Government serving as the Secretariat for the Independent Advisory Group on future Electricity Grid commissioned by Welsh Government, if that information would be relevant and used to further or complete any case study or costs comparative to be pursued by the Independent Advisory Group.
- There would be costs involved for a project facilitated by cable ploughing in addition to the ATP charging rates for opening, installation, and closing back.
- The cost of materials would include the price of the ducts (if ducts are to be used), the cable costs, and the cost of backfill if required. Cable costs can vary greatly, depending on the size, the specification, and the materials used. Conductors with either copper or aluminium conductors are available. Duct costs can vary depending on size and composition. Prices could likely be significantly less if larger volumes are procured for longer routes.
- The cost of additional services would include the cost of specialist companies, engaged for pulling or pushing the cables through ducts laid by the cable plough, for horizontal directional drilling if required for road and river crossings, and for joining the cables once situated in the joint bays.
- I would add one point for record. The 2012 report compiled by Parsons Brinckerhoff in conjunction with CCI and endorsed by the IET, seemingly took no account of cable ploughing and did not factor in the cost of cable ploughing or the reduced impacts offered by cable ploughing compared to open cut methods of undergrounding. It is to be expected that NESO or OFGEM or the transmission companies or the energy sector would have commissioned an up to date study and exploration of comparative costs and impacts, especially as the cost comparatives in the Parsons Brinckerhoff report are now some 13 years out of date, but in terms of any such study, despite the expertise of my company as cable ploughing specialists and the fact we are based here in the UK, and although cable ploughing has been employed for some time both in the UK and within other European countries, I have not been approached or requested to supply costings or costs information or technical information or information as to reduced impacts from cable ploughing.
- It should help to gather relevant information widely from manufacturers, energy companies, energy associations, contractors, sub-contractors, cable

designers, cable manufacturers, financiers, and funders, involved in cable plough and overhead projects in the UK and in Europe, with direct experience and knowledge. One note of caution - it would be important to assess the reliability of costings from past or current projects, as to whether those costs are fair and reasonable, and of course settled costs are not always indicative of what can be achieved for future projects.

- It must be remembered that costs figures given at a certain date or in response to specific or defined requests, can and are likely to change or become outdated. Generalised cost comparatives, which are based on unsupported assumption or on incomplete or insufficient evidence may be dangerous and unreliable, but costings specific to one instance or which have become out of date also have to be handled and used with some caution.
- There are so many variables which can affect cost estimates at any given time. These can include the terms and conditions of the proposed contract, such as whether payments will be in instalments and how frequently instalments are to be made and whether in arrears and the extent of deferment, or costing estimates can reflect the risk involved including the risk of the client failing to honour its commitments, factoring in liquidity and any instability or lack of resources or an unmanageable extent of debt or an absence of experience without a proven track record of commercial reliability, or whether the client is otherwise likely to be problematic. Working with and for an established and reputable Tier 1 contractor can offer a considerable advantage.
- In addition to routing, and design considerations, the location of the work can have a bearing, also the nature or consolidation of transport and ancillary costs. Logistics can play a part. Economy of scale could be relevant -size and scale and volume can affect pricing as can familiarity. Cost drivers can include fluctuating costs such as the cost of fuel, and the variable costs of raw materials or of manufactured products, and of supply and transport, whilst costs along the chain can depend on the availability and capacity and competition within the supply chain and the extent or pressure of demand.
- Overview costs at the outset of a proposal for development, and specific estimates used for tendering, could be materially different by the time planning consent has been obtained and development is ready to begin.
- It is important that cost, technical and impact comparisons, between proposed overhead lines with pylons and undergrounding, should be realistic, including an accurate assessment of what is required in the process of erecting overhead lines, and focusing by way of a comparative on the best or most favourable method of undergrounding available, otherwise comparatives could provide distorted and inaccurate data.
- Despite the nature and extent of the impacts attributable to open cut methods of undergrounding, and the potential advantages offered by cable ploughing,

open trenching has been the method selected by those seeking to hold out a comparative against the costs and impacts of overhead lines and pylons.

- Cable ploughing has not been used as extensively in the UK as it could, simply because the client has not asked for it. Too often, there appears to be a rigidity which holds back exploration of what is now available, and closed minds are not open to the technological advancements which have been made or show reluctance to embrace the possibilities which exist.
- There have been occasions, when I have tendered for projects for new infrastructure, offering to install underground by way of cable ploughing, but have failed to secure the contract to cable plough, whether because of an absence of insight or an ill founded prejudice or because of resistance to change, and yet, having been denied the opportunity to cable plough a given project, ATP has then been awarded the contract for the open cutting of the same scheme, which not only was more impactful, but at a contract price significantly higher than the amount which ATP would have received if our tender to cable plough had been accepted.
- Equipment and expertise for the use of cable ploughing is available. There has been some take- up so far in the UK, and cable ploughing is being used to facilitate new underground projects for transmission in continental Europe, encouraged by influential top tier contractors such as TenneT operating in the Netherlands and in Germany. There may be some signs of change on the part of the UK transmission companies It seems our assistance in 2024, laying ducting to facilitate 400KV AC placed underground as part of a project in Hirwaun,, working for Morgan Sindall, the Tier 1 contractors engaged by the Drax Group, whilst on a small scale, was the first instance of the use of cable ploughing to facilitate the undergrounding in the UK of electricity cable at 400kV.Our understanding is that the methodology was National Grid approved.
- Appropriate national policy and direction would encourage changing perspectives and practice.
- Certainty of policy could drive down costs and encourage progressive thinking and design.

This statement is provided as a contribution to the evidence base which the Independent Advisory Group has indicated that it is compiling, and by way of supporting the initiative of the Welsh Government in commissioning the Independent Advisory Group. It is hoped that this statement will assist with the objectives and purpose expressed by the Independent Advisory Group. I would reserve right to share the statement more widely at my discretion in circumstances when it might be helpful to do so.

ATP Cable Plough

26th January 2025

Mae'r datganiad yn cyfeirio at glipiau fideo, ffotograffau a diagramau darluniadol ac ategol. Ar hyn o bryd nid yw'r adnoddau hyn mewn fformat hygyrch i'w cyhoeddi ar y we gyda'r testun hwn. Nid yw tudalennau gwe ATP Cable Plough, www.ATPcableplough.com, lle mae llawer o'r delweddau yn cael eu cadw, ar gael i'r cyhoedd ar hyn o bryd (Ionawr 2026) ar ôl i'r cwmni gael ei werthu. Gellir dod o hyd i ddelweddau tebyg ar dudalennau gwe eraill y cwmni, a darperir dolenni i'r rhain yn ymatebion y cwmni yn ddiweddarach yn y ddogfen hon.

The statement refers to illustrative and supporting video clips, photographs and diagrams. Currently these resources are not in an accessible format for web publication with this text. The ATP Cable Plough webpages, www.ATPcableplough.com, where many of the images are held, are not currently (January 2026) publicly available following the sale of the company. Similar images may be found in other company webpages and links are provided in the company responses later in this document.

Cwestiynau gan y Grŵp Cyngori Annibynnol a gyflwynwyd i ATP Cable Plough / Independent Advisory Group questions to ATP Cable Plough

Gofynnodd aelodau'r Grŵp Cyngori Annibynnol a allen nhw ofyn ychydig o gwestiynau i ATP Cable Plough ar ôl adolygu'r dystiolaeth a gyflwynwyd. Mae'r rhain isod, gyda'r ymatebion gan ATP Cable Plough.

Members of the Independent Advisory Group asked for a few questions to be put to ATP Cable Plough after reviewing the evidence submission. These are below, with the responses from ATP Cable Plough.

Replies to enquiries about cable ploughing:

This document is provided by [REDACTED], Managing Director and owner of A Thomas Plant Hire Limited [ATP Cable Plough] in response to enquiries received on 14/3/25 on behalf of the Technical Group of the Independent Advisory Group on Future Energy Grid in Wales as to a statement of evidence 26/1/25 provided to the Independent Advisory Group.

Information relevant to some of the questions raised has already been clearly set out and is evident within the detailed statement of evidence dated 26/1/25. However, I remain committed to help and inform the Independent Advisory Group and to contribute to the evidence base which the Independent Advisory Group is compiling, and with this in mind, enquiries and statements set out in the email received 14/3/25 are reproduced below in italics followed in each case by my replies or comments.

1. Can ATP please clarify their experience of the design and/or installation of high voltage power cables using the cable plough technique for power cables operating at 132kV to 400kV. Including information on both the operating voltage, cable design configuration and installed length as well as information on the installation method(s) used – e.g. whether ducts or a direct buried installation method.

The statement of evidence makes very clear that ATP is not responsible for the design of the power cables which it lays or for the design of the power cables which are placed into the ducts laid by ATP to facilitate the undergrounding of cables.

Relevant to design, the statement of evidence confirmed:

- Estimating the costs for a project I work from the drawings produced to me and the specifications with which I am presented. We carry out operations to correspond with the specific design drawings provided to us by the client. The reliability of those

costings and whether they could be suitably reduced is dependent on whether the drawings are as progressive and as reliable and as appropriate as possible and whether the scheme itself for which design is supplied is appropriate.

- Careful and appropriate design is also extremely important, in addition to careful routeing, not just as a means of satisfying the technical considerations for a project, but to do so in a way which can avoid unnecessary impacts and avoid unnecessary costs or at least minimise impacts and costs so far as possible

- ‘The design team for any given project would need to consider carefully and efficiently, the extent to which the ducting used, and the design of the cable to be used may remove or reduce the need for imported backfill under and around the installation – factoring in also the TR value of the ground, the diameter of ducting used, and the materials used in the casing of ducts such as MDPE ducts. It is important to encourage and achieve progressive design’

Relevant to installation of ducts/cables the statement of evidence confirmed:

‘ATP will lay cables direct into the ground using our equipment, but if the use of ducting is preferred, our equipment is used to lay the ducts.

‘The design team for any given project would need to consider carefully and efficiently, the extent to which the ducting used, and the design of the cable to be used.’

ATP would not be design responsible on a project, but a prudent designer would wish to have access to a range of data which can inform and determine design, and ATP, if so engaged, would contribute with suggestions on suitable routeing and information as to technical difficulties or opportunities and feasibility as part of the design process. ATP engage with multiple clients to contribute to the route and feasibility of installations. Design for cable ploughing can follow the same parameters and mindset of HDD installations, for which imported backfill is eliminated by a combination of cable and duct specifications.

ATP has experience of projects involving the placement underground of high voltage cables. From 132KV upwards, projects in which we have been involved have with one exception involved the laying of ducting to facilitate placing new electricity cables underground. Within the UK we laid the ducting for 400KV as part of the Hirwaun project for Drax. The Teir 1 contractor was Murphys & Sons. We laid the ducting using cable ploughing for the 220KV project known as Sea Green and we laid the ducting for the 132KV double circuit project at Portishead. Nexans pulled and jointed the cabling for the Sea Green project. ATP pulled the cables for Portishead, although more usually this would be undertaken by a sub-contractor or by another company working alongside ATP, and Balfour Beatty jointed. Prysmian were involved in pulling through and jointing the cabling for the Sea Green project. More recently we have worked with TenneT in the Netherlands on two projects, laying ducting for 150KV,

and laying cables directly for 220KV. The 150KV was circa 1km and the 220KV was circa 2.8 km. The 400KV ducting was a short distance.

It is important to emphasise, that companies with their own commercial interests or who are simply disposed to using pylons or open cut because that is how it has been done in the past, have limited the opportunities to progress forwards with new proven alternatives. In the UK this tendency has limited the opportunity to apply cable ploughing methods to new projects. I gave the example in my statement of evidence of engagement in a project which involved open cut, although I had submitted as an alternative a tender to cable plough the project, and that the open cut was far more impactful, took far longer and cost a lot more (to my benefit) than the option of cable ploughing which would have been so much more beneficial for the client.

The opportunity to be more progressive and constructive is available, transmission companies and DNOs are beginning to embrace the technology and methods which can be used as the portfolio of works increases.

ATP can assure that the equipment and expertise exists to be able to use cable ploughing to lay ducting together with associated materials if required to facilitate higher voltage cables.

Undergrounding of high voltage lines has plentiful precedent, here in the UK and Europe, and what cable ploughing offers is an alternative method of placing underground, which offers quicker delivery and far less impact compared to open cut, and yet which can place the ducting with the spacing and depth necessary.

Cable ploughing of ducts is very well established, and the technology is proven. Our equipment would have no problem handling ducting required for 132KV, 220kV, 275KV, 400KV, or in delivering over long distances.

The availability and feasibility and advantages of cable plough methods is being increasingly recognised and acknowledged, to facilitate higher voltage cables included.

Without being able to give project specifics at this stage, I can confirm that ATP has been involved in considering and advising and providing competitive tendering for separate proposals in and outside of Wales - for 132KV, 150KV and 275KV respectively, and for a longer 400KV route involving twin circuits, whilst in respect of projects intended for Wales ATP remains prepared to give the assistance which is necessary to provide accurate costings based on informed and previous design specifications and to assist in the exercise of careful and appropriate routeing with careful consideration, which is essential if costings are to be reliable for projects intended within Wales.

Presumably the Independent Advisory Group Technical Group will also have made enquiries of other cable plough contractors as to the nature and extent of their experience and projects undertaken, and the Independent Advisory Group will have

explored the use of cable ploughing for the 700km Sued Link project in Germany involving HV DC which I believe is at 525KV, and for the Sud Ost link in Germany at 380KV which involves cable ploughing circa 45km.

2. Does ATP have experience in the design and installation of power cables for such[400KV] applications? Or just the installation of the cable ducts?

The experience of ATP at 400KV involves laying the ducting to facilitate the installation of the cabling.

In addition, we have reviewed various design drawings for 400KV open cut, which also involved laying ducts with the cabling to be pulled through at the jointing station. Our cable plough machinery can be used to lay power ducts as shown in specification drawings, whereby the ducts can be laid at a constant depth and at the same distance apart and within prescribed bedding, as shown in the design drawings for the installation of 400KV by way of open trenching”.

Has ATP confirmed Installation of cables in ducts reduces the heat dissipation that can be achieved:

There is some overlap between this question and the first question as to the role of ATP in design-please see the replies in response to question one. In addition, the statement of evidence confirmed: ‘The design team for any given project would need to consider carefully and efficiently, the extent to which the ducting used, and the design of the cable to be used may remove or reduce the need for imported backfill under and around the installation. For projects completed by ATP to date on ducted HV installations backfill has been eliminated in the design phase. The approach has been to adopt the principles of conducting HDD where backfill is not viable, but deratings are applied.

Presumably the Independent Advisory Group technical group will have noted or explored the use and purpose of ducting, including MDPE ducts, for considerable undergrounding of high voltage cables which has been undertaken in the UK and more widely within Europe.

Installation in ducts is therefore typically a limiting factor for underground cable circuit capacity design.

This is presented as a statement rather than a question- the statement seems inconsistent with the use of ducting for higher voltage cables for completed projects and of course rather than ducting being a limiting factor ducting can be considered as an enabler, protecting the cabling placed within the duct and offering future proofing. MDPE ducting seems to offer very good protection and an extensive lifespan, so that if replacement, especially upgrade of cabling becomes necessary, the ducting whether placed by open cut or cable ploughing or for the exercise of horizontal direct drilling, enables cable to be pulled out and replacement or upgrade cable to be pulled through the ducts which would remain in position. As mentioned

elsewhere in these replies, cable and circuit design can facilitate a combination of cable and ducting which can eliminate the need for imported backfill.

Has ATP confirmed that that the same cable circuit capacity could be achieved by their proposed duct installation technique as with a conventional open trenching method?

This question seems to confuse, implying that cable plough would only be used for ducting whereas open cut would only be used for the direct laying of cable without protection in ducts. The correct position is that open cut can be used for laying cable directly in the ground and also for laying ducts to facilitate the pulling of cable through the ducts, and that similarly cable ploughing can be used for laying cable directly into the ground and also for laying ducts to facilitate the pulling of cable through the ducts.

I have stressed, that review of design drawings for the installation of 400KV facilitated by open cut undergrounding, confirms that by using cable ploughing the same end result can be achieved in terms of the depth and spacing (and imported backfill could be provided if necessary), so what is installed and its finished placement is as per the specifications for 400KV as shown in the design drawings, save installation using cable ploughing as an alternative method of delivery and installation to open cut is much quicker, far less impactful, and can save money.

Or could larger diameter cables potentially be required for cable installation in ducts compared with a direct buried approach?

High voltage installations would be installed in MDPE SDR11 or SDR17 ducts and avoid the direct lay of cables in select bedding. The ducts will offer the mechanical protection. Cable sizes are to be determined by the design team. In the cost calculations cable size may increase but avoiding backfill for the ducts can provide substantial cost and productivity savings to a project. On the high voltage projects in which we have been involved the design has removed the need for backfill to be used and it has been sufficient to lay the ducts to facilitate the high voltage cables without imported backfill.

The intended depth of the ducting to be laid is another consideration, whereby the correct depth applicable in given ground conditions can be an important factor-the advantage which cable ploughing offers is that it allows for precision as to the depth at which ducts/cables are laid. In the Zeeland project recently undertaken, everything stayed constant at a cover plough depth of 1.8m cover over the circuit, so there was no requirement for modifications. The equipment being used for the circa 45km installation of ducting for the 380KV project is identical to the equipment used by ATP.

3. In the Cable Plough Statement, up to 1.5km installation per day is stated with a route of 75km potentially laid in circa 112 days. This appears to consider duct installation only and not the full power cable circuit installation.

The statement of evidence makes clear that the distance per day figure is for direct laying using our cable plough equipment, whether by direct laying of cable into the ground if that is what ATP is requested to do or for the direct laying of duct into the ground if that is what a project requires. It is a measurement of distance per day for the cable ploughing equipment. Whilst in the past ATP pulled through the cable for the Brechfa project, for the PYC project, and for the Portishead project (Balfour Beatty jointed in each case) the statement of evidence made clear that ATP would not routinely involve in the work of pulling cable through ducts or jointing and the statement made clear that the pulling through and jointing of cabling is distinct from using the cable plough equipment to place underground and was not within the estimate of distance per day. 90% of the time ATP do not contract the pulling of cables through the ducts.'

However, I appreciate the opportunity through this question to expand on two important aspects.

First, to enlarge on the speed and distance at which cable or ducts can be laid into the ground using the cable plough equipment. The figure of 1.5km was provided in the statement of evidence as a distance which is comfortably achievable but a greater distance per day is possible. It takes organisation and requires a team working ahead of the cable plough equipment but if any preparatory work is undertaken including the laying out and welding of ducting this increases the speed of passage and 2km plus a day becomes possible. Again, this would be project specific but the ability to proceed along a route quickly in terms of laying into the ground using the cable plough machinery is a major plus.

Second, to confirm that pulling through and jointing could be taking place as the cable plough proceeds along the route. The statement of evidence confirms that the cable plough performs its function and moves on with good progress, and that the slit is closed by the excavator following behind in tandem. Therefore, the pulling through for each stretch completed, from the position of the joint bay, can begin as soon as the cable plough has moved onto the next section ahead on the route, and once pulling through has taken place for any two continuous sections, the jointing work within the connecting joint bay can take place.

What experience does ATP have in the installation of high voltage power cable circuits (e.g. at 132kV, 275kV and 400kV) in ducts and/or direct buried? Both for short and long distances (e.g. the 75km example quoted)?

This duplicates with earlier questions-please see the replies provided earlier within this document.

Is ATP able to provide more comprehensive information on the total installation time likely to be required for both ducts and also power cabling?

The pulling through of cabling is not expected to make any significant difference to the time estimate for placement by cable ploughing. It is useful and necessary for the

cable plough to get a little way ahead on the route before the work of pulling through begins but as the cable plough is proceeding along the route, the work of pulling through can be taking place whilst cable ploughing is in operation ahead on the route. A competent cable pulling contractor would have no problem in keeping up with progress. Jointing is expected to take four to five days for six cables to be joined within a joint bay, but the bigger contractors could engage more than one team for jointing and more than one team for pulling through. For example, there could be cable pulling gangs to match the number of cable ploughs in operation on the route with three or four jointing teams employed. Therefore, just as different cable ploughs can be engaged to work simultaneously on different sections of a project route, different teams can be engaged to work simultaneously to help speed delivery.

Has the information presented by ATP in considering a 75 km installation application taken into account requirements for cable jointing and the maximum size and length of cable which could feasibly be pulled through a duct for each voltage level?

This duplicates with earlier questions-please see the replies provided earlier within this document.

And is the overall time required to complete cable installation via this method anticipated to be quicker compared with a conventional direct buried solution?

Most certainly-I would expect cable ploughing over a route of circa 75km or over a meaningful distance to be far quicker than either open cut undergrounding or overhead lines with pylons. A distance of 1.5 km completed a day, possibly up to 2km or more using the cable plough for cutting the slit, laying the ducting as appropriate, and closing back, compared to an estimated 100-150 metres per day for open cut. Also, relevant to speed of restoration, as cable ploughing can minimise land disruption the restoration period can be a fraction of what is expected from open cut, and this can be very relevant, together with limiting the period during which a landowner is denied access to the easement strip or unable to access land divided off by the easement strip, towards driving down the compensation which would otherwise be payable to landowners for injurious affection and loss of revenue because of pylons or open cut.

While the installation of ducts can potentially be carried out relatively quickly, this does not necessarily translate to a shorter overall installation time. For example, if installation in ducts were to extend and complicate the actual power cable installation process.

This is presented as a statement rather than as a question. Neither is it correct. To correct this statement, please see the information presented within replies earlier in this document.

4. What experience does ATP have with the installation of cables and/or ducts across differing types of ground conditions? A wide range of ground conditions are likely to be encountered across Wales including rock.

ATP has a wide range of experience-this was confirmed in the statement of evidence. The statement confirmed:

- The enormous pulling force of the mobile winches and the tractive force is a big advantage, together with the adjustable outriggers on the plough. Each installation project starts with the power-winch being safely sited ahead of the Cable Plough in an area where it can secure itself by dropping its anchor into the ground. However, in the case of roadside installations, the winch is capable of gripping to the asphalt without the need of its anchor. It is important that the tracked crawler is well grounded, but the flexibility and manoeuvrability of the machines, provides a potential to work on significant terrain and gradient.
- We have been comfortable using the equipment on gradients up to 45 degrees. Some of the photographs included in the accompanying schedule of photographs illustrate work undertaken on significant gradients.
- The adaptability of the cable plough enables it to cope with a variety of surfaces, whether flat, hilly, or undulating terrain. The photographs for the Boat of Garten project displayed on our web- site, of which some are included within the schedule of photographs which accompanies this statement, are indicative of what can be achieved in terms of gradient and terrain.
- The cable plough equipment is suitable for various soil conditions, including sand, gravel, and moor. Difficult ground conditions have been encountered and managed. The hydraulically adjustable ripper shoe allows the desired depth to be maintained continuously, even with changing soil conditions, which allows work to be carried out without interruption and avoids costly reworking.
- The machinery is capable of operating in wet and adverse areas, such as across marshland, through ditches and even into rivers. For small rivers or tributaries, as the cable plough is classed as trenchless, we can plough across the riverbed. We can negotiate water crossings up to a depth of 1 metre. If a river is wide or deep or protected, then horizontal direct drilling could be a supplement used to accompany the work of the cable plough.
- When encountering hard rock or rock layers, we have been able to break it out first before continuing to cable plough. It may also be possible to route around hard rock. We were involved in the Boat of Garten (Vista) project in February 2020, as subcontractor for Morgan Sindall which was the Tier 1 contractor. Ground conditions were particularly hard in places with boulder fields and fractured rock sections, and a covering of deep peat in others.'

If it will offer assurance, contemplating possible routes for the proposed North Wales to South Wales link, and the routes proposed for more recent proposals for 132KV lines within Wales, I would anticipate that the best part if not all of the route could be cable ploughed, and as touched on above, more difficult conditions can be

addressed - careful routeing is an important factor, and likely the holistic planning which is now being considered can taper in to anticipated geological factors.

Can ATP demonstrate successful track record in the installation of power cabling in ducts for high voltage applications above 33kV using the cable plough technique where the installation has been accepted by a major utility company.

Yes- replies provided earlier in this document are relevant.

For SSE Renewables' Seagreen project which is quoted as a reference, the company advised as holding responsibility for the design, supply and installation of the c. 19.5 km of onshore and offshore cabling was Nexans. If ATP was engaged as a sub-contractor by Nexans to support the delivery of part of the overall project scope, this doesn't necessarily mean that ATP has had the opportunity to develop a comprehensive perspective on the overall cable design, supply installation and costs.

This is presented as a statement rather than as a question.

ATP sub-contracted to Roadbridge / Nexans for the work of pulling through and jointing, not the other way around as suggested.

In any event, the statement of evidence provided did not hold out in the way suggested by the statement.

Cable design and supply installation has been addressed in replies to earlier enquiries.

As to costs, the statement of evidence set out a number of considerations relevant to the costs of a project. The importance of routeing for each option, mistakes which can provide for inaccurate calculation of costs per kilometre, speed of delivery from cable ploughing as a means of driving down compound costs, minimised constraint costs, reduced costs in consequence of landowner co-operation, avoiding the need to underground existing utilities, and driving down fencing costs and compensatory payments to landowners by cable ploughing, avoiding property devaluation and damage to the economy, and saving the public purse from the need for compensatory payments for loss of value . In the statement of evidence, I did not hold out an overview of costings from projects in which I have been involved, and neither would I do so. I am only too aware that costs figures given at a certain date are likely to change or become outdated. I am also aware, and made clear in my statement of evidence, that generalised cost comparatives, which are based on unsupported assumption or insufficient evidence can be dangerous and unreliable, but also costings specific to one project can be quite different to the costings which are unique and tailored to the particular circumstances of another project. I made the point in my statement of evidence, that there are many variables which can affect cost estimates at any given time.

Within my statement of evidence I made the offer: 'The ATP scale of charges per km for using our machinery to lay ducting, or to lay cable without ducting if preferred, is set out in a supplemental statement which I have completed, intended to be shared, subject to conditions, with the officers of Welsh Government serving as the Secretariat for the Independent Advisory Group on Future Electricity Grid commissioned by Welsh Government, if that information would be relevant and used to further or complete any case study or costs comparative to be pursued by the Independent Advisory Group.' If that offer becomes relevant to the work of the Independent Advisory Group, there may now be a need to update figures set out in that supplemental statement.

Is ATP able to provide insight into what sections of the route used a cable plough technique and why? And also, why cable installation in ducts rather than direct burial was selected as preferred?

Reduced impact and speed of delivery were essential reasons for the selection of cable ploughing for this project. The Sea Green project involved passing through the site of a world-renowned golf course. There was a need to reduce so far as possible the time spent on site, and there was a need to ensure that the surface was back in use as soon as possible. Therefore, cable ploughing was preferred to open trenching, and of course overhead lines with pylons was not a credible option. I am aware that there was some regret, considering the speed and minimised impact that cable plough offered on this project in very wet and inclement weather, that the same method had not been applied more extensively for the remainder of the route.

Ducts offer the mechanical protection to the cable. If ever there was a fault in the cable, the cable can be winched out and replaced with the ducting in place.

With ducts in place, cable pulling works can commence at any time and not driven by factory lead times by the manufacturer. It allows the plough section to be connected to any open excavation section and the HDD's with ease. Some of our clients are now installing larger ducts than required for future expansion to the network in decades to come. It offers flexibility to the installation.

5.National Grid's technical documentation (e.g. document INT 45349) indicates that installation in ducts is typically a more expensive method to direct burial (c.f. Section 7).... The presented costs and implementation durations presented by ATP in the Cable Plough Statement are very different for direct burial versus ducting (using cable ploughing). Which does not entirely align with the information which has been published by National Grid.

This is a statement rather than a question, but to comment, the technical document is over 10 years old, dated, and whereas ATP discuss advantages and potential cost savings from the use of ducts, ATP also sets out considerable detail relevant to cable ploughing as an alternative to open cut methods, which unfortunately was not covered or considered at all within the 2015 technical guide.

Section 7 says "Direct burial is normally the cheapest method for the installation of underground cables where restrictions on land use are not an issue. Where there is a requirement to cross major roads or through urban areas the costs of this type of major excavation in terms of traffic management, construction and legal restraints can be considerable." – when is restriction on land use not an issue. Even if not confined by buildings, Ofgem licence holders must observe the Schedule 9 obligations to mitigate impacts, and relevant to minimising land impacts for the landowner and minimising environmental, biodiversity, heritage and archaeological impacts, restricting land use should be a relevant consideration every time. Section 7 of the technical guide contains a diagram showing an expansive width and noting that during construction the working width of the land needed is typically 40–65m for open cut. In contrast the statement of evidence confirms that based on 400KV design drawings which I have reviewed, using cable ploughing a double circuit at 400KV could be laid within a strip of circa just 9.4 metres.

Section 7 does indicate 'An alternative, but more expensive method to direct burial is installation using ducts. The advantage of a ducted installation is that the ducts can be installed in shorter sections along the cable route leaving shorter sections of exposed trench, reducing risk and disruption to the general public.'- to lay shorter ducts for the reasons associated with open trenching in the manner envisaged in the 2015 document would unnecessarily increase ducting and operational costs. Longer lengths of MDPE can be preferable to shorter PVC ducts, and there are no such issues when ducting is laid by cable ploughing.

Section 7 is found within the document 'Undergrounding high voltage electricity transmission lines - the technical issues', issued by National Grid. No further information or explanation was provided within Section 7 to explain or justify or support the statements made suggesting a costs differential between direct burial of cables and the laying of ducts. It was not substantiated. It is important to remember that the technical guide was issued on 4 January 2015, over 10 years ago. The document also omitted any mention of cable ploughing and failed to factor in cable ploughing as an alternative method to open trenching or to consider the costs savings which might be achieved by using alternative available technologies.

In my experience the laying of ducts for higher voltages is far more expedient, for the reasons outlined earlier in these replies, but also any saving by avoiding the cost of ducting can be outweighed by additional time on the job with all the associated costs which that can involve. That was our experience in laying 220KV cables by direct burial in the Netherlands recently. Also backfill costs can be greater with direct laying of cable which is higher voltage.

Although cost is not mentioned in the Cable Plough Statement (beyond suggestion of a 'significant reduction' in time, money and risk), other statements made associated with cable ploughing has indicated an expectation that installation costs

would be cheaper than conventional burial methods and potentially on a par with overhead pylon installation.

This is presented as a statement and not as a question. It is not accurate as to the information about costs set out in the statement of evidence – please read the section on costs in the statement of evidence and please see the replies provided earlier in this document. The statement of evidence visited a number of important costs factors which could be reduced by cable ploughing, rather than just making a generalised comment on reduced costs.

The ‘other statements’ referred to could have made clear the potential which cable ploughing offers for significantly reduced impacts.

The question/statement does not make clear which ‘other statements’ it is referring to, but rather than commenting further on statements which have not been produced with the questions and which I have not seen, I will simply confirm that for the reasons outlined in the statement of evidence and earlier within these replies, there are certainly reductions to costs to be achieved by cable ploughing, reduced compensation for loss of land use being a prime example. Further, as made clear in the statement of evidence, there are so many variables which can affect cost estimates at any given time, costs figures given at a certain date can and are likely to change or become outdated, generalised cost comparatives which are based on unsupported assumption or on incomplete or insufficient evidence may be dangerous and unreliable, and costings specific to one set of circumstances have to be handled with some caution if attempting to apply to a different project with different features.

Is the ATP assessment making a like-for-like comparison? Or does the analysis potentially only consider part of the holistic cable installation requirements?

It is best to read the statement of evidence, and the replies provided earlier in this document as to the approach taken to costing comparatives.

6.I have one further question – our technical experts are particularly interested in the Seagreen project you were involved in, as a UK-based project that might serve as a very useful case study for the group or for Welsh Government. You worked with Nexans and SSE Renewables in that project – do you have contacts you could share we us within the project team for either or both organisations please, that we might ask more about the over-arching project and its design etc.?

ATP has established some excellent contacts and of course we would wish to protect and nurture the relationships which we have been able to develop. If there are specific questions or more general assistance which it will help to explore with contacts we have established, in relation to past projects in which we have involved or for a new case study , please let us know what is required and we can provide introduction or liaise to encourage co-operation and assistance, whether that is to help the Advisory Group or to assist the Welsh Government.

[REDACTED], ATP. 24/3/25

Mae ATP Cable Plough wedi cael ei werthu i GT Jones Contracting ers i'r deunydd uchod gael ei ddarparu.

ATP Cable Plough has been sold to GT Jones Contracting since the material above was provided.

Cwestiynau a gyflwynwyd i'r Diwydiant / Questions put to Industry

Anfonodd aelod o'r grŵp cynghori yr e-bost dilynol, ynghyd â'r datganiad cyntaf o dystiolaeth gan ATP Cable Plough at bum cwmni.

The following email, along with the first statement of evidence from ATP Cable Plough, was sent to five companies by a member of the advisory group.

I am a member of the Independent Advisory Group on Future Electricity Grid in Wales, commissioned and created by the Welsh Government.

The Advisory Group is looking at what undergrounding by cable ploughing can offer, as an alternative to overhead lines with pylons, and as an alternative to undergrounding by open cut methods.

The report of the Advisory Group will inform Welsh Government. It will help to inform the public debate. The Department of Energy Security and Net Zero (UK Government) has confirmed its interest in the work of the Advisory Group. The recommendations and principles which the Advisory Group are formulating can help inform policy on new electricity for conveying electricity, in Wales, in the UK more generally, and on a wider platform.

Would it be possible for your company to assist the work of the Advisory Group.

The Advisory Group has received a statement of evidence from [REDACTED], the Managing Director of the company ATP Cable Plough. With the permission of [REDACTED] a copy of the statement of evidence is attached, together with the photographs, video clips and diagrams referred to in the statement.

Would it be possible for you to read the statement and view the attachments. Could you then assist by responding to the following questions:

- a) Are you aware of any amendment which can be made to correct or clarify any of the information provided in the statement?
- b) Save for any correction or clarification which you may identify, is information provided in the statement correct and do you feel able to endorse and agree the statement?
- c) Is there any information additional to that set out in the witness statement which you can provide, to help the Advisory Group gain a better understanding of cable ploughing, the methods and equipment involved, the technical possibilities, any technical limitations, comparative impacts from cable ploughing, and any relevant cost considerations?
- d) Can you provide a little background information about your company including the number of years involvement in placing cables/ducts underground using cable plough equipment, and whether currently or previously your company has also involved in undergrounding using open cut/open trenching methods?
- e) Would it be possible to list the projects which your company has undertaken, to facilitate underground installation of new cable for any voltage AC at 33KV or above, and involving HV DC. For each project listed, could you confirm the year,

the length laid using cable ploughing, whether duct laid or cable directly placed using the cable plough, the transmission or distribution owner, and the voltage?

- f) If you are aware of projects involving the use of cable ploughing by any other company to help install ducts or cables for AC 33kv or above or HV DC could you identify the projects and who is involved.

Questions e) and f) are included as it could really help the Advisory Group to understand the extent to which cable ploughing is an established and proven method.

Your assistance and co-operation would be very much appreciated.

Ymatebion y diwydiant / Industry responses

1) Josef Schnell

From: [REDACTED]@josefschnell.de>
Sent: 13 February 2025 15:35
Subject: AW: Statement of evidence

Hello,

I'm sorry for the late answer.

thank you very much for your inquiry, we would like to answer your questions.

Also our Company Josef Schnell has been around since 1955.
We can now look back more than 70 years of experience with cable plough technology.

I also think that the cable plough technology needs to be brought forward.
The Cable ploughing I still an unknown topic.

For us there no more efficient solution for Laying cables or pipes.

- The high daily capacity
- Low fuel consumption
- No preparatory work which damages the natural environment

Are a small part of the advantages.

- a) Are you aware of any amendment which can be made to correct or clarify any of the information provided in the statement?

From my point an excellent presentation and statement

- b) Save for any correction or clarification which you may identify, is information provided in the statement correct and do you feel able to endorse and agree the statement?

We like to bring the ploughing technology forward

- c) Is there any information additional to that set out in the witness statement which you can provide, to help the Advisory Group gain a better understanding of cable ploughing, the methods and equipment involved, the technical possibilities, any technical limitations, comparative impacts from cable ploughing, and any relevant cost considerations?

Attached is a presentation by josef Schnell

- d) Can you provide a little background information about your company including the number of years involvement in placing cables/ducts underground using cable plough equipment, and whether currently or previously your company has also involved in undergrounding using open cut/open trenching methods?

We are the Josef Schnell company with 4 locations. For over 70 years we have embodied construction expertise, which has been carried on with the 3rd generation.

We are design the infrastructure of tomorrow.

- e) Would it be possible to list the projects which your company has undertaken, to facilitate underground installation of new cable for any voltage AC at 33KV or above, and involving HV DC. For each project listed, could you confirm the year, the length laid using cable ploughing, whether duct laid or cable directly placed using the cable plough, the transmission or distribution owner, and the voltage?

Included in the presentation

Unfortunately my English is not the best, but I hope to be able to help you. If you have any further questions please let me know.



Oberbauleiter
Josef Schnell GmbH Bauunternehmung

Nid yw'r cyflwyniad cysylltiedig ar hyn o bryd mewn fformat hygyrch i'w gyhoeddi ar y we gyda'r testun hwn, fodd bynnag, gellir dod o hyd i ddelweddau a gwybodaeth ychwanegol ar dudalennau gwe'r cwmni.

The accompanying presentation is not currently in an accessible format for web publication with this text, however additional images and information can be found on the company webpages.

[Josef Schnell](#)

2) IFK GmbH

From: [REDACTED]@ifk.at
Sent: 14 March 2025 07:51
Subject: AW: Statement of evidence

Hello

The information in the report is correct. We've laid approximately 500km of pipe in Germany using the same method. The only limitation is the installation depth of 2.30m.

Best regards from Austria

Mit freundlichen Grüßen aus Salzburg, [REDACTED]

[REDACTED]

[REDACTED]

[REDACTED]

Fa. IFK Gesellschaft mbH
Siezenheimerstraße 29a
5020 Salzburg
Internet: <http://www.verlegepflug.at/> (IFK Pflugtechnik)
<http://www.ifk.at/> (IFK Handel)
<https://www.freshfx.at/> (New Media)
[Facebook IFK](#) (Facebook)

FN 68789 k , Gerichtsstand Salzburg
Informationspflicht zum Datenschutz (DSGVO) siehe www.ifk.at

3) Föckersperger

From: [REDACTED]@foeck.com>
Sent: 14 March 2025 18:48
Subject: AW: Statement of evidence

Dear [REDACTED]

sorry for the late response. Please see the attached comments regarding your letter.

- a. Point 4. Amendment: Technical information: Continental Europe, North- and Southamerika, Africa, Asia and Australia
Comment 01: while the blade cuts open the ground, the slot behind it is widened and the slot is supported with a so-called laying "chute" until the cable or pipe has been laid on the ground through this chute. during this laying process, the laying chute is pressed downwards by the frictional forces and the bottom of the trench is thus smoothed out properly. As this installation shaft is hinged, the cable or pipe is never subjected to a transverse load. The

manufacturer (Foeck) develops these patented installation shafts to the highest quality according to customer specifications. For quality assurance purposes, each installation shaft has its own number, which the customer can use to find out from the manufacturer which cable/pipe diameter this tool is suitable for.

- b. In any case, I also find the information you received from [REDACTED] to be accurate and absolutely worth mentioning. There are still many people who aren't familiar with this system or even don't want to get to know it because it's too quick and inexpensive, saving large sums of money that would otherwise be shared among construction companies. In my opinion, it would make sense to reward engineering and planning firms with a bonus for a more cost-effective and innovative solution compared to the open-pit construction method, rather than making the remuneration dependent on a percentage of the construction cost (at least that's the case in Germany).
- c. As mentioned in the letter, it is very important to inspect the project with a plow-laying specialist before issuing a tender to determine what is actually plowable. Their assessment of this represents capital savings and is a tremendous help with further planning. Well-trained and experienced personnel with well-maintained and safe machines are essential and ensure maximum quality and performance. As a manufacturer, Foeck attaches great importance to the quality of the installation and handling of cables and pipes. For this reason, we have introduced a quality label that offers clients and cable manufacturers the opportunity to find out whether the "chute" installation tool is actually suitable for their product. In this way, we want to clearly distance ourselves from users who work with self-made installation tools, causing damage to the cable and thus damaging our reputation and thus that of the installation plow. Another key difference from our competitors with self-propelled plows is that, thanks to the combination of cable winch and installation plow, we do not use vibration for installation (static plow), thus working very gently on the cables. Vibration can cause disadvantages such as loosening the soil, damage to the cables, premature wear of the machine, excessive noise generation, harmful whole-body vibration, etc.
- d. We've been in this business for over 66 years (as a service provider until 2010 and as a manufacturer since 1958), and more than 500,000 km of cables and pipes have been safely installed worldwide using our Foeck installation system. More than 80 systems (winch and ploughs) and over 190 machines worldwide have been built and designed in my company since 1958. We develop installation tools (chutes) according to client specifications for all cable and pipe diameters up to 630 mm. We review feasibility and submit a proposal to the customer.
- e. Our current project is Tennen's South-East Link (2x 525 kVDC), where we are laying two pipe assemblies (3 pipes + cover plate with warning tape) simultaneously, 1.5 m apart, and 1.8 m underground. For a bigger distance we use a single-chute with GPS guiding and recording. Since we haven't offered plowing services ourselves since 2010, it's difficult to say where my customers are currently. In any case, 33 kV and 110 kV (with/without protective conduit) lines are currently being laid. The 525 kVDC (with protective conduit) project is currently underway in Germany. (See photos). MV 33kV is continuously installed all over Europe and North America for

example in Poland, Austria, Germany, Slovakia, Scotland, Romania, USA, Chile.

If you need any more or detailed information, please let me know.

Mit freundlichen Grüßen
Kindest regards

Dipl.Ing. (FH)



Eberspointer Str.6
D-84189 Pauluszell

www.foeck.com

Gellir dod o hyd i ddelweddau a gwybodaeth ychwanegol ar dudalennau gwe'r cwmni.

Additional images and information can be found on the company webpages.

www.foeck.com

4) Spiderplow

From: [REDACTED] <@spiderplow.com>
Sent: 24 February 2025 16:19
To: Gary Jones Solicitors <@garyjonessolicitors.co.uk>
Subject: Re: Fw: Statement of evidence

Dear [REDACTED]

Sorry that it took so long as I've been travelling most part of the past two weeks!

Please let me respond to your queries as follows!

Are you aware of any amendment which can be made to correct or clarify any of the information provided in the statement?

b) Save for any correction or clarification which you may identify, is information provided in the statement correct and do you feel able to endorse and agree the statement?

Being in this plowing business with only these plow machines since 1994 and having started operations in Australia, the US, Canada, Chile, the Philippines, India, Nigeria, Botswana, South Africa, Namibia and Germany from where we serve all of the European countries, I feel professionally capable of confirming [REDACTED] statement to 100%

c) Is there any information additional to that set out in the witness statement which you can provide, to help the Advisory Group gain a better understanding of cable ploughing, the methods and equipment involved, the technical possibilities, any technical limitations, comparative impacts from cable ploughing, and any relevant cost considerations? **Please see attached one of our brochures that give a pretty good understanding about these machines!**

d) Can you provide a little background information about your company including the number of years involvement in placing cables/ducts underground using cable plough equipment, and whether currently or previously your company has also involved in undergrounding using open cut/open trenching methods?

Having acquired over 50 of these machines in the past 31 years and having installed thousands of miles of fiber optic cables, electricity cables, medium and high voltage systems, water & sewer pipes, oil- & gas pipelines worldwide, I can gladly confirm that these machines are the best ones to do that kind of jobs. I would not buy/ use any other machines. However, the best machine is only as good as what the operators are!!!

e) Would it be possible to list the projects which your company has undertaken, to facilitate underground installation of new cable for any voltage AC at 33KV or above, and involving HV DC. For each project listed, could you confirm the year, the length laid using cable ploughing, whether duct laid or cable directly placed using the cable plough, the transmission or distribution owner, and the voltage? **We plow medium voltage cable systems (even plow in one single plow run up to three systems with one foot of spacing in between), almost every day. Currently we are on the German TenneT Sued-Ost-Link, plowing two 280 mm conduits with 5 feet of spacing plus several conduits, warning ribbon and tracer wires for a 525 kV system!**

f) If you are aware of projects involving the use of cable ploughing by any other company to help install ducts or cables for AC 33kv or above or HV DC could you identify the projects and who is involved. **We would be glad to assist/ be involved!**

Questions e) and f) are included as it could really help the Advisory Group to understand the extent to which cable ploughing is an established and proven method.

I have attached a few pictures of projects we did in the past 31 years at different parts of tworld.

Please dont hesitate to contact me should you need any more information!

PS.: I could also send you a link on Wetransfer to receive larger files/ vireos/ pictures! Please advise!

Best Wishes!



Founder & CEO
Gründer & Geschäftsführer
Spiderplow Group of Companies

CHERRY CREEK PLAZA I, 600 S. Cherry Street, Denver, CO 80246 USA
Oberhofener Str. 47a; D-84453 Muehldorf; Germany

Nid yw'r delweddau cysylltiedig ar hyn o bryd mewn fformat hygyrch i'w cyhoeddi ar y we gyda'r testun hwn, fodd bynnag, gellir dod o hyd i ddelweddau a gwybodaeth ychwanegol ar dudalennau gwe'r cwmni.

The accompanying images are not currently in an accessible format for web publication with this text, however additional images and information can be found on the company webpages.

www.spiderplow.com

5) Tennet

Cyrhaeddodd yr ymateb a ddarparwyd gan Tennet ar ôl i ddrafftio'r adroddiad ddechrau ac felly ni chafodd ei ystyried yn fanwl gan y Grŵp Cynghori Annibynnol.

The response provided by Tennet arrived after drafting of the report started and were therefore not considered in detail by the Independent Advisory Group.

Mae'r sylwadau yn rhannu profiad technegol personol Uwch Gyngorydd ar Geblau a Llinellau yn Tennet, gweithredwr Rhwydwaith Trawsyrru yn yr Almaen. Nid yw'r sylwadau o reidwydd yn bolisi ffurfiol Tennet, nac yn farn y cwmni ar unrhyw ddatblygiadau nad ydyn nhw'n meddu arnyn nhw.

The comments are a sharing of the personal technical experience of a Senior Advisor on Cables and Lines at Tennet, a Transmission network operator in Germany. The comments are not necessarily Tennet's formal policy, or the company's views on any developments that are not their own.

Mae'r sylwadau'n cefnogi'r papur gan ATP Cable Plough, gan gyd-fynd ag adborth gan y cwmnïau eraill . Cynigiodd gyflwyno dealltwriaeth fanylach mewn cyfweliad, fodd bynnag, nid oedd y Grŵp yn ystyried tystiolaeth newydd ar yr adeg honno.

The remarks are supportive of the paper from ATP Cable Plough, aligning with feedback from the other companies above. He offered to provide a more detailed insight in interview, however the Group was not considering new evidence at this point.